

# METAL EARTH™

## 3D LASER CUT MODELS

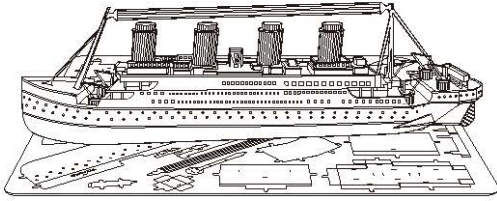

It is highly recommended that you visit [www.fascinations.com/meteearth360/mms030](http://www.fascinations.com/meteearth360/mms030) to see the completed model before assembling your own. Vor dem Zusammenbau Ihres Modells besuchen sie bitte <http://www.fascinations.com/meteearth/gallery360> für die Ansicht des aufgebauten Modells.



mms030

### To create the best connections Beste Verbindungen

- Insert tab and bend 90 degrees for most visible areas**  
Laschen einfügen und 90° umbiegen (bei den meisten sichtbaren Flächen).
- Insert tab and twist 90 degrees is best in some areas to ensure a tight connection**  
Laschen einfügen und um 90° verdrehen (in einigen Bereichen für eine straffe Verbindung sinnvoll).

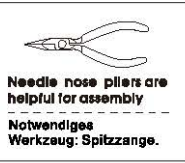

Needle nose pliers are helpful for assembly.  
Notwendiges Werkzeug: Spitzzange.

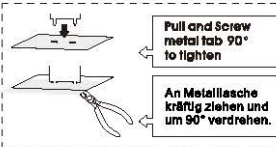
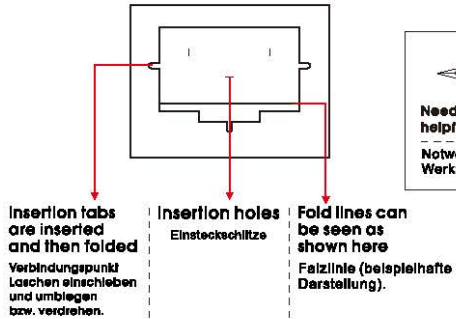

### Metal sheets Metallbogen

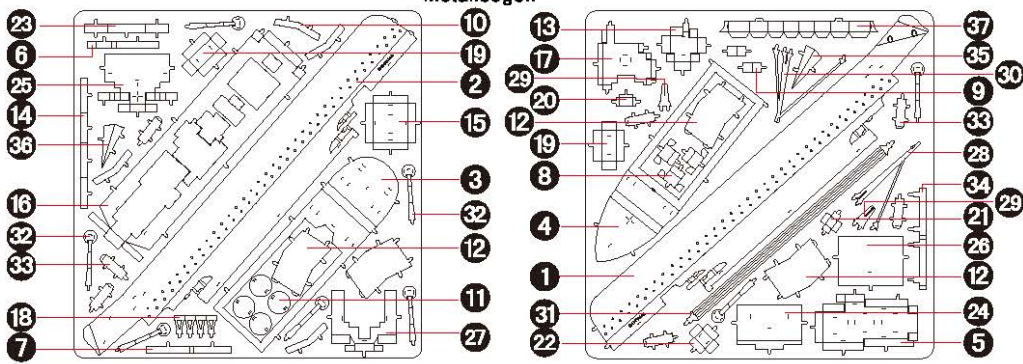

**In order to avoid possible injury from sharp edges, please carefully discard the metal sheet after parts have been removed.**  
Nach dem Herauslösen aller Bauteile den Rest des Metallbogens sicher entsorgen, um Verletzungen an scharfen Kanten zu vermeiden.

This product is not a toy. Keep out of reach of children.  
Sammelmodell - kein Kinderspielzeug. Von Kindern unter 14 Jahren fernhalten. Alter: 14+

### Assembly Flow Chart Ablaufschema für den Aufbau des Modells

