

WOODEN CITY®

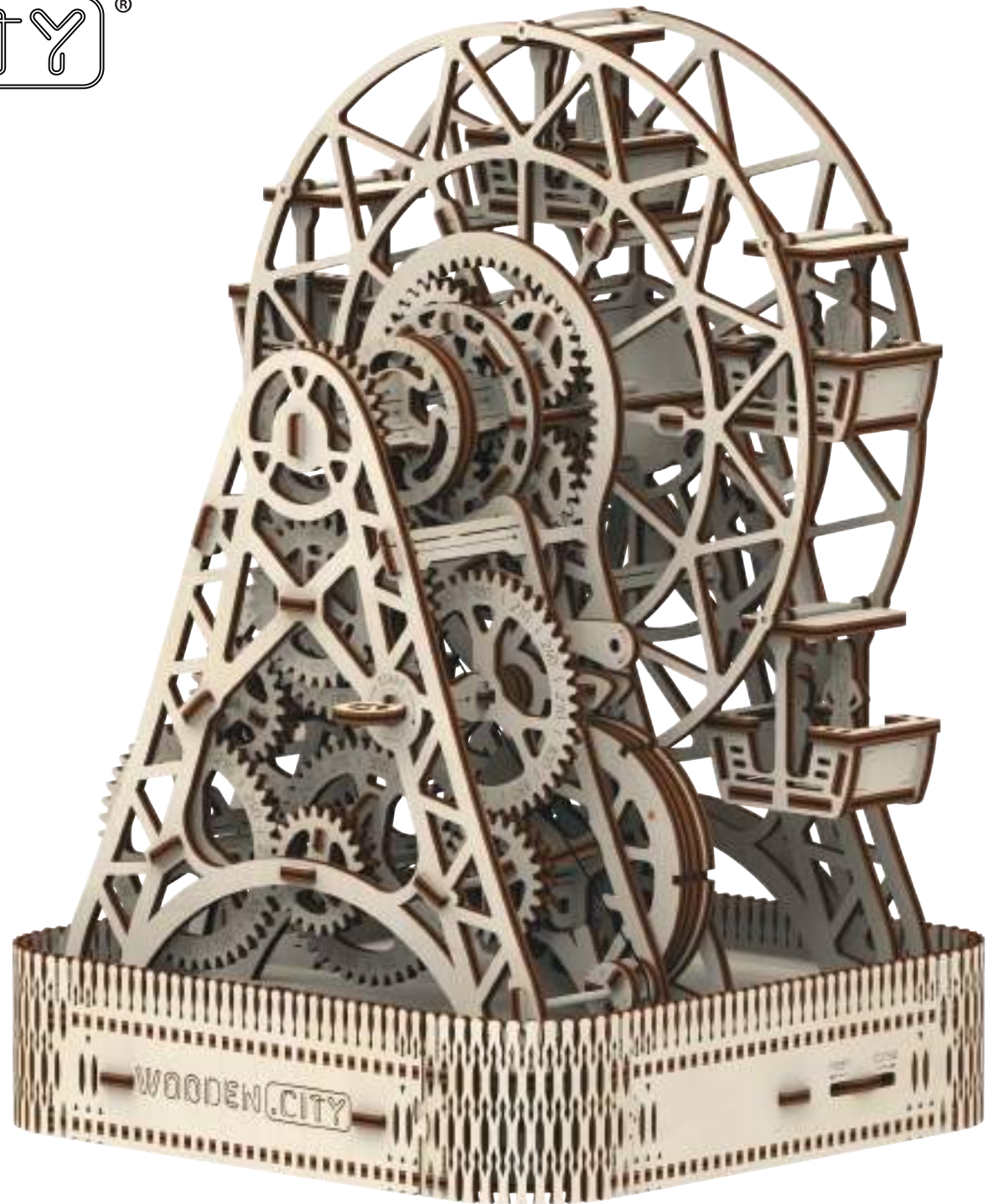

Ferris wheel
Assembly instruction

**EN**

Assembly instruction.

Package contains:

1. 430 parts on 11 ply sheets
2. 39 spare parts
3. Rubber bands
4. Axles (large and small)
5. Ruler (for checking dimensions)
6. Thread

You will need: razor blade, scissors, sandpaper and wax candle. Very carefully push out the pieces from the front side of the board, taking care not to break them. If the piece does not come out, gently cut the notches with the razor blade. This model does not require glue or paint. To reduce friction, the gear face and the axle rotation areas should be waxed. Assemble in a well-lit area, and follow the instructions carefully. You can also disassemble this model in reverse order.

**ES**

Instrucción de montaje.

El paquete contiene:

1. 430 partes fijadas en las 11 hojas de la madera contrachapada
2. 39 piezas de repuesto
3. Gomas elásticas
4. Ejes (grandes y pequeños)
5. Regla para comprobar las dimensiones
6. Hilo

Para el montaje necesitará: cuchillo de papelería, tijeras, papel de lija y una vela. Con mucho cuidado exprimirá los detalles desde el anverso de la tabla, tratando de no romperlos. Si, el detalle no sale, corte suavemente los puentes con el cuchillo estacionario. Este modelo se monta sin pegamento y no requiere la pintura. Para evitar el agarrotamiento y para reducir la fricción, la cara del engranaje y las áreas de rotación del eje deben encerarse. Es recomendable montar el modelo con buena iluminación y seguir estrictamente las instrucciones. También puede desmontar este modelo en orden inverso.

**FR**

Instruction de montage.

Composant modèle:

1. 430 pièces sur 11 panneau
2. 39 pièces de rechange
3. Des élastiques
4. Axe épais et mince
5. Il possède une règle pour vérifier les dimensions
6. Fil

Pour l'assemblage, vous auriez besoin: du couteau de papeterie, des ciseaux, du papier de verre et d'une bougie de cire. Il faut enlever les détails tout doucement du côté avant de la feuille, de soi, de façon qu'ils ne soient pas endommagés. Si l'article ne peut pas être retiré, coupez-le avec le couteau de papeterie. Le montage du modèle se fait sans colle et ne nécessite pas de peinture. Pour éviter les blocages et pour une meilleur glissement du mécanisme, il faut graisser les extrémités des engrenages et l'axe dans les zones de rotation avec la bougie de cire. Il est recommandé de monter le modèle ayant une bonne illumination et strictement selon les instructions. Vous pouvez également démonter ce modèle dans l'ordre inverse.

**PL**

Instrukcja składania

Zestaw zawiera:

1. 430 detali umieszczonych na 11 arkuszach sklejki
2. 39 części zapasowych
3. Gumki
4. Osie grube i cienkie
5. Linijka do sprawdzania wymiarów
6. Nić

Do złożenia modelu niezbędne będą: nóż techniczny, nożyczki, papier ścierny oraz świeca woskowa. Detale wypycha się delikatnie od prawej strony arkusza uważając, aby ich nie uszkodzić. Jeżeli wystąpi trudność z wyciśnięciem pożądanego elementu, wówczas należy go delikatnie naciąć nożykiem z lewej strony arkusza. Powinno się wypychać z arkusza tylko te elementy nad którymi aktualnie się pracuje, w przeciwnym razie mogą się pogubić. Model należy składać przy dobrze doświetlonym stanowisku zgodnie z instrukcją. Model można rozłożyć w odwrotnej kolejności. Model składa się bez użycia kleju. W celu prawidłowego funkcjonowania mechanizmu, należy osie i koła zębate natrzeć świecą woskową.

**DE**

Aufbauanleitung.
Im Set enthalten:

1. 430 Teile in 11 Platten
2. 39 Ersatzteile
3. Gummibänder
4. Achsen dick und dünn
5. Lineal zur Kontrolle
6. Faden

Fürs Zusammenbauen benötigen Sie: Messer, Schere, Schleifpapier und eine Kerze. Die Einzelteile werden von der Oberseite nach unten ausgedrückt. Wenn sich ein Teil nicht herausnehmen lässt, schneiden Sie die Haltestege mit dem Messer leicht ein Um ein Steckenbleiben vorzubeugen, schmieren Sie die Achsen und Zahnräder etwas mit dem Kerzenwachs ein. Dieses Modell ist ohne Kleber montiert und erfordert keine Lackierung. Sie beim Zusammenbau für eine gute Beleuchtung und setzen die Einzelteile strickt nach der Anleitung zusammen. Modell kann auch wieder auseinanderggebaut werden.

**CN**

组装说明
包装包含：

1. 430个零件分布于11块桦木板。
2. 39个备件。
3. 橡皮筋（作为动力驱动）
4. 粗细轴
5. 测量尺（集成在取件器）
6. 线

您可能需要以下工具：美工刀、剪刀、砂纸、以及干蜡。从正面扣取零件，可以配合取件器小心扣取。如果零件一时间无法取出，通过透光找到接触点用取件器轻轻压出，或者借助刀片的尖角。模型依靠契合搭建，过程中无需用到胶水（零件折断除外）。齿轮边缘以及轴面需要上蜡润滑。请在充足照明的区域拼装并仔细遵照说明书指示操作。如需拆卸，请根据图示反向顺序操作。

**RU**

Инструкция по сборке.
Комплектация модели:

1. 430 деталей, расположенных на 11 листах фанеры
2. 39 запасных деталей
3. Резинки канцелярские
4. Оси толстые и тонкие
5. Линейка для проверки размеров
6. Нитка

Для сборки Вам понадобится: канцелярский нож, ножницы, наждачная бумага и восковая свеча. Выдавливать детали нужно аккуратно с лицевой стороны листа от себя, чтобы их не повредить. Если деталь не вынимается, надрежьте перемычки канцелярским ножом. Модель собирается без клея и не требует покраски. Для предотвращения заклинивания и наилучшего скольжения механизма, необходимо торец шестерни и оси в местах вращения смазать восковой свечой. Собирать модель рекомендуется при хорошем освещении и строго по инструкции. Разбирать можно в обратной последовательности.

**IT**

Istruzioni di montaggio.
La scatola contiene:

1. 430 pezzi situati sui 11 fogli
2. 39 pezzi di ricambio
3. Gomme
4. Asse sottile e spessa
5. La linea e/o dima per controllare le dimensioni
6. Filo

Il necessario per costruire: coltello di cancelleria, forbici, carta vetrata e cera di candela. Premere delicatamente sui pezzi pretagliati, dalla parte anteriore del foglio, per non rovinarli. Se il singolo pezzo non può essere rimosso, fate piccoli tagli con un taglierino da cancelleria. Il modello si monta senza colla e non ha bisogno di essere pitturato. Per evitare inceppamenti e migliorare lo scivolamento dei meccanismi, attrezzarsi di un prodotto lubrificante tipo cera di candela. Si consiglia di montare il modello con la luce adeguata e seguendo le istruzioni. Lo smontaggio dello stesso può avvenire con le dovute precauzioni. Smontare il modello possibile in ordine inverso.

EN Notations **FR** Désignation symbollique **ES** Notas
PL Oznaczenia umowne **DE** Symbolbezeichnung **RU** Условные обозначения
IT Simboli **CN** 符号示意



EN Approximate assembly time.
FR Temps d'assemblage estimé.
ES Tiempo estimado de construcción.
PL Przybliżony czas składnia.
DE Aufbauzeit.
RU Примерное время сборки.
IT Tempo di costruzione stimato.
CN 预估装配时间



EN Check orientation of each piece before connecting.
FR Vérifiez l'emplacement des éléments.
ES Comprobar la posición de los elementos.
PL Uwzględnić sprawdzić rozmieszczenie elementów.
DE Prüfen Sie die Positionen der Elemente.
RU Проверьте расположение элементов.
IT Controllare le posizioni degli elementi.
CN 连接前检查每个零件的方向



EN Check the measurements with the ruler.
FR Vérifiez les dimensions.
ES Comprobar los tamaños.
PL Sprawdzić rozmiar.
DE Prüfen Sie die Abmessungen.
RU Проверьте размеры.
IT Controllare le dimensioni.
CN 用尺测量



EN Press each piece all the way up to the stop.
FR Appuyez au maximum.
ES Presione hasta el tope.
PL Wciśnij do oporu.
DE Bis zum Anschlag zusammendrücken.
RU Прижмите до упора.
IT Premere per interrompere.
CN 推到位



EN Use wax.
FR Lubrifiez les pièces avec la bougie.
ES Cera los detalles.
PL Natrzyj element świecą woskową.
DE Mit Kerzenwachs einschmieren.
RU Смажьте детали свечой.
IT Candela per Lubrificare le parti.
CN 上蜡



EN Remember spare pieces are included.
FR Pièces de rechange.
ES Detalles de repuesto.
PL Części zamiennie.
DE Ersatzteile.
RU Запасные детали.
IT Pezzi di ricambio.
CN 备件库



EN Cut off with a knife.
FR Coupez avec le couteau.
ES Cortar con el cuchillo.
PL Odetniij nożem.
DE Abschneiden.
RU Отрежьте ножом.
IT Taglierino.
CN 去毛刺或用到切断

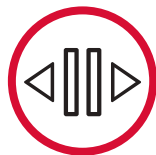

EN Carefully move apart.
FR Faites séparer délicatement.
ES Separar cuidadosamente.
PL Delikatnie rozsunąć detale.
DE Vorsichtig auseinanderschieben.
RU Аккуратно раздвиньте.
IT Far scorrere delicatamente.
CN 小心地移开



EN Use sandpaper or razor blade to smooth notches on each piece.
FR Les bavures après les coupures doivent être poncées légèrement avec du papier de verre fin ou coupées soigneusement avec un couteau de papeterie.
ES Las rebabas en el puente deben ser amoladas suavemente con el papel esmeril o cortadas cuidadosamente con el cuchillo estacionario.
PL Uwaga: pozostałości po złączeniach technicznych na detalach można usunąć drobnoziarnistym papierem ściernym lub nożem technicznym.
DE Eventuell verbleibende Haltereste mit Messer oder Schleifpapier entfernen. Das Modell wird ohne Kleber zusammengesetzt.
RU Заусенцы от перемычек следует отшлифовать легкими движениями мелкой наждачной бумагой или аккуратно срезать канцелярским ножом.
IT Le barbe dei ponticelli devono essere levigate leggermente con la sottile carta vetrata o tagliati con cautela con coltello di cancelleria.
CN 用砂纸或刀片去除零件上的毛刺使其光滑。

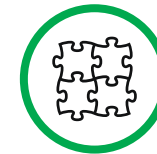

EN The part numbers that are included in this node.
FR Les références sont incluses dans cette unité.
ES Números de piezas que forman parte de la junta.
PL Numery części, które wchodzą do składu danego węzła.
DE Die Nummern der Elemente, die zu diesem Teil des Modells gehören.
RU Номера деталей которые входят в этот узел.
IT Numero di pezzi per questo nodo.
CN 组件包含多个零件。

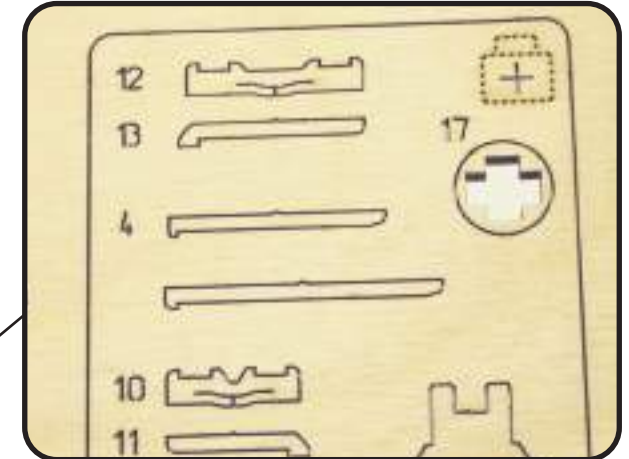
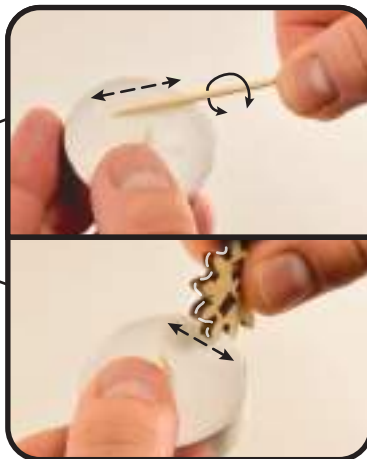
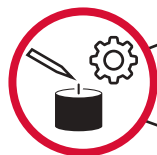

EN The ruler is used for size check. **FR** La règle pour vérifier les dimensions. **ES** La escala para la verificación de tamaño. **PL** Linijka do sprawdzenia wymiarów. **DE** Lineal um diverse Abmessungen zu prüfen. **RU** Линейка для проверки размеров. **IT** La linea per controllare le dimensioni. **CN** 取件器 (含测量尺) 用于尺寸检查。



EN These holes help to push thin axles through several of the pieces. **FR** Les ouvertures indiquées vous aideront à pousser l'axe fin à travers quelques détails. **ES** Estos agujeros ayudan a empujar el eje delgado a través de varios detalles sobre ejes. **PL** Otwory w linijce mogą być pomocne przy przeciskaniu patyczków (osi) przez kilka elementów. **DE** Die angegebenen Öffnungen helfen Ihnen, eine dünne Achse durch mehrere Öffnungen zu schieben. **RU** Указанные отверстия помогут протолкнуть тонкую ось через несколько деталей. **IT** Questi piccoli fori aiuteranno a spingere ed inserire l'asse attraverso le piccole parti. **CN** 小孔可以帮助您将细轴推入。

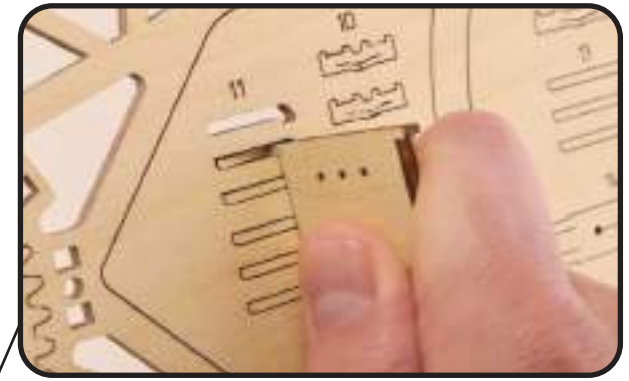

EN This tool is for pushing the small pieces out of the board. Also may be used for disassembly. **FR** La proéminence est conçue pour aider à presser et enlever les petits détails de la feuille. On peut l'utiliser aussi pour pousser les petites pièces lors du démontage du modèle. **ES** La repisa es para apretar los pequeños detalles fuera del tablero. Además, también puede empujar los pequeños detalles en el proceso de desmontaje. **PL** Występ w linijce przeznaczony jest do wyciskania małych detali z arkusza sklejk. Można go wykorzystać również przy rozkładaniu modelu. **DE** Der Vorsprung dient dazu, kleine Teile aus den Platten zu drücken. Er kann auch zum ausdrücken kleiner Teile beim Auseinanderbauen des Modells benutzt werden. **RU** Выступ предназначен для выдавливания из листа мелких деталей. Также им можно выталкивать мелкие детали при разборке модели. **IT** Le proiezioni riportate sui fogli di istruzioni sono utili anche nella fase di smontaggio per estrarre i pezzi. **CN** 此工具可以用于小零件的扣取，还可以在拆卸时用于零件顶出。(如插销等)

EN This tool is to help install the rubber bands. **FR** Cet article permet une installation facile de l'élastique. **ES** Este detalle es para la instalación fácil del caucho. **PL** Służy do łatwiejszego montażu gumki napędowej. **DE** Dieses Teil vereinfacht die Installation des Gummis. **RU** Эта деталь для удобной установки резинки. **IT** Questo dettaglio serve per il comodo montaggio dell'elastico. **CN** 此工具主要用于橡皮筋的安装，十分方便。

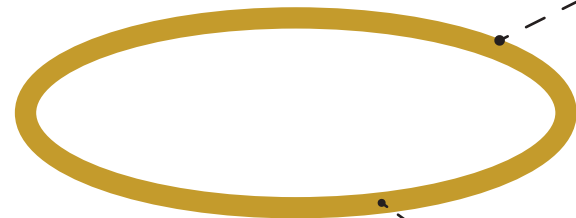

EN The yellow rubber band is for the rotation of the model mechanism. Install it as shown in the picture. **FR** L'élastique jaune est conçu pour faire tourner le mécanisme du modèle. Installez-le comme est indiqué sur le dessin. **ES** El caucho amarillo es para la rotación del mecanismo del modelo. Instálolo como se muestra en la imagen. **PL** Żółta gumka przeznaczona jest do napędu mechanizmu modelu. Zamontować ją należy zgodnie z instrukcją. **DE** Gelbes Gummiband dient dazu, den Mechanismus zu drehen. **RU** Желтая резинка предназначена для вращения механизма модели. Установите её как показано на рисунке. **IT** Elastico giallo serve per il movimento del meccanismo del modello. Installare come mostrato nel disegno. **CN** 黄色橡皮筋 (或者橘色) 为模型结构提供旋转动力。按照图示安装。

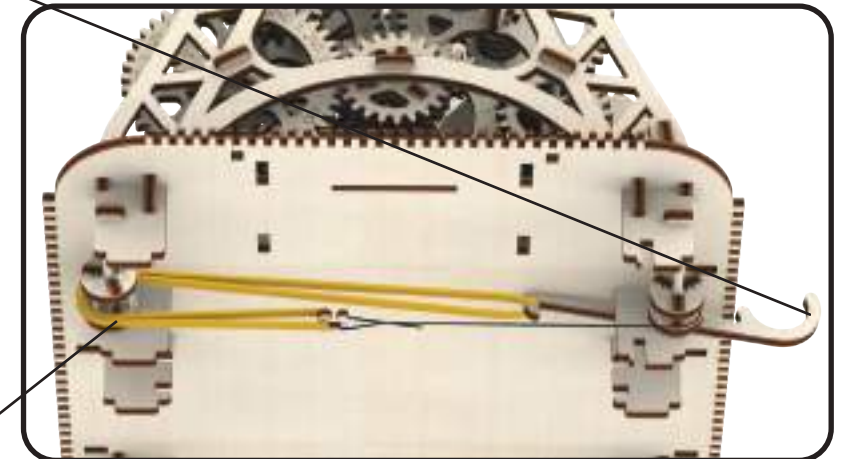

EN Axles large and small **FR** Axe épais et mince **ES** Ejes grandes y pequeños **PL** Osie grube i cienkie
DE Achsen in dick und dünn **RU** Оси толстые и тонкие **IT** Asse sottile e spessa **CN** 粗轴和细轴

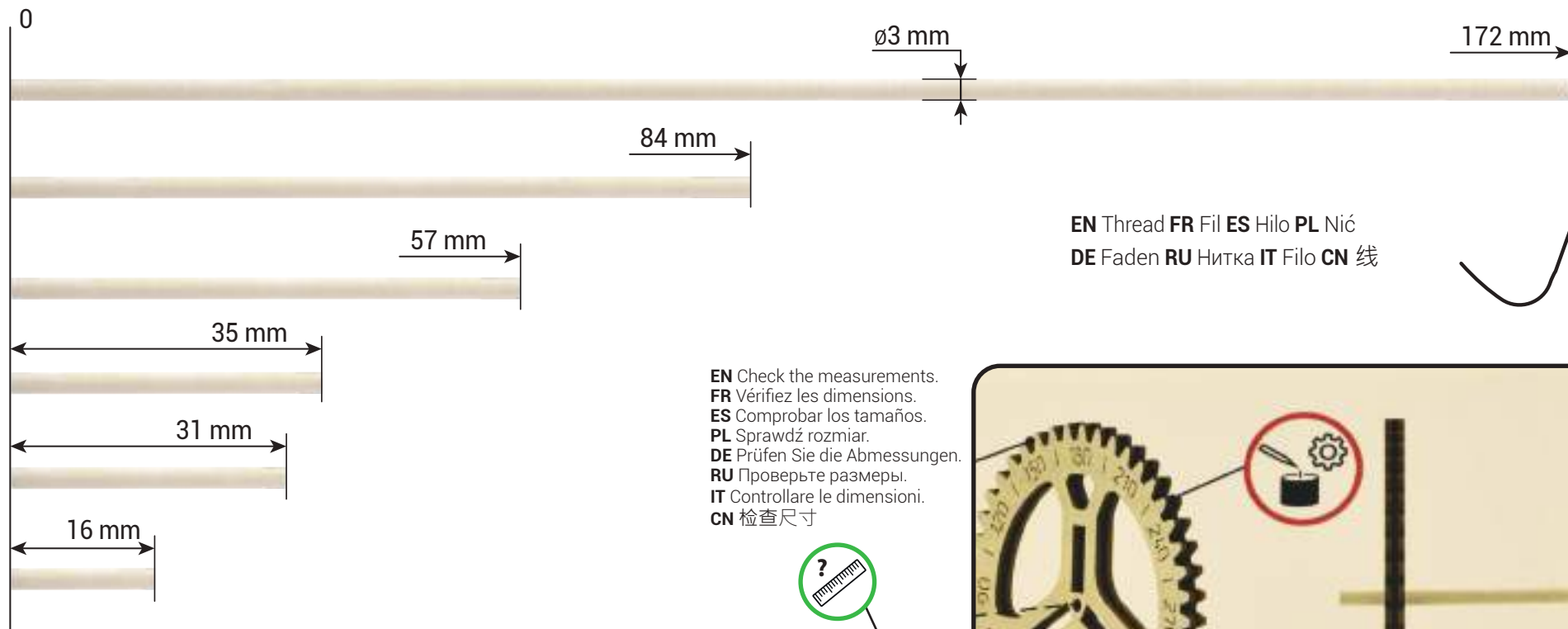

EN Thread **FR** Fil **ES** Hilo **PL** Nić
DE Faden **RU** Нитка **IT** Filo **CN** 线

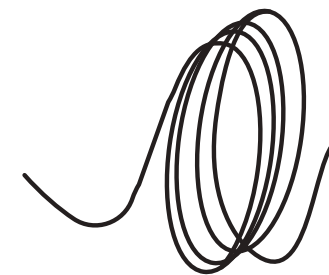

EN Check the measurements.
FR Vérifiez les dimensions.
ES Comprobar los tamaños.
PL Sprawdź rozmiar.
DE Prüfen Sie die Abmessungen.
RU Проверьте размеры.
IT Controllare le dimensioni.
CN 检查尺寸

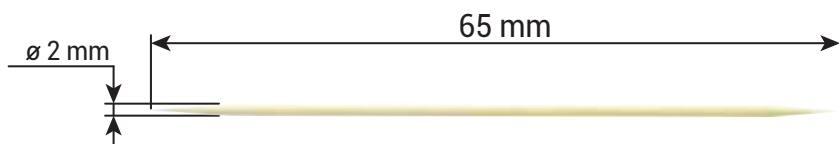
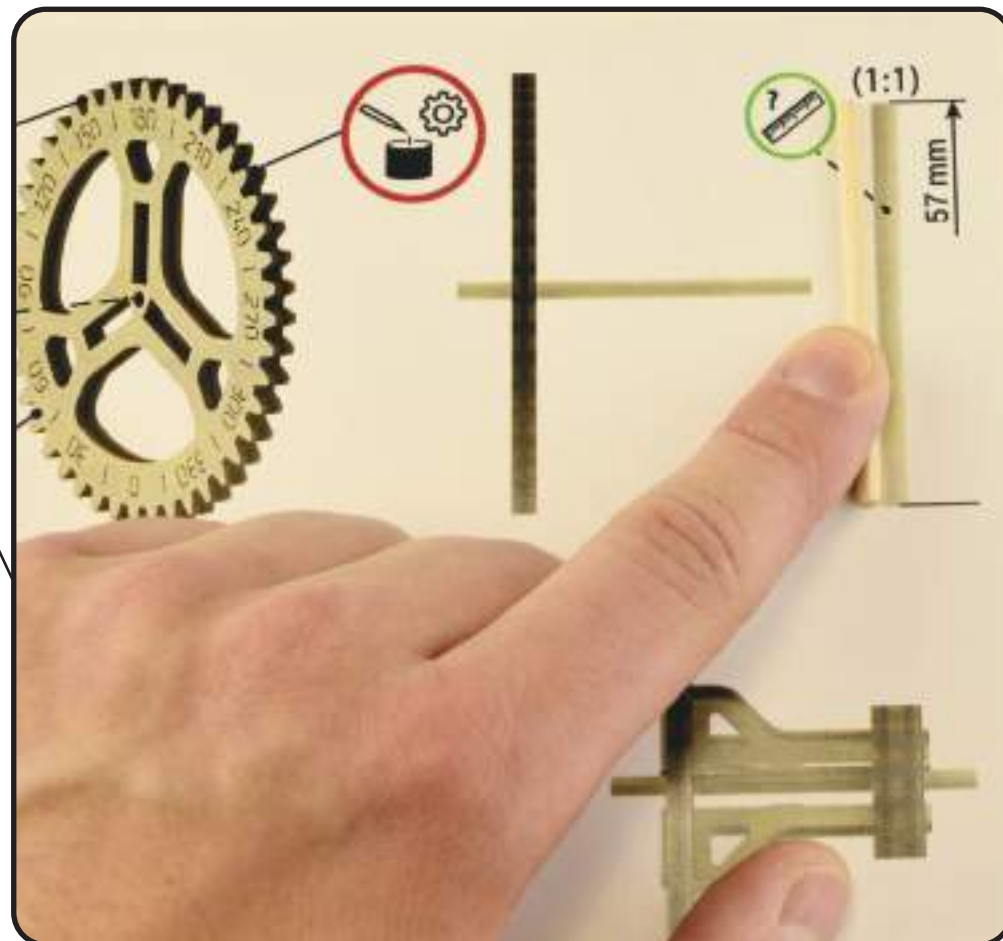

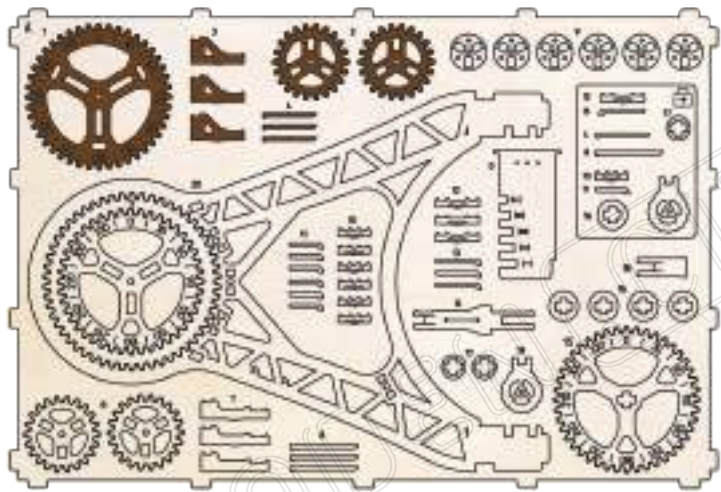

1

1

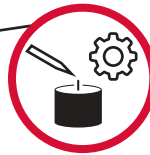

(1:1)

57 mm

57 mm

2



3

3

3



4



4

4

4

5



5

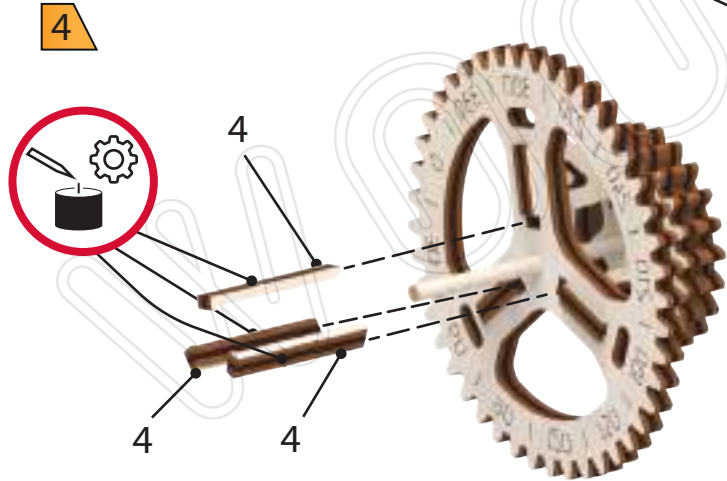
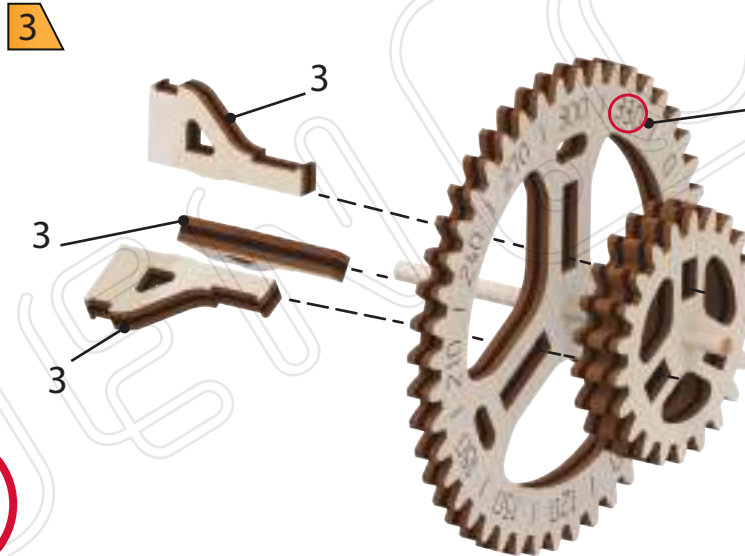
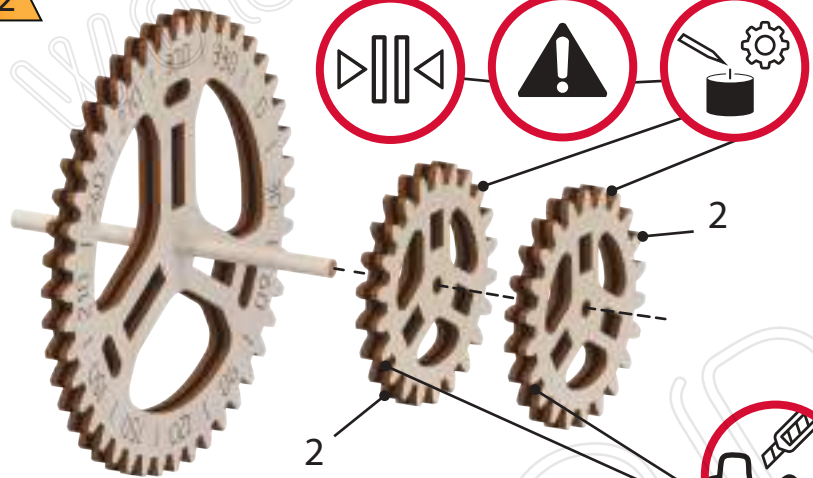

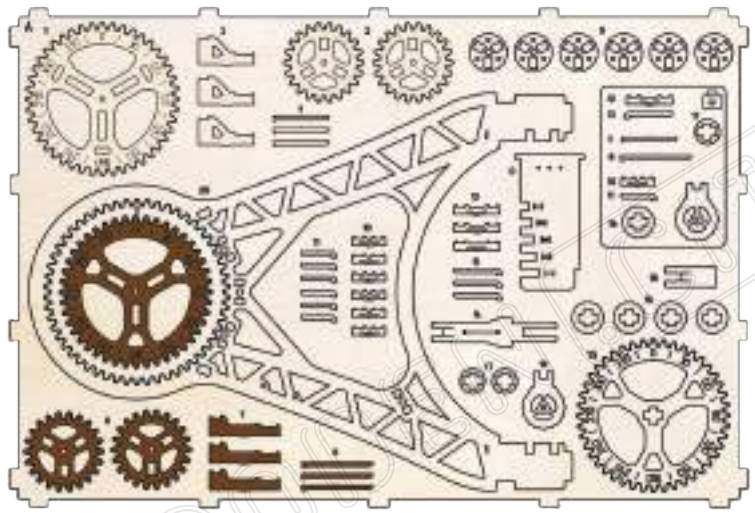

1

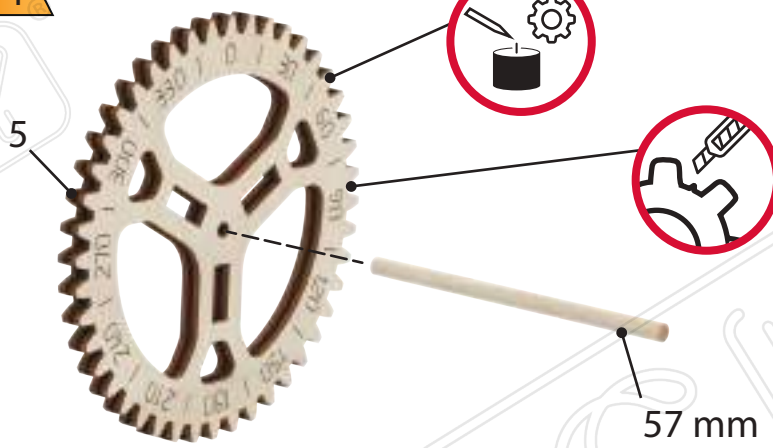

2

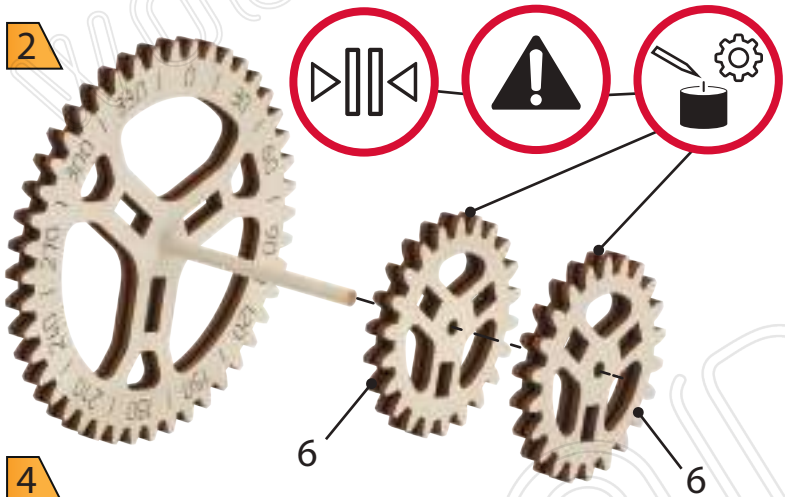

3

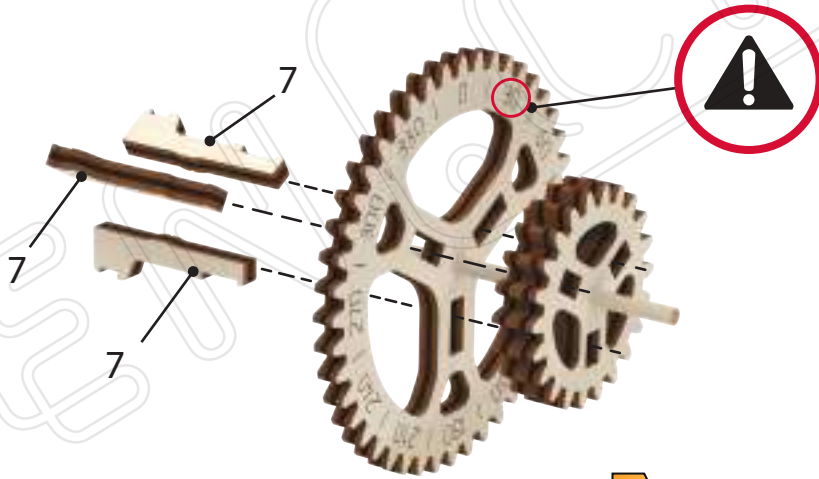

4

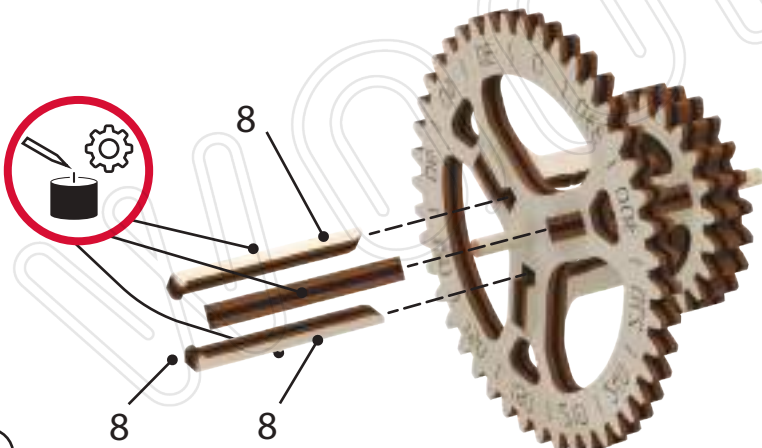

5

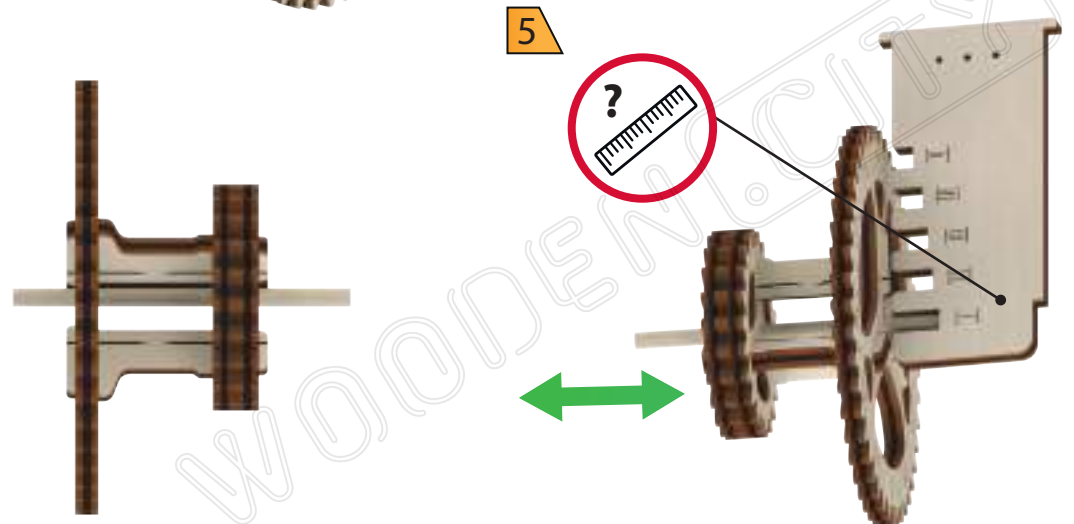

6

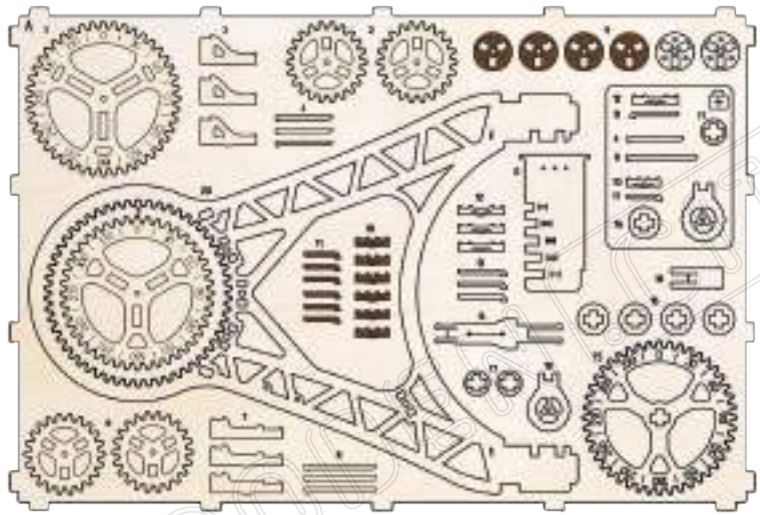

1

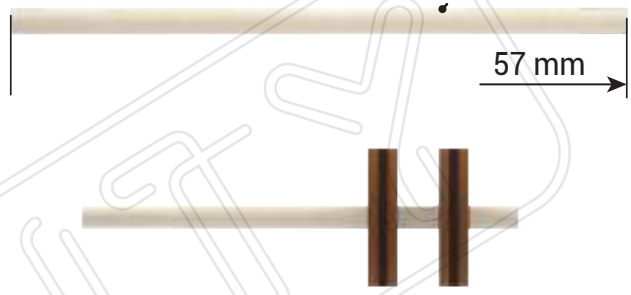
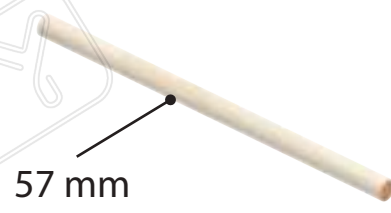

2

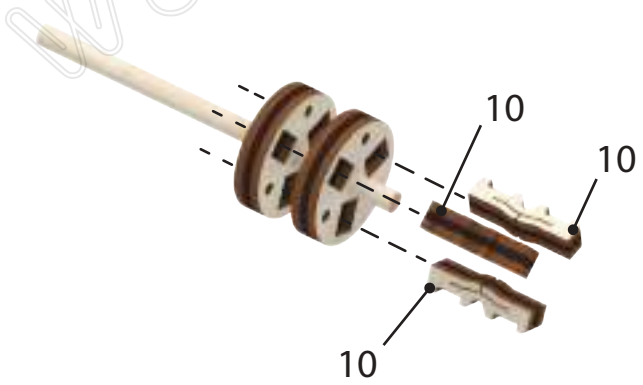

3

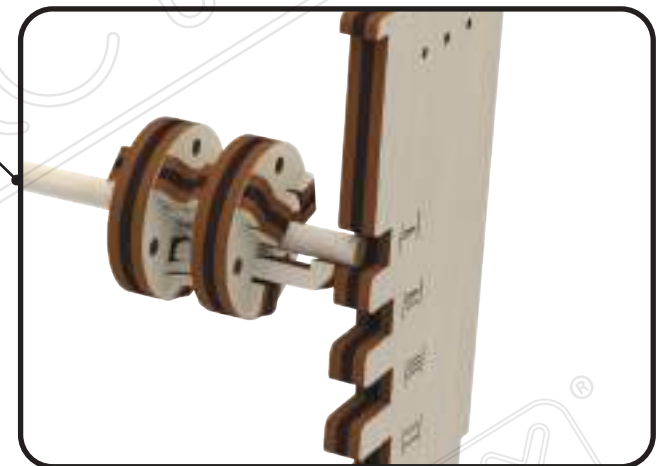
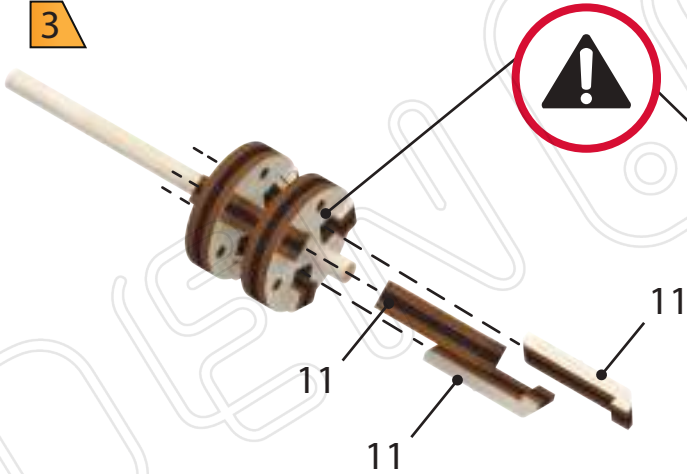

4

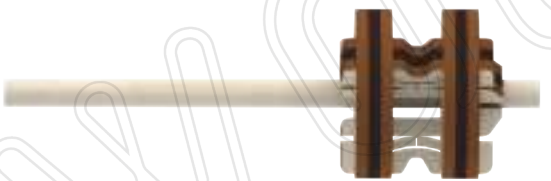

5

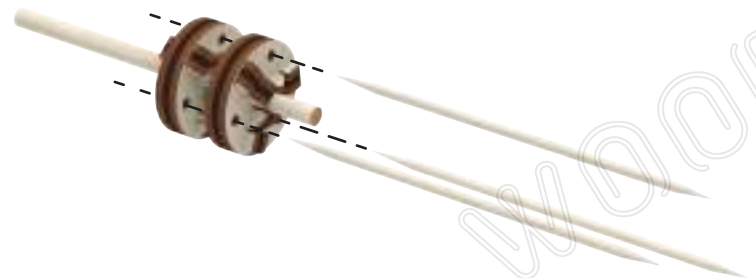

x3



7

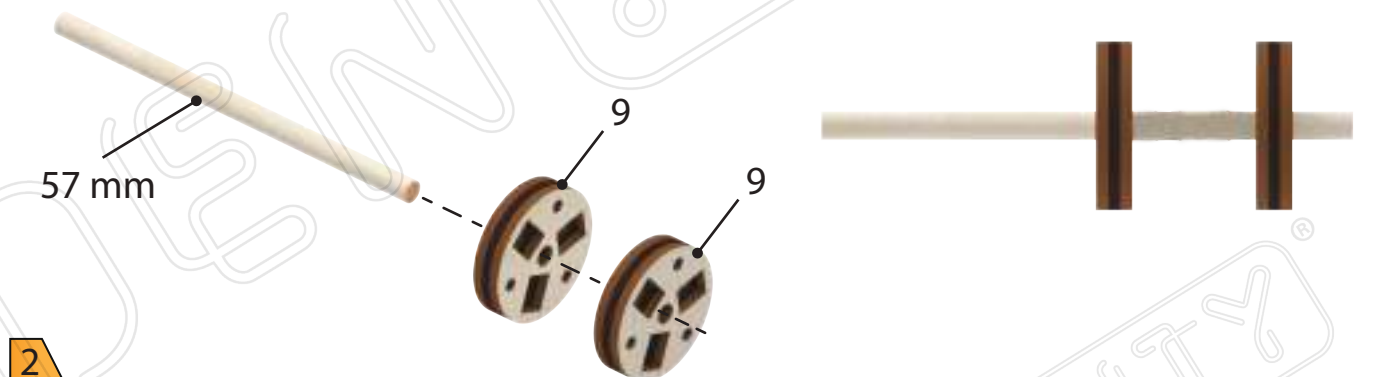
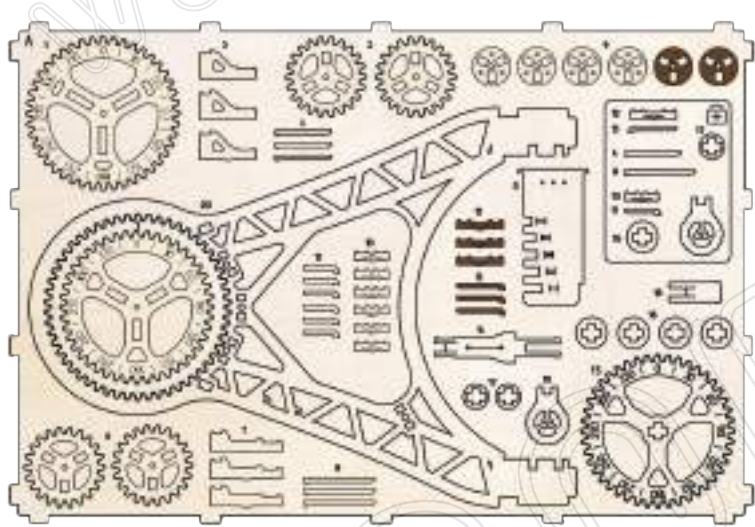
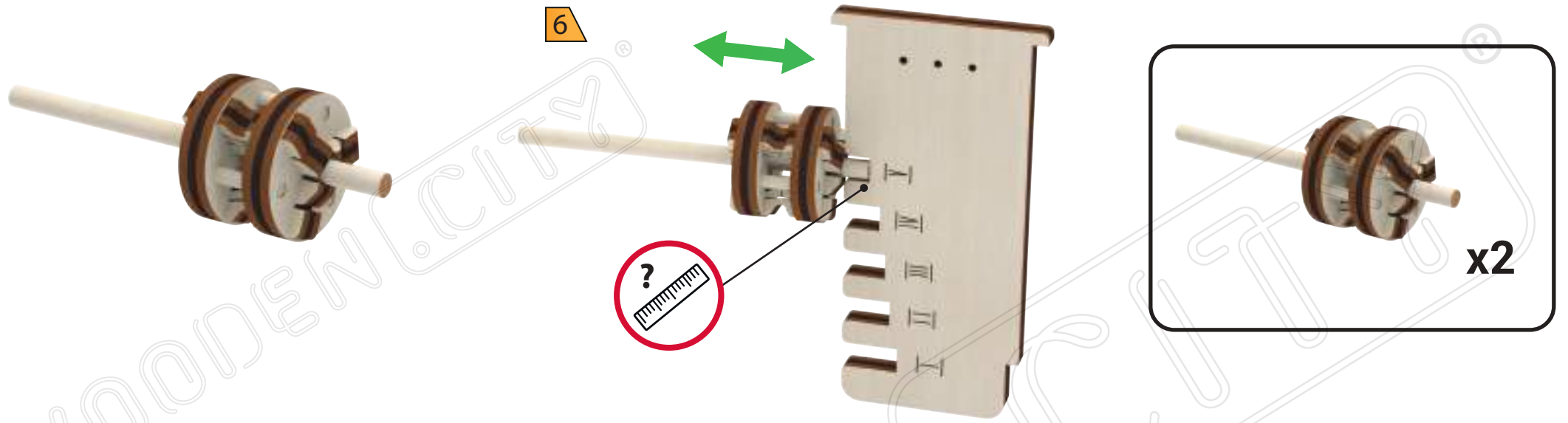

8

3

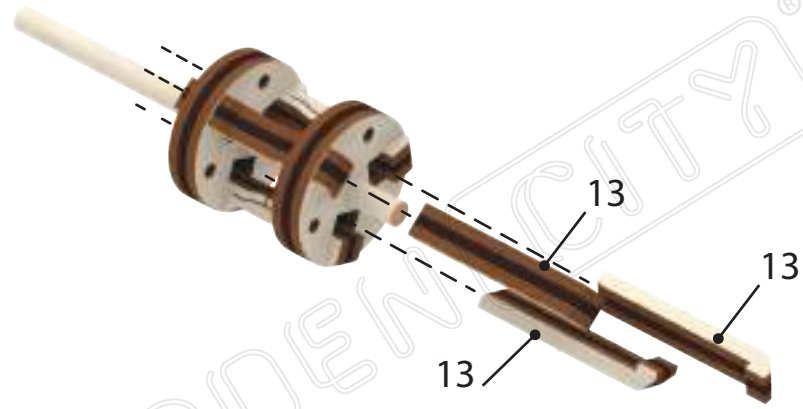

4

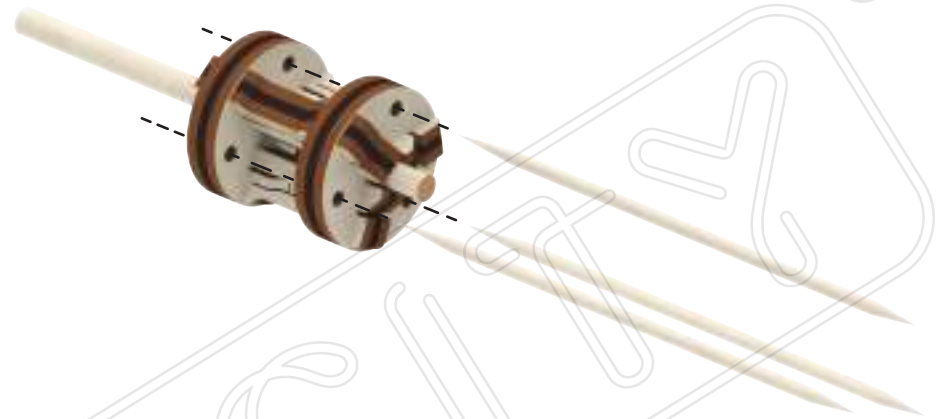

5

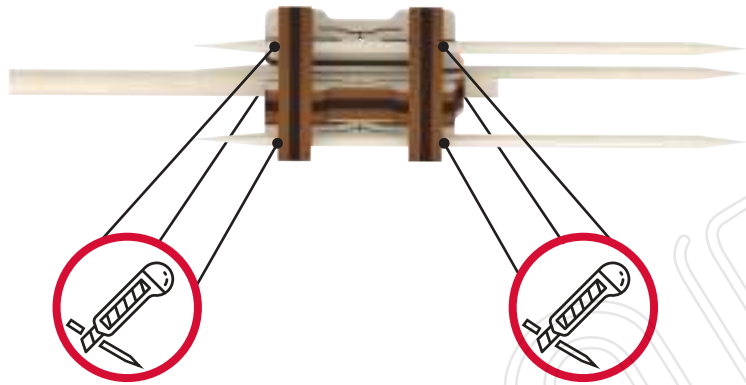

6

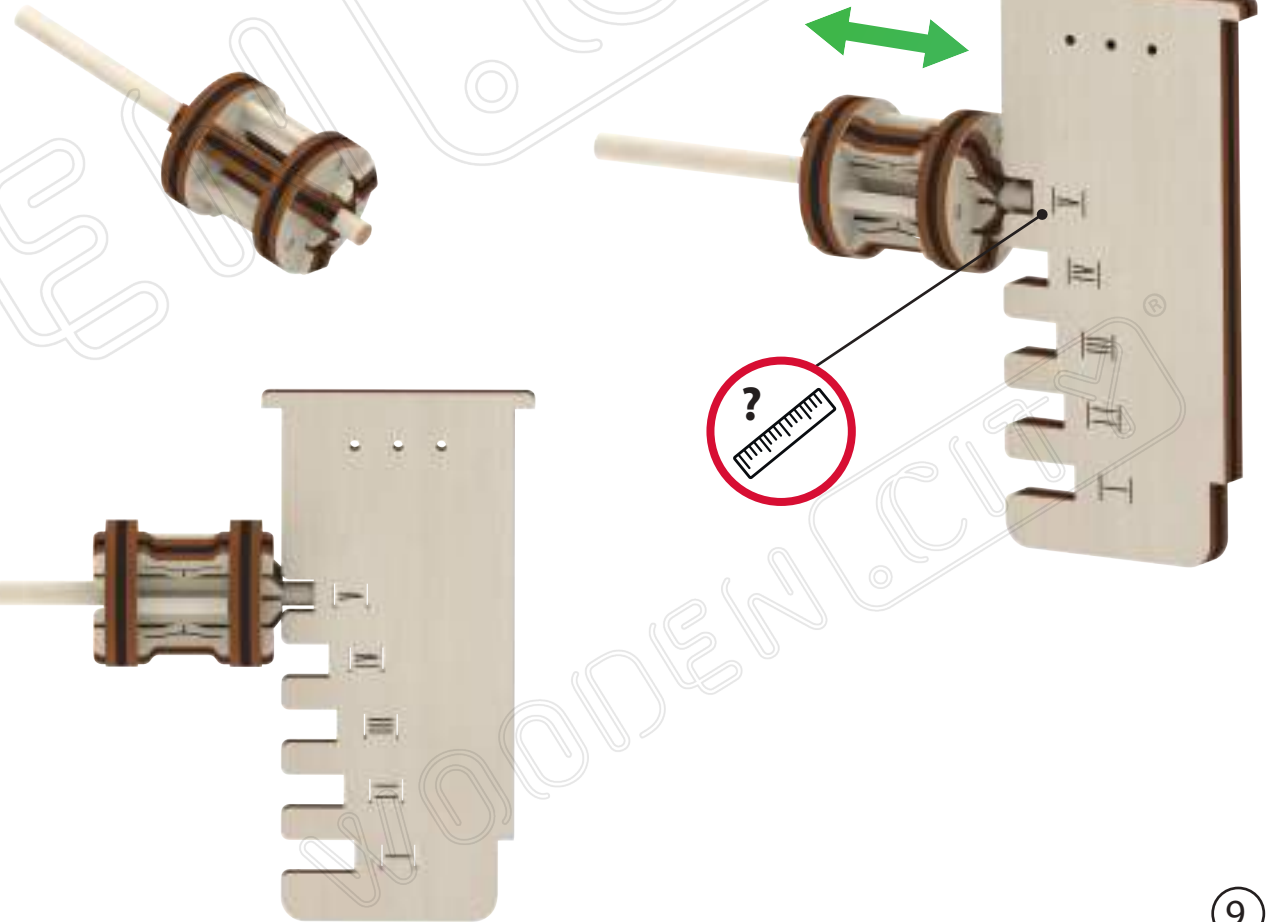

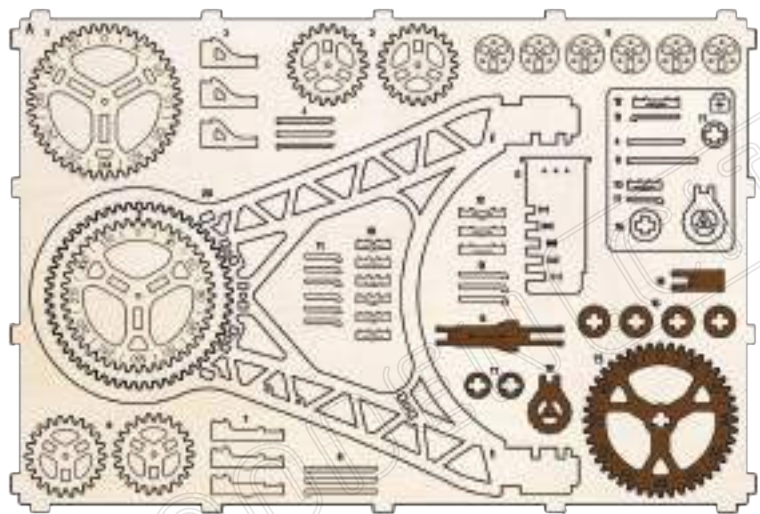

1

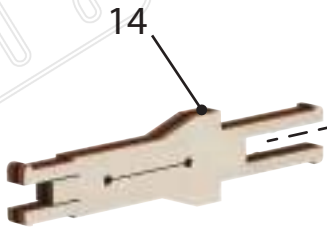

15

2

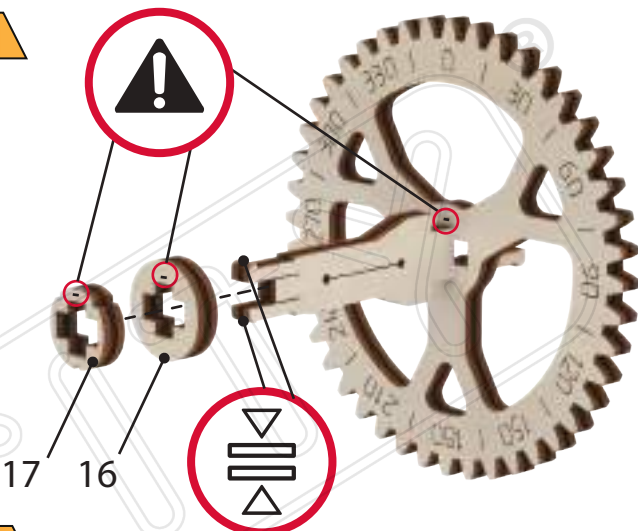

17

16

3

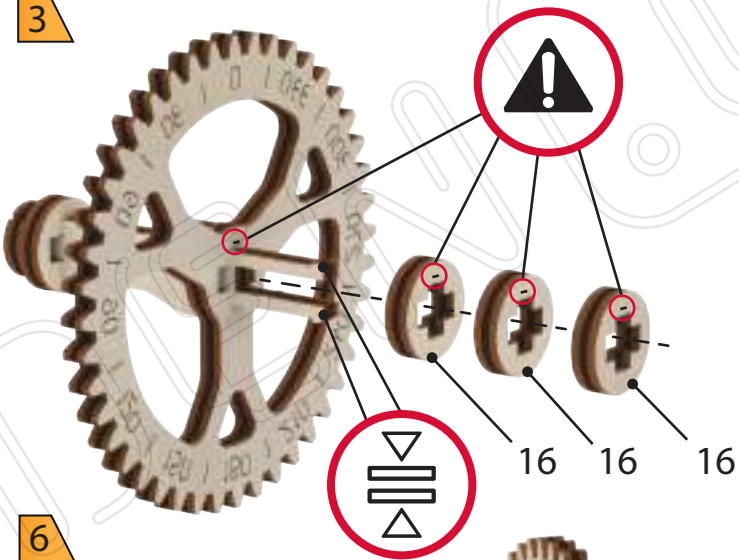

16

16

16

4

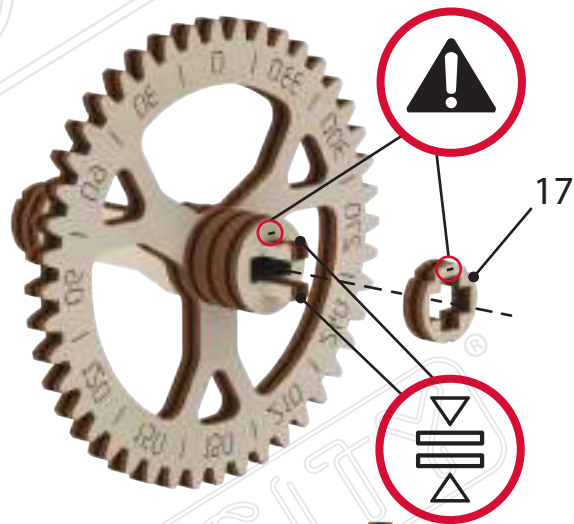

17

5

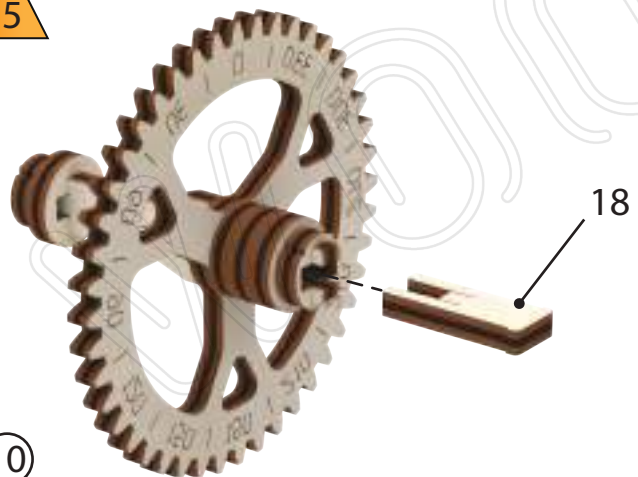

18

6



19

10

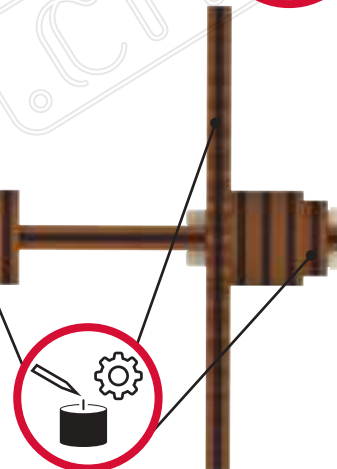

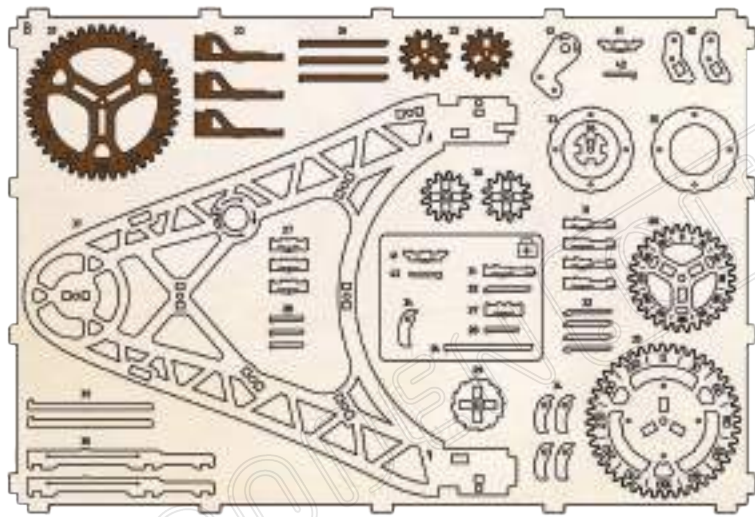

1

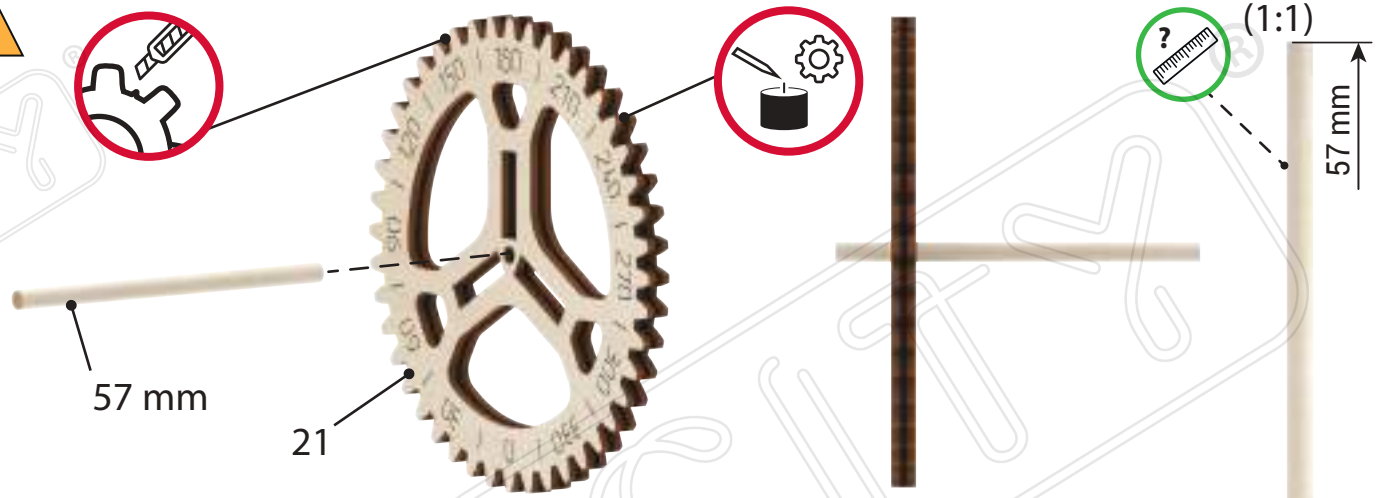

2

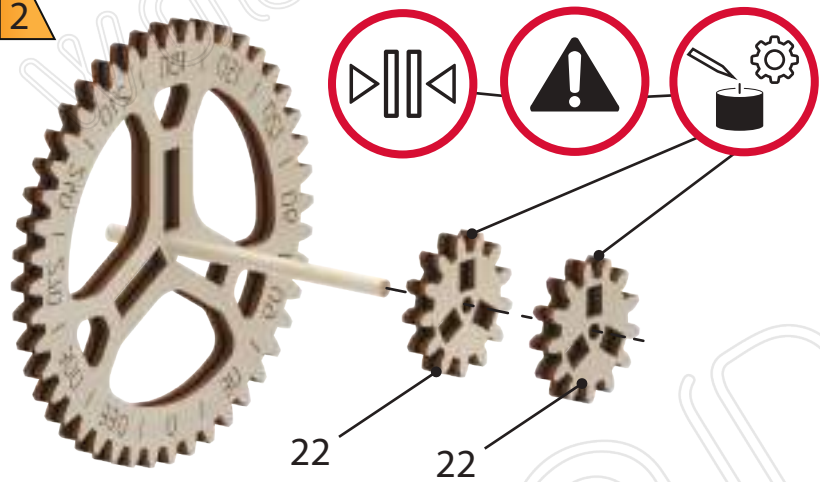

3

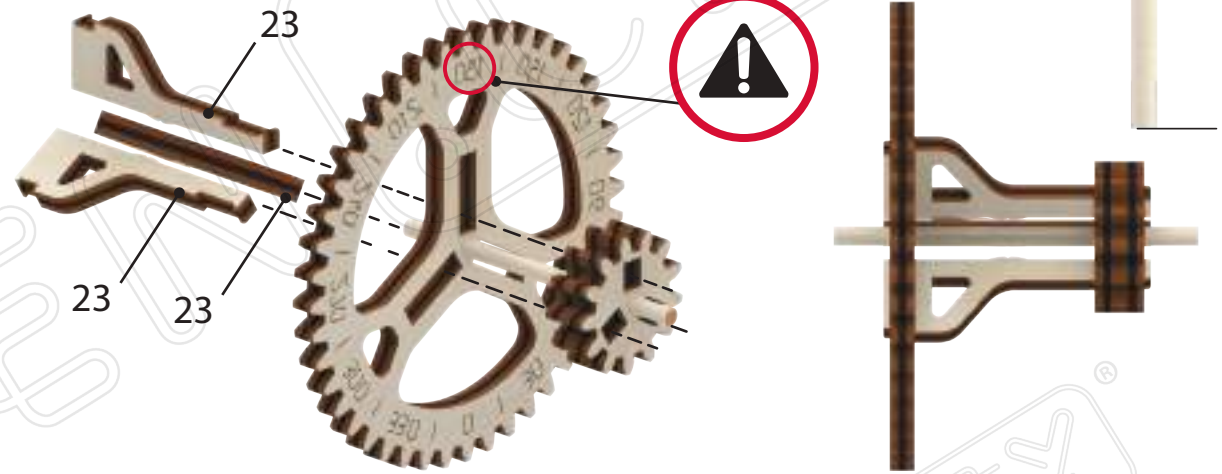

4

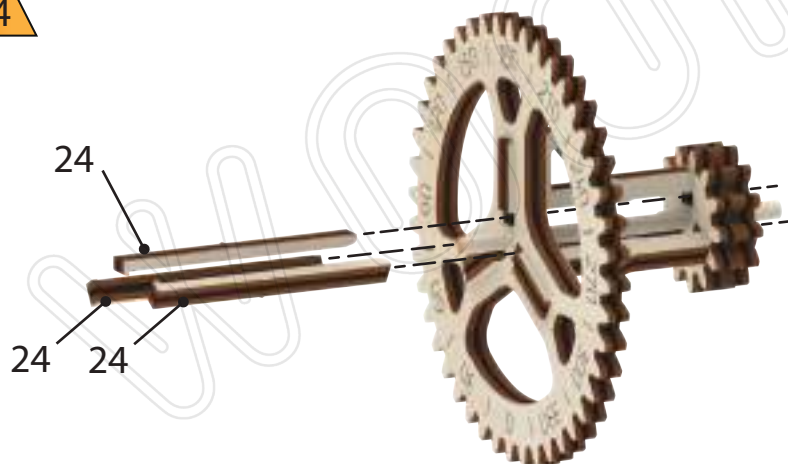

5

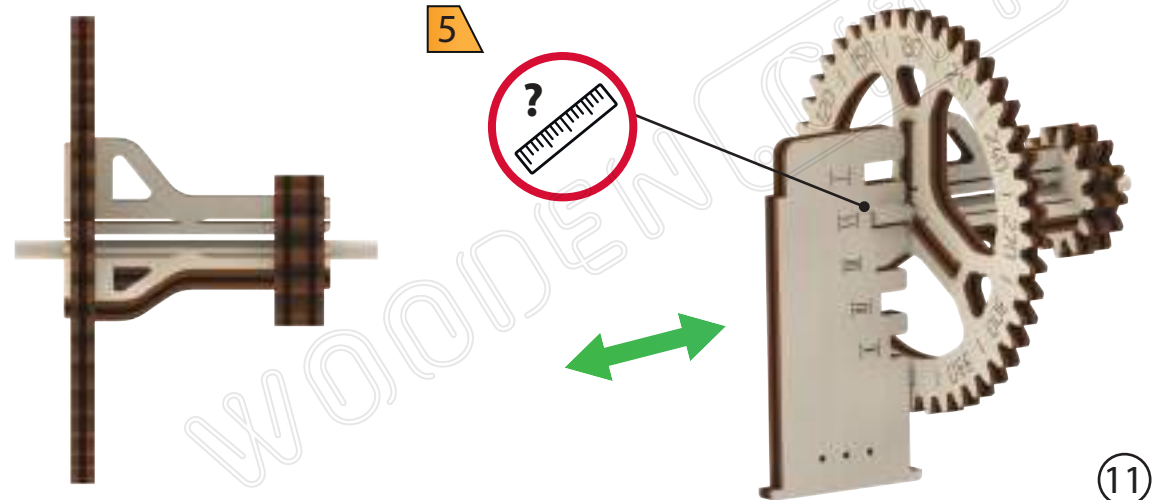

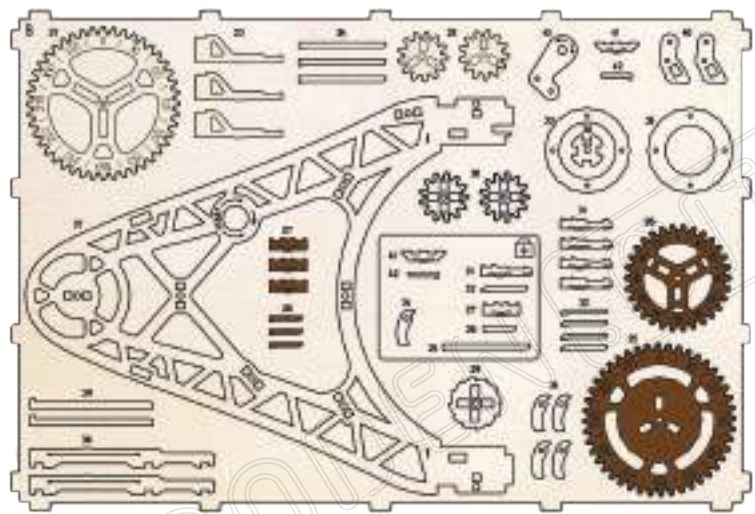

1

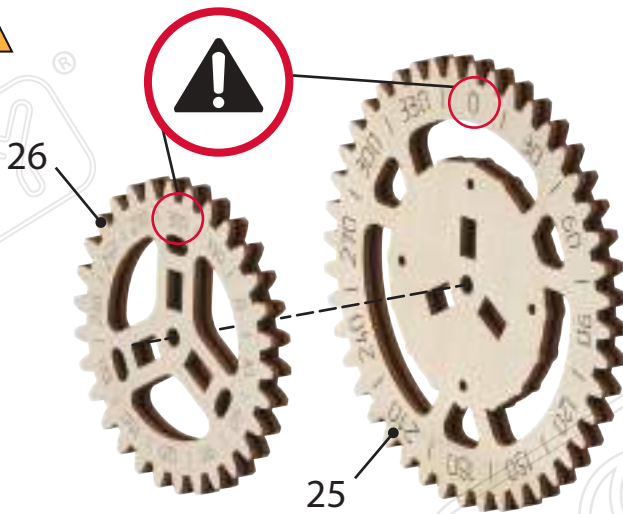

2

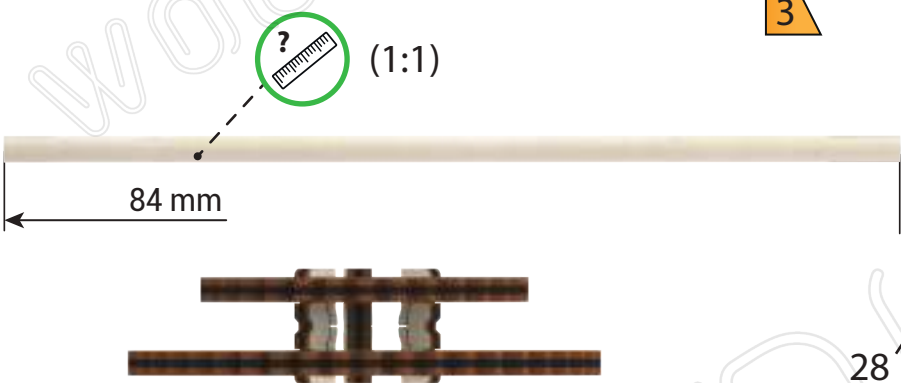
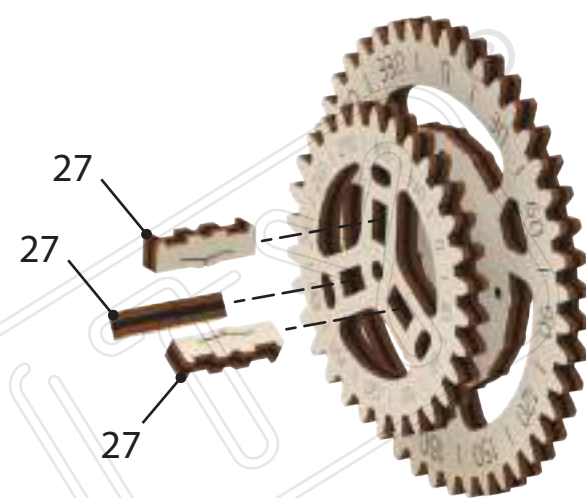

3

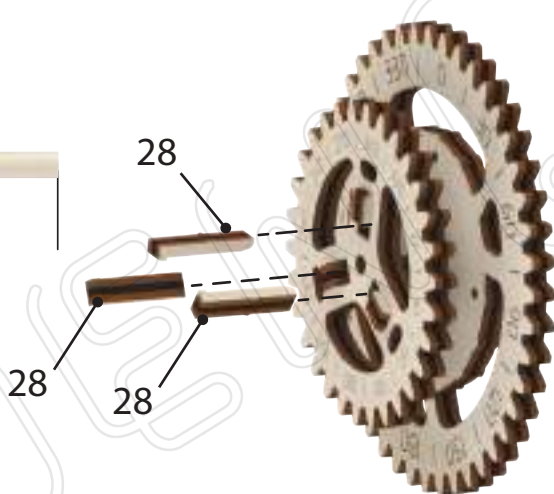

4

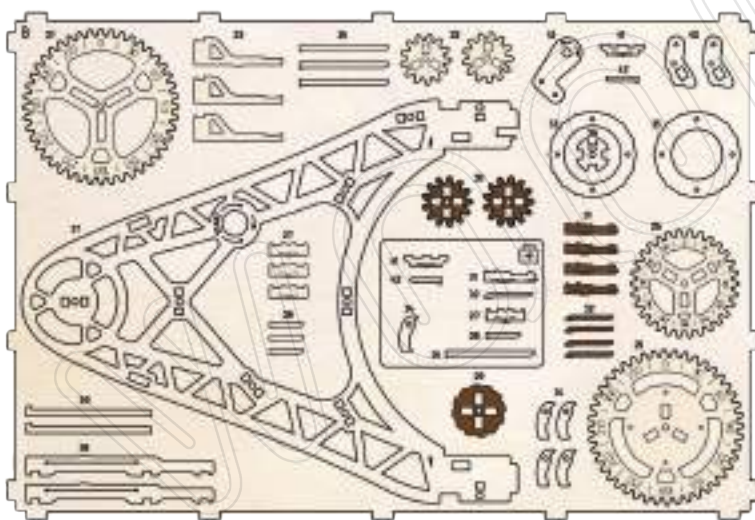
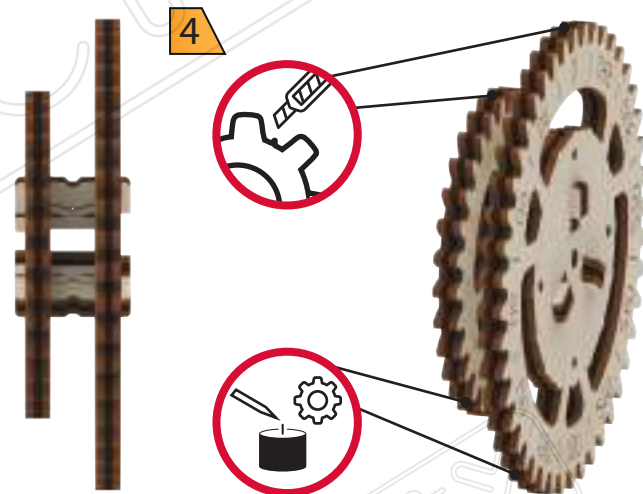

5

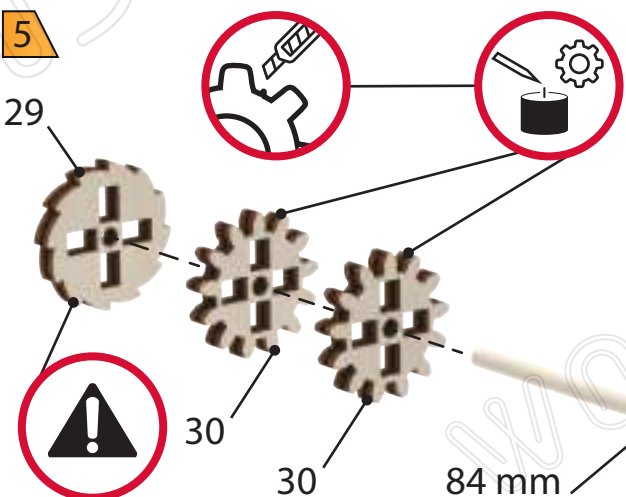

6



12

7

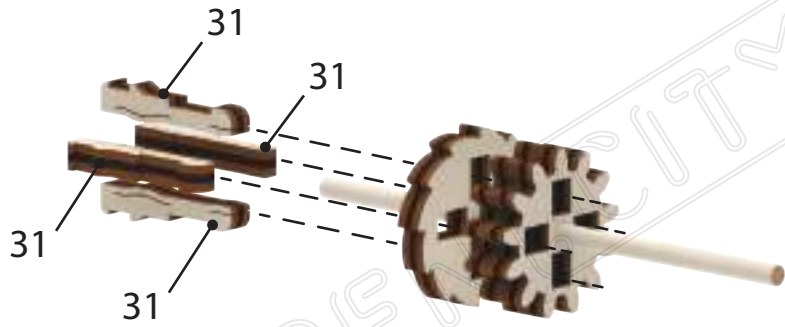

8

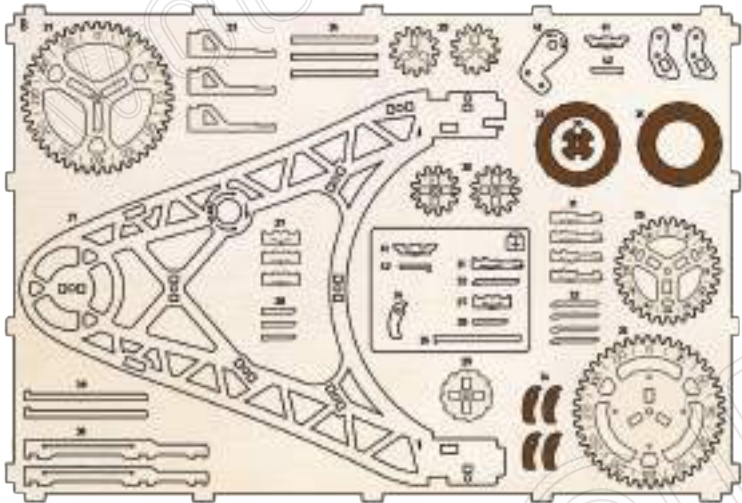
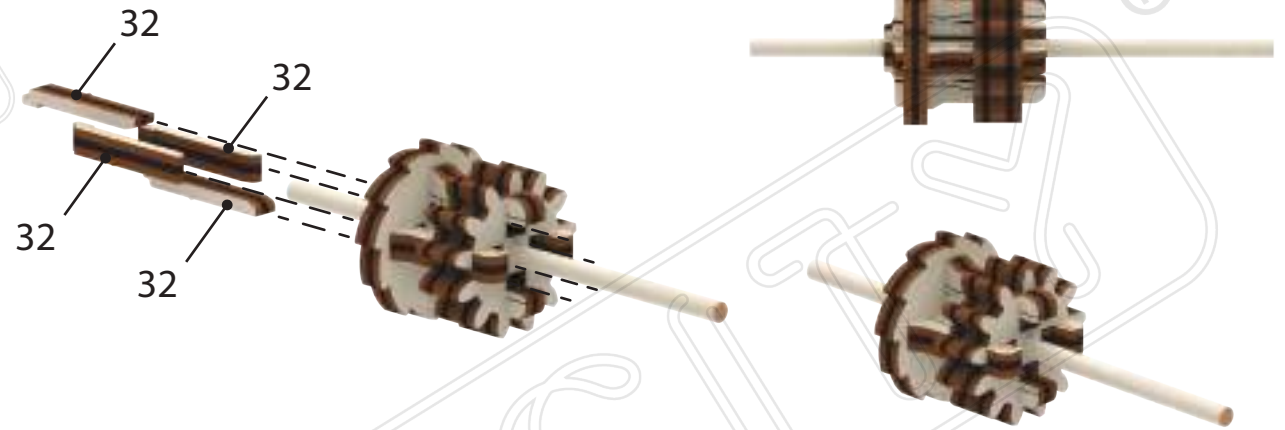

9

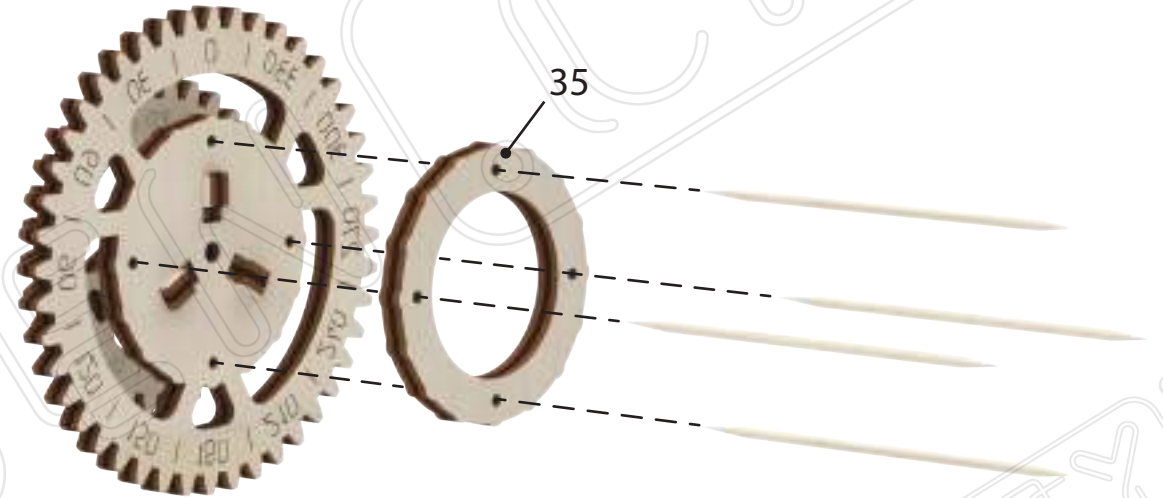

10

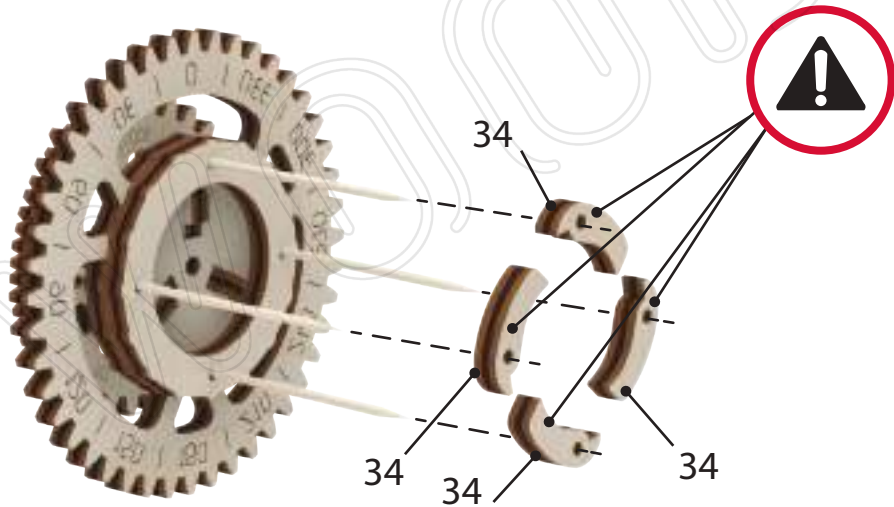

11

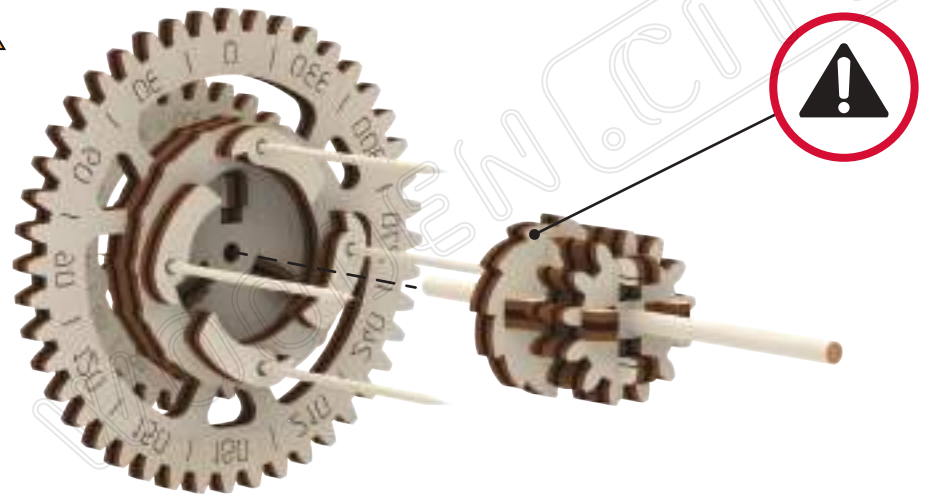

13

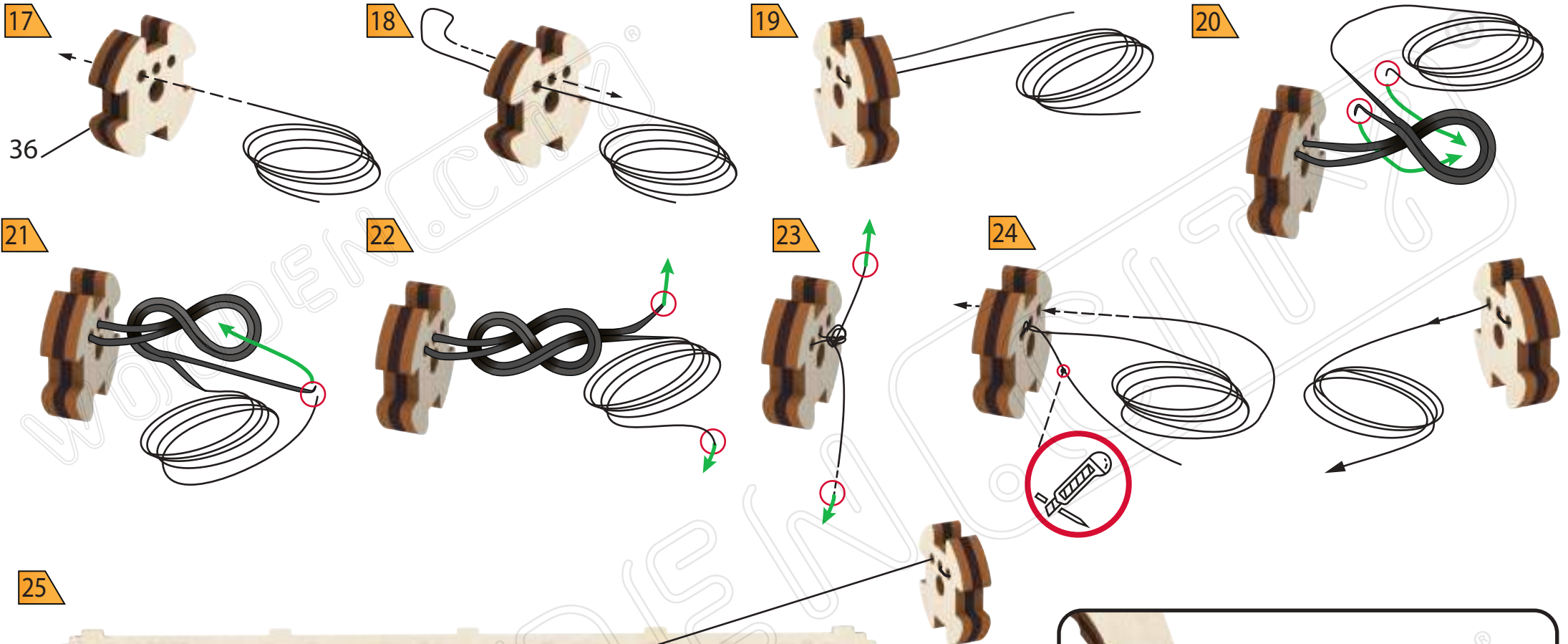

25

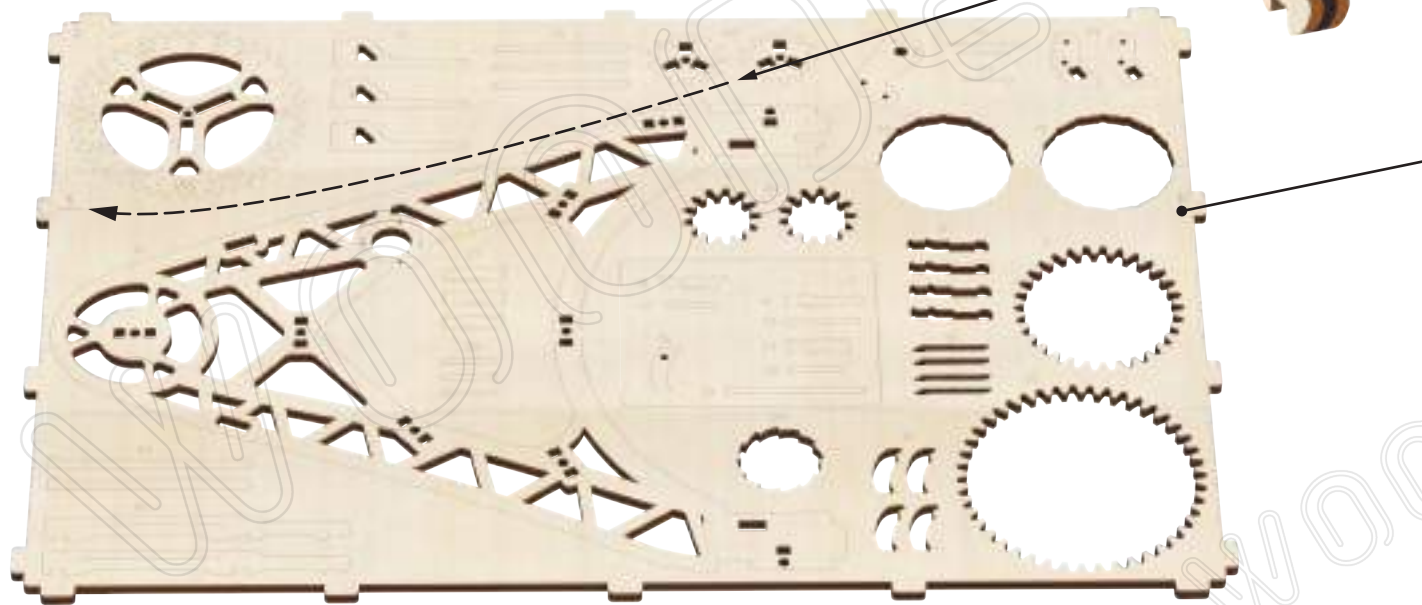

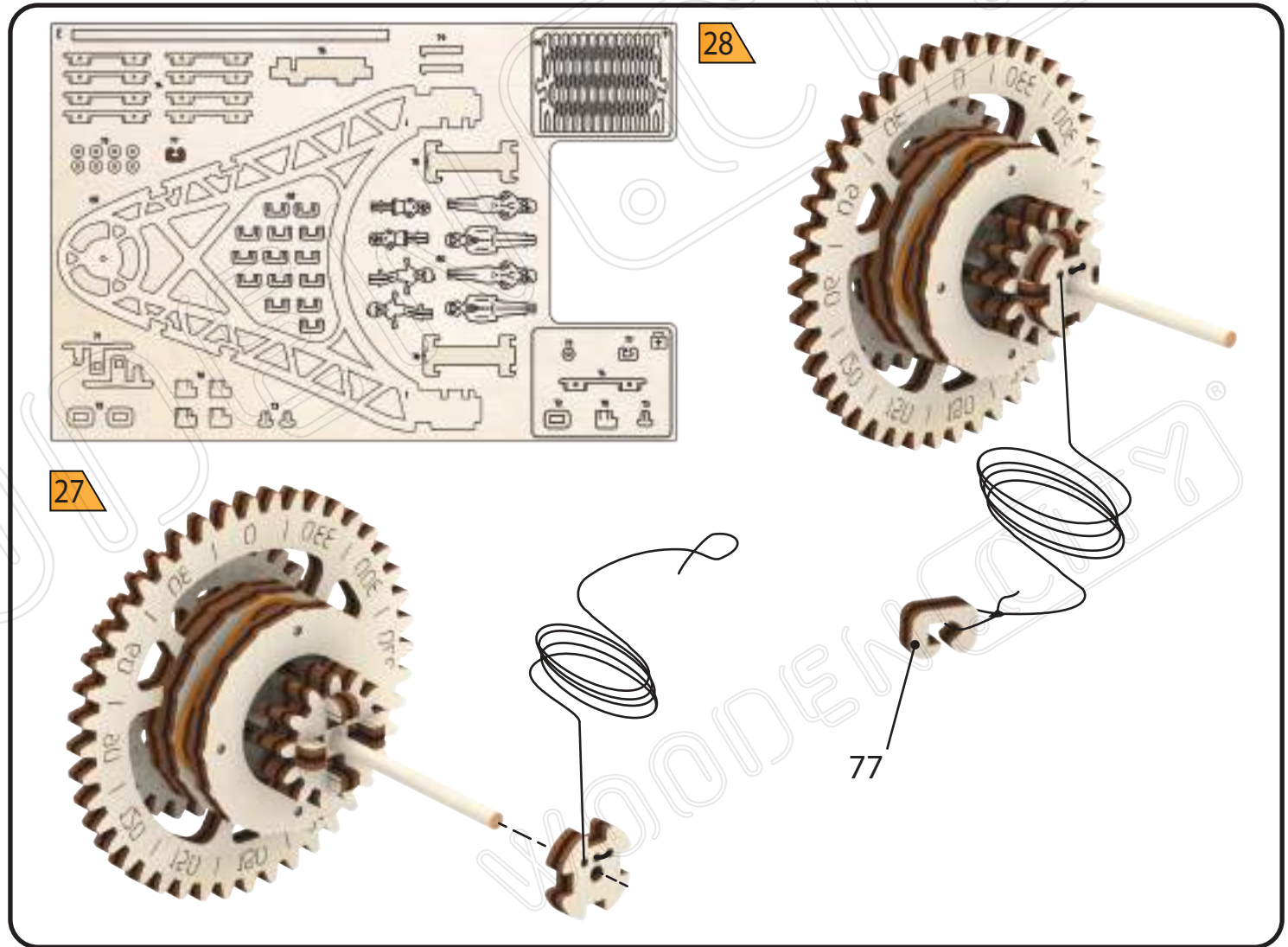
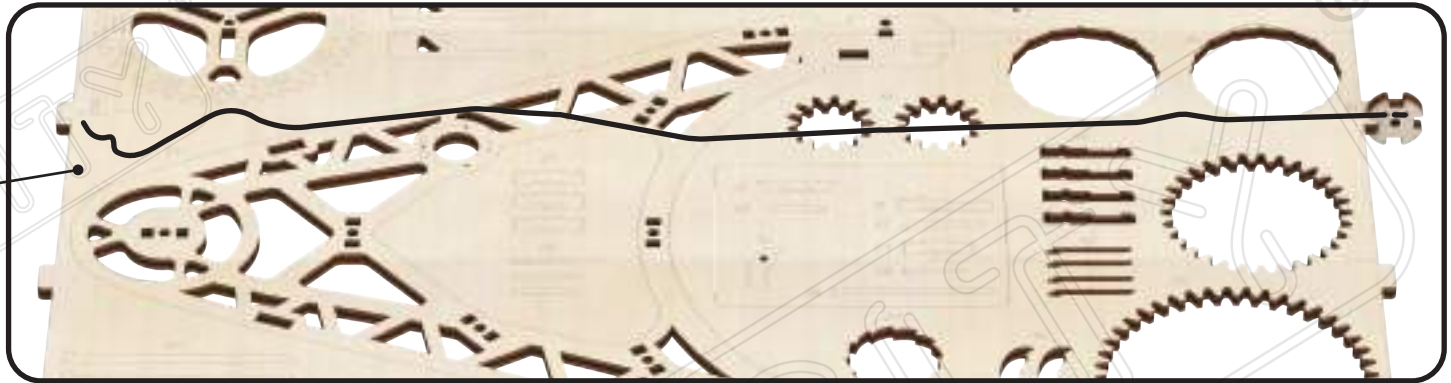
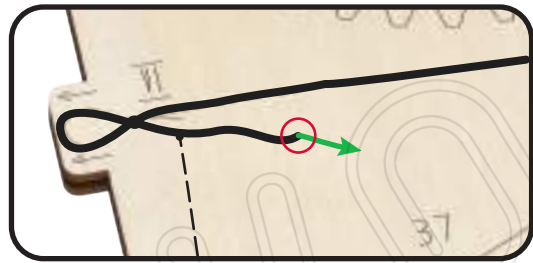
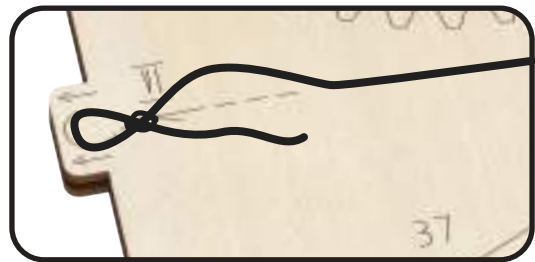
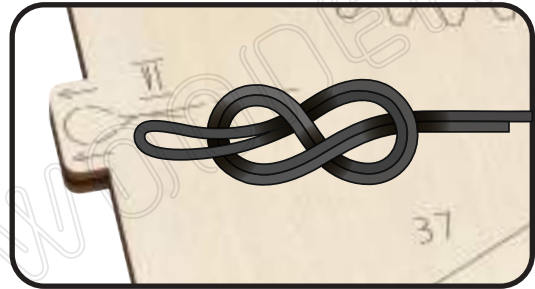

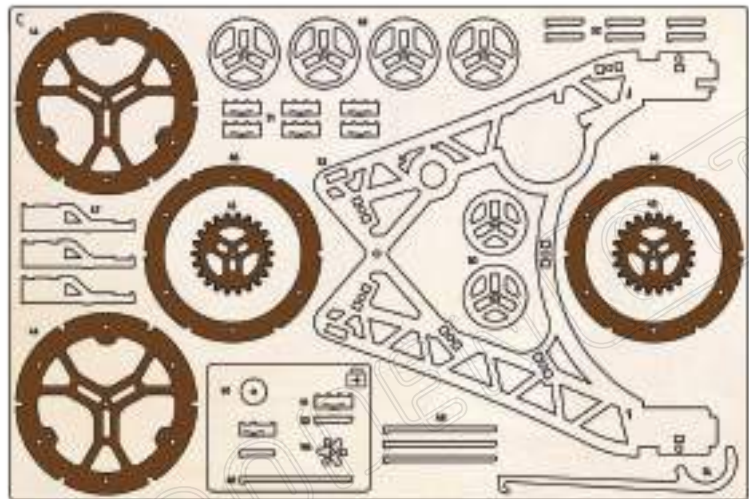

1

6x16 mm

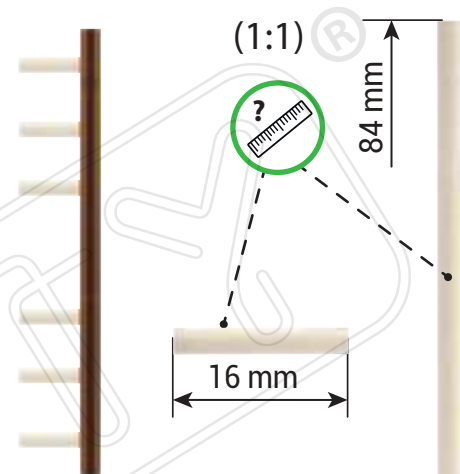
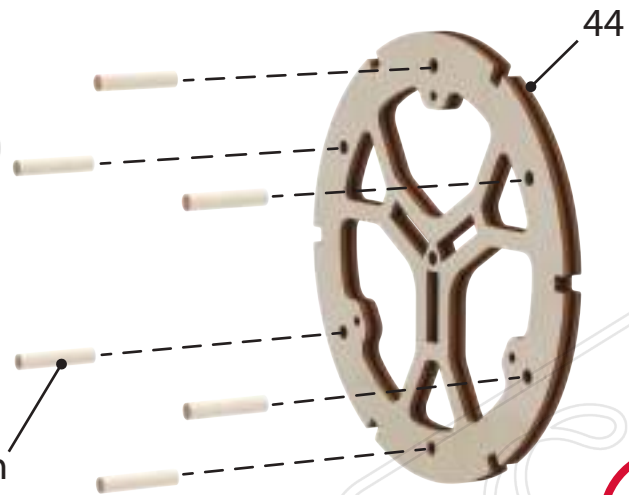

2

3

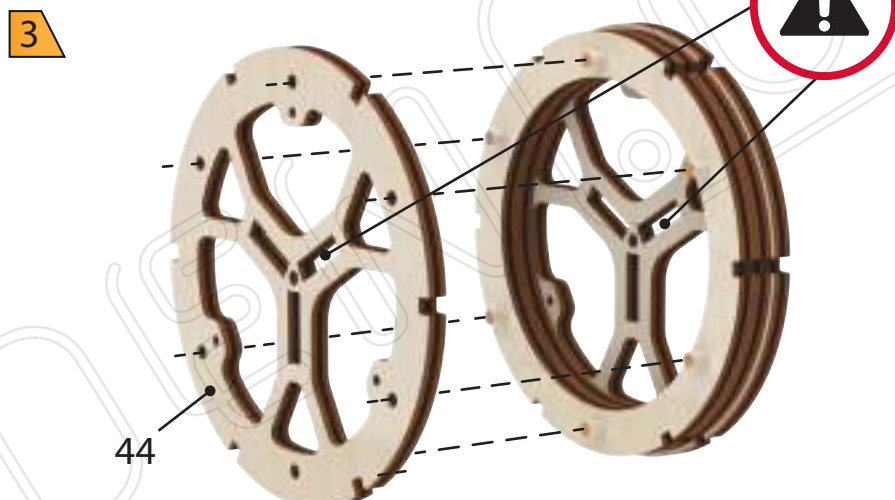
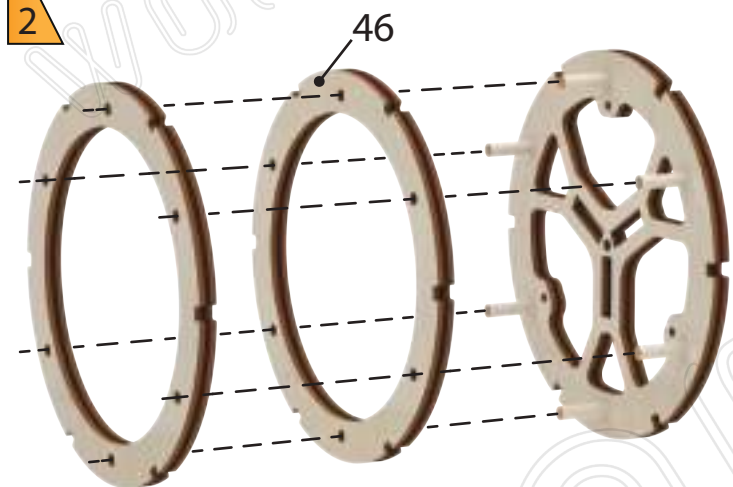

4

5

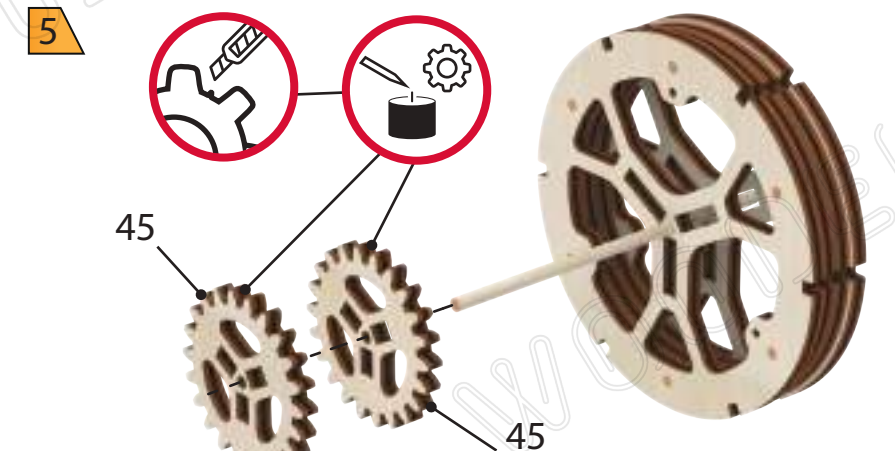

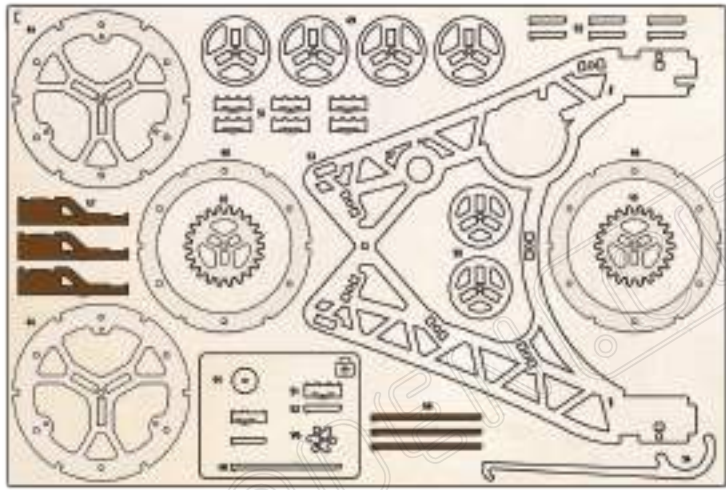

6

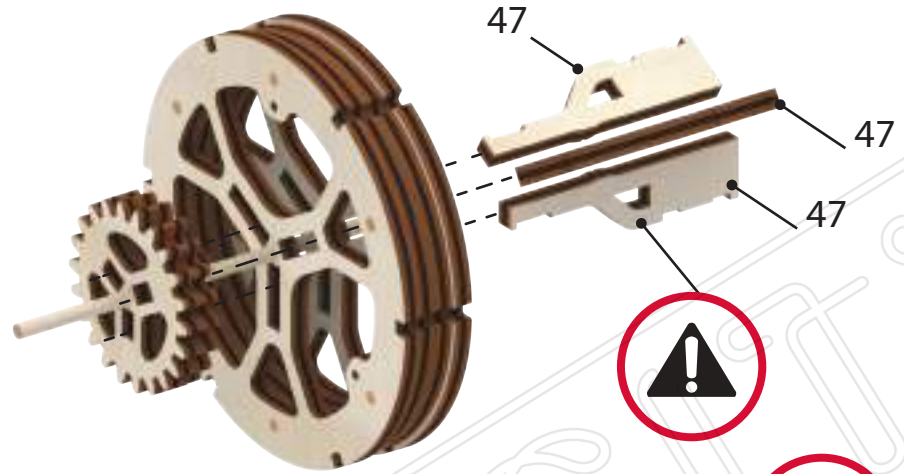

7



8

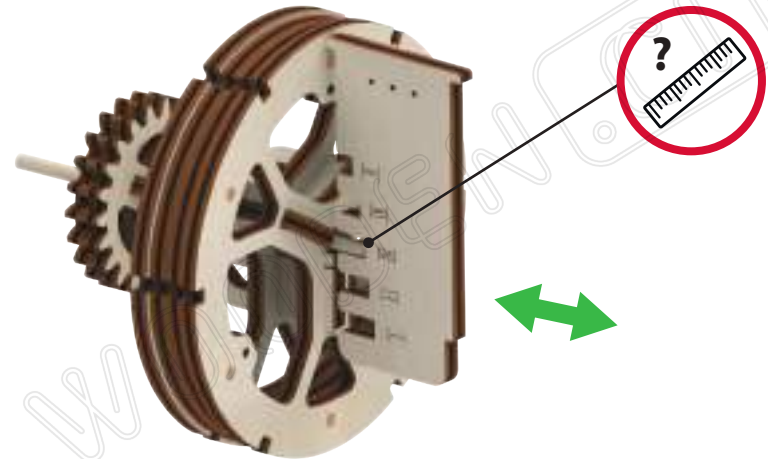

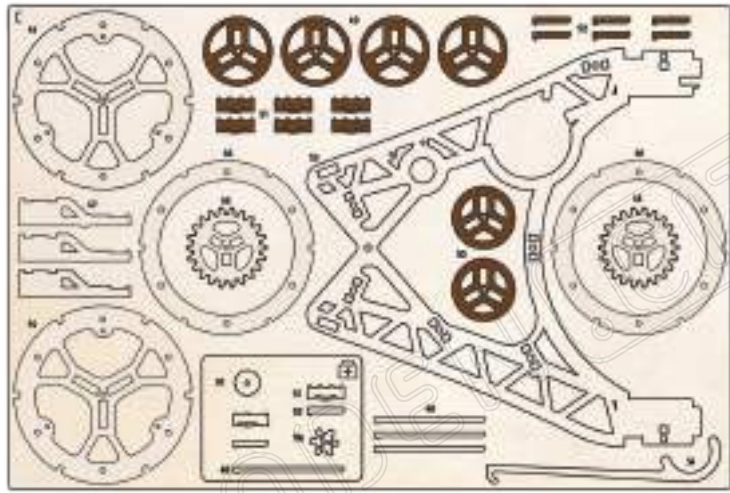

1

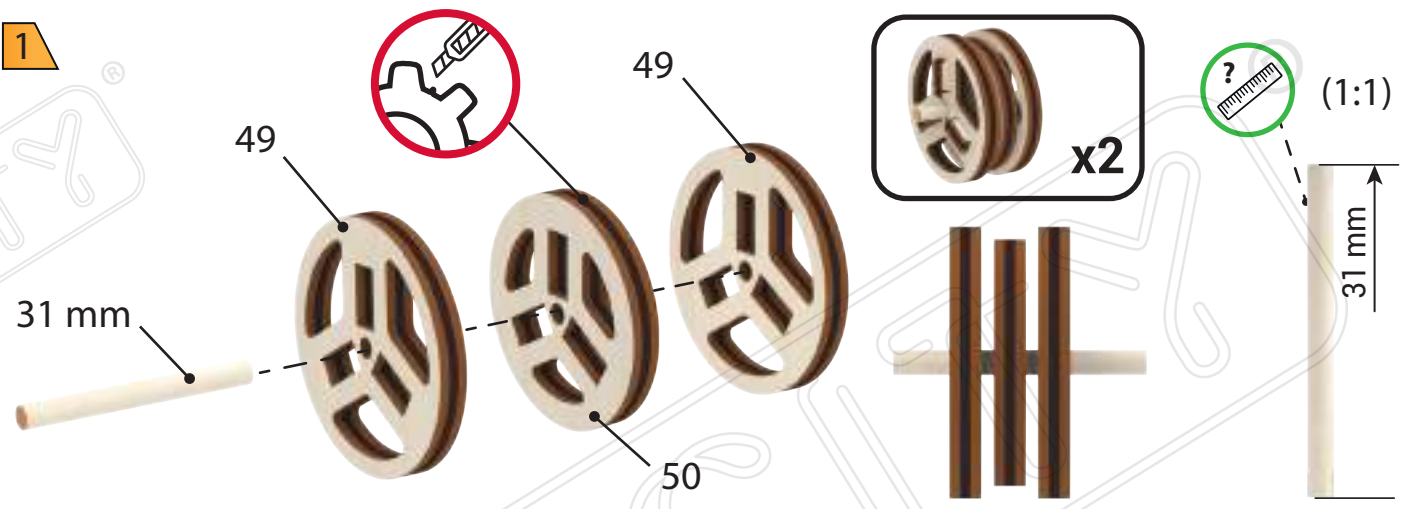

2

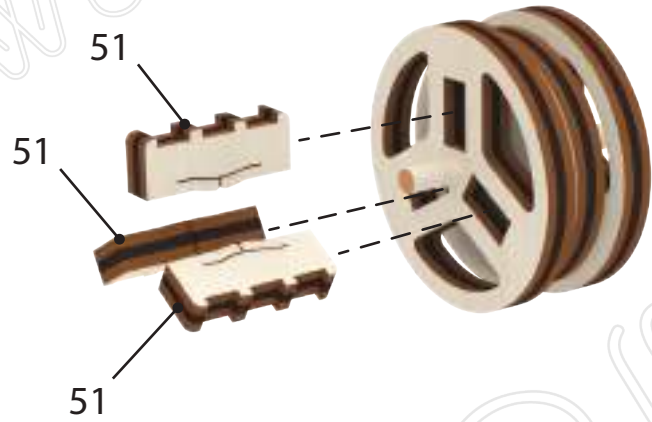

3

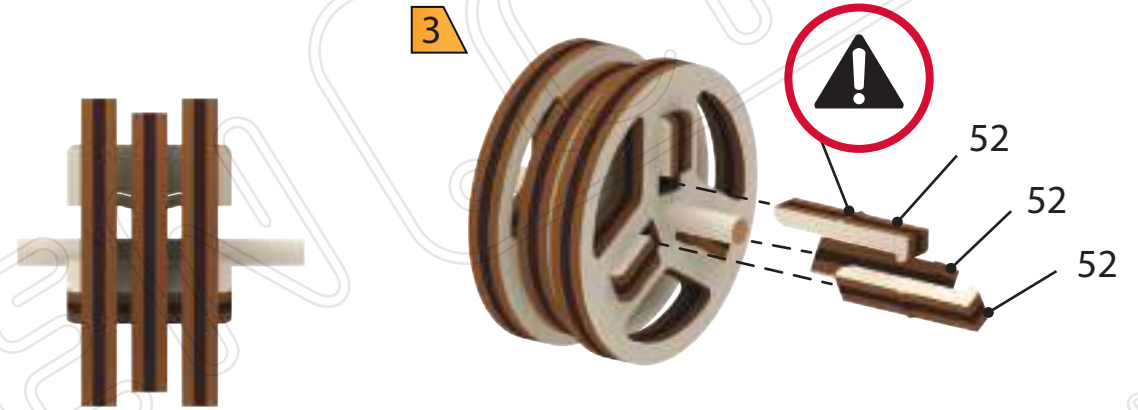

4



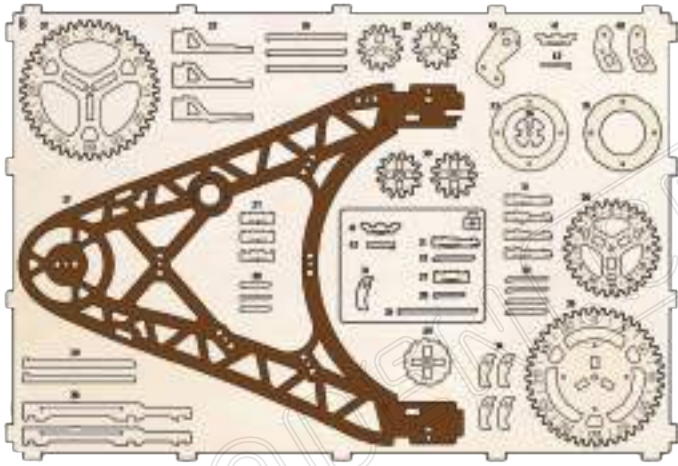

1

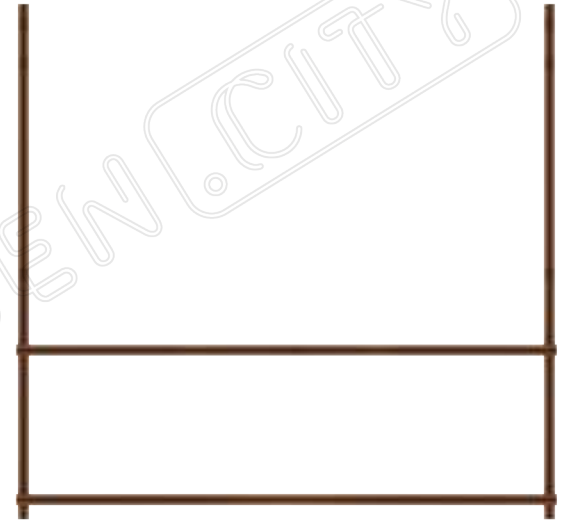
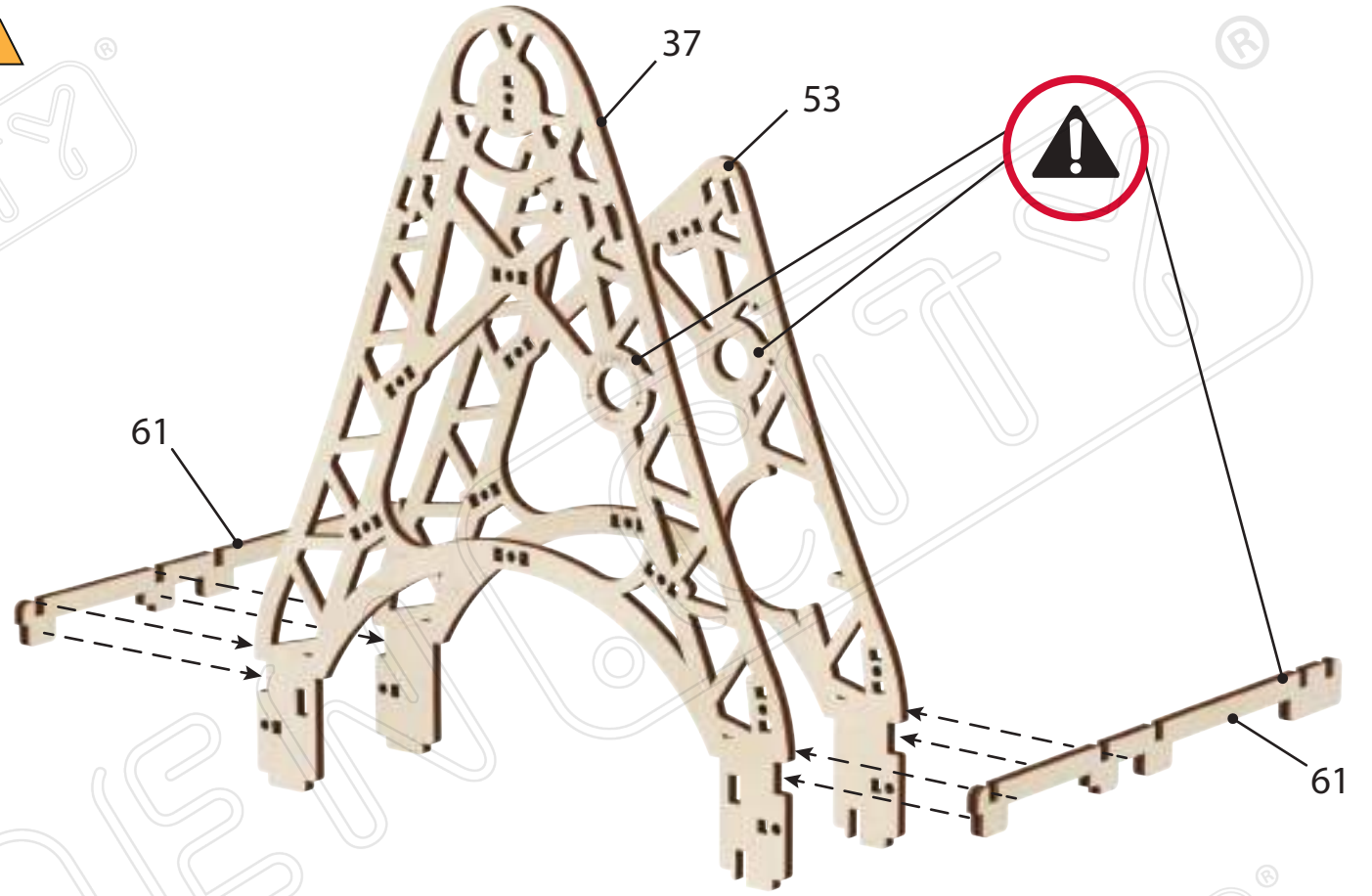
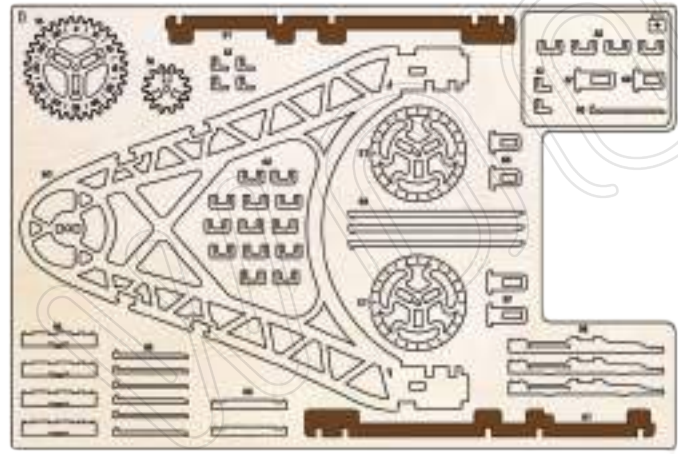
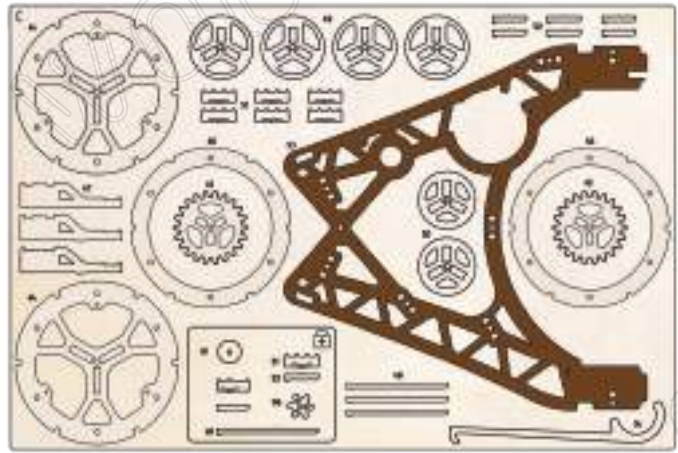

2

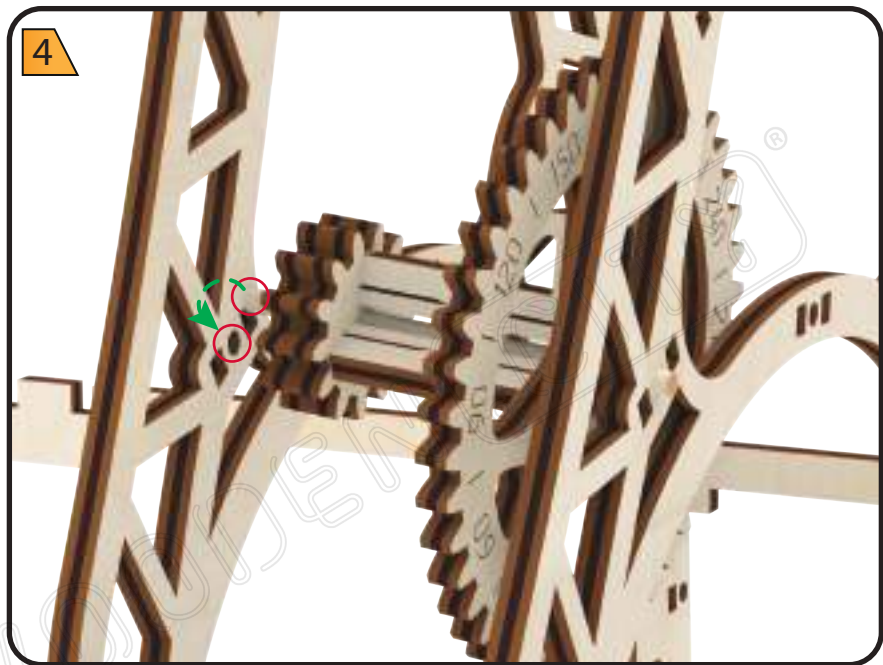
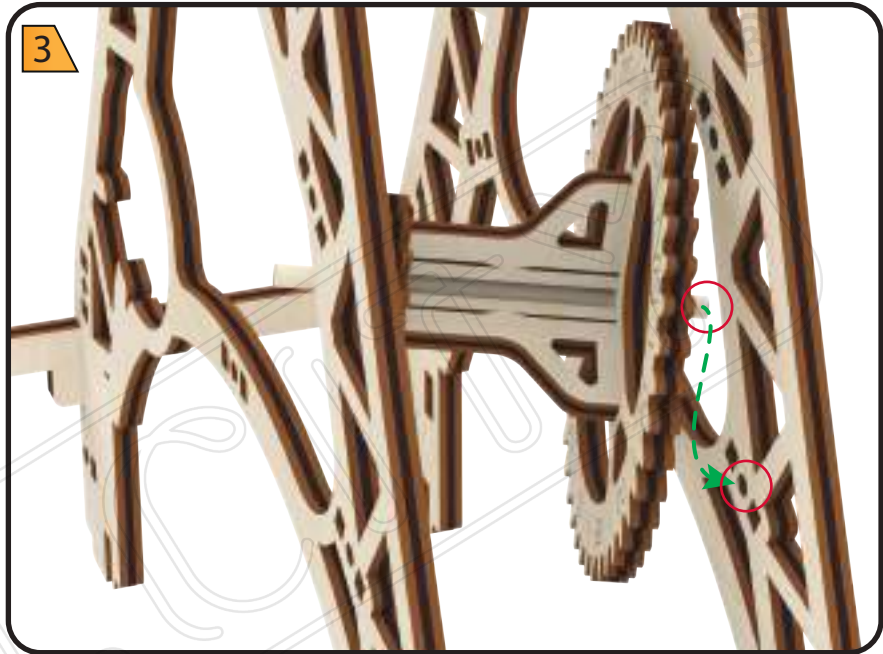
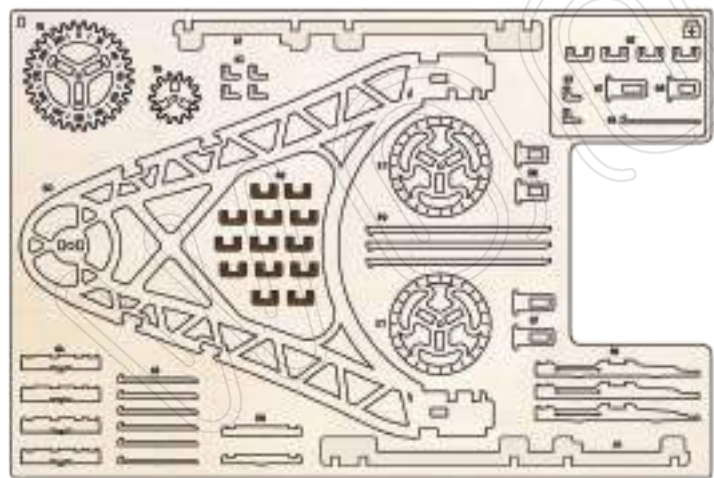
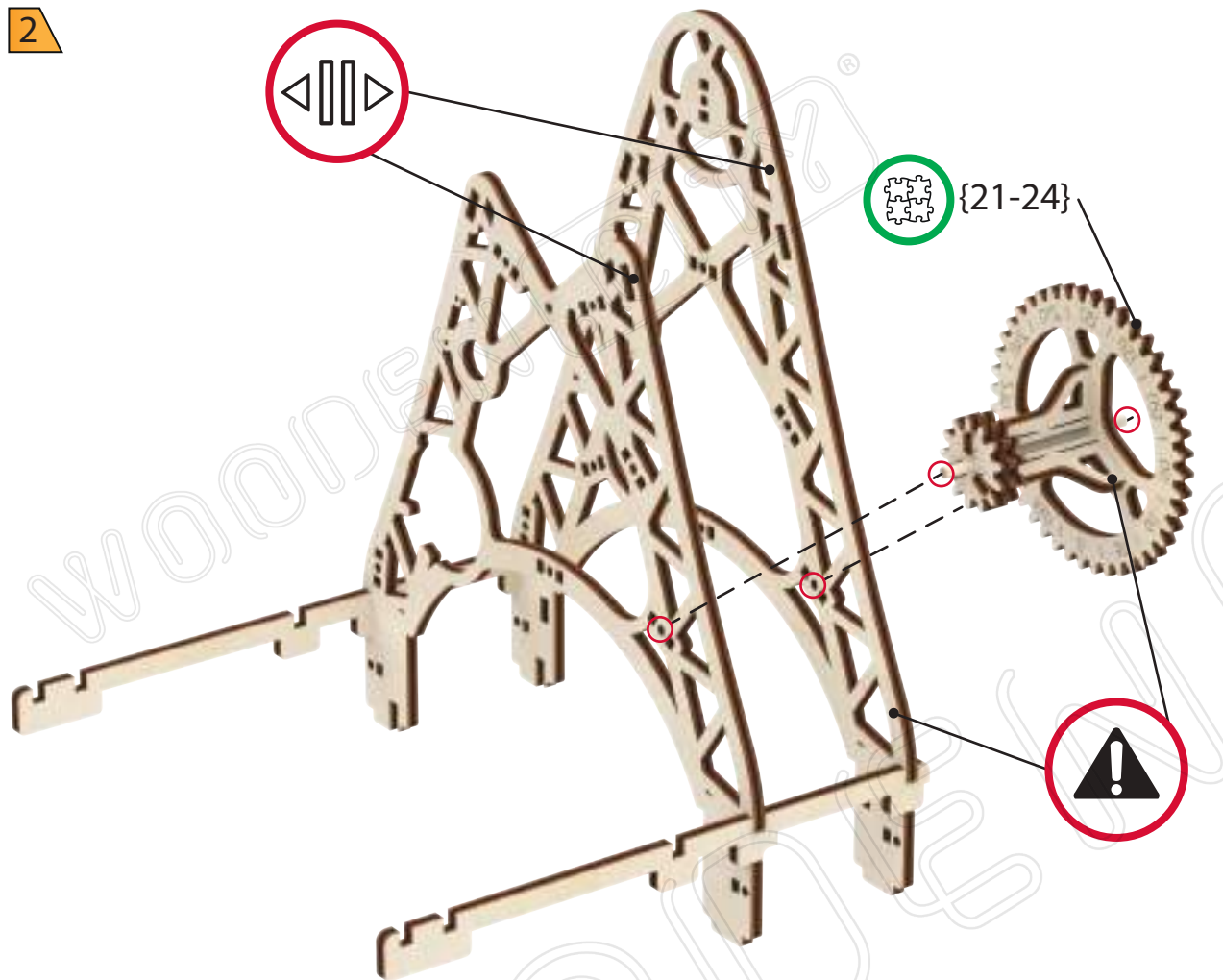

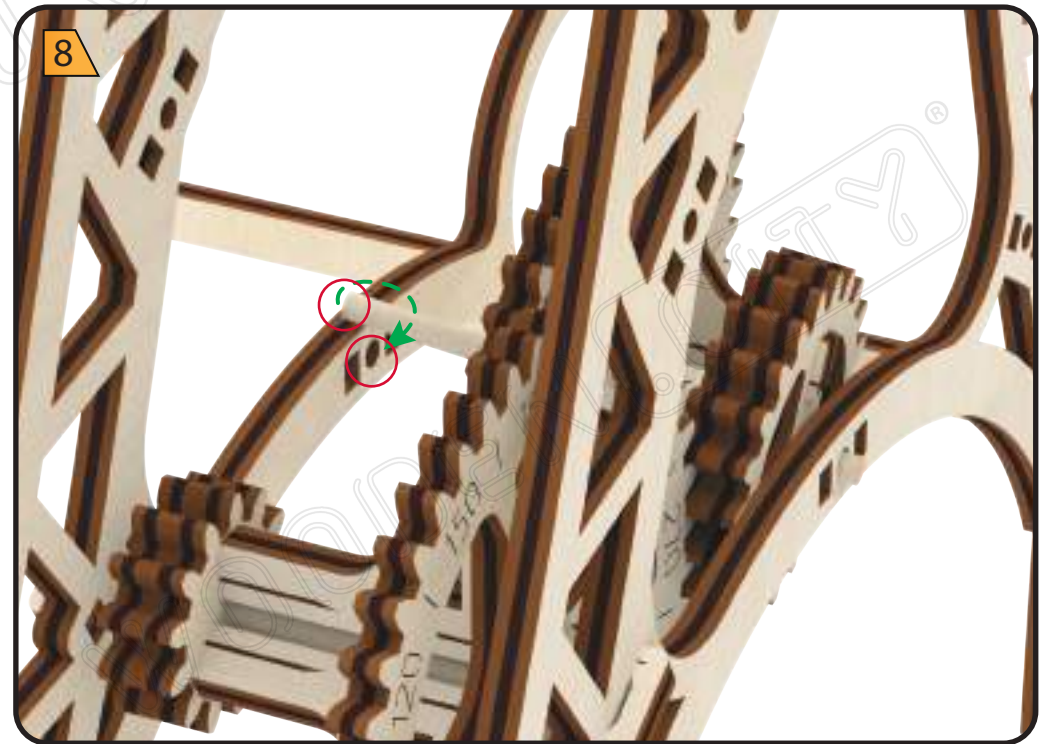
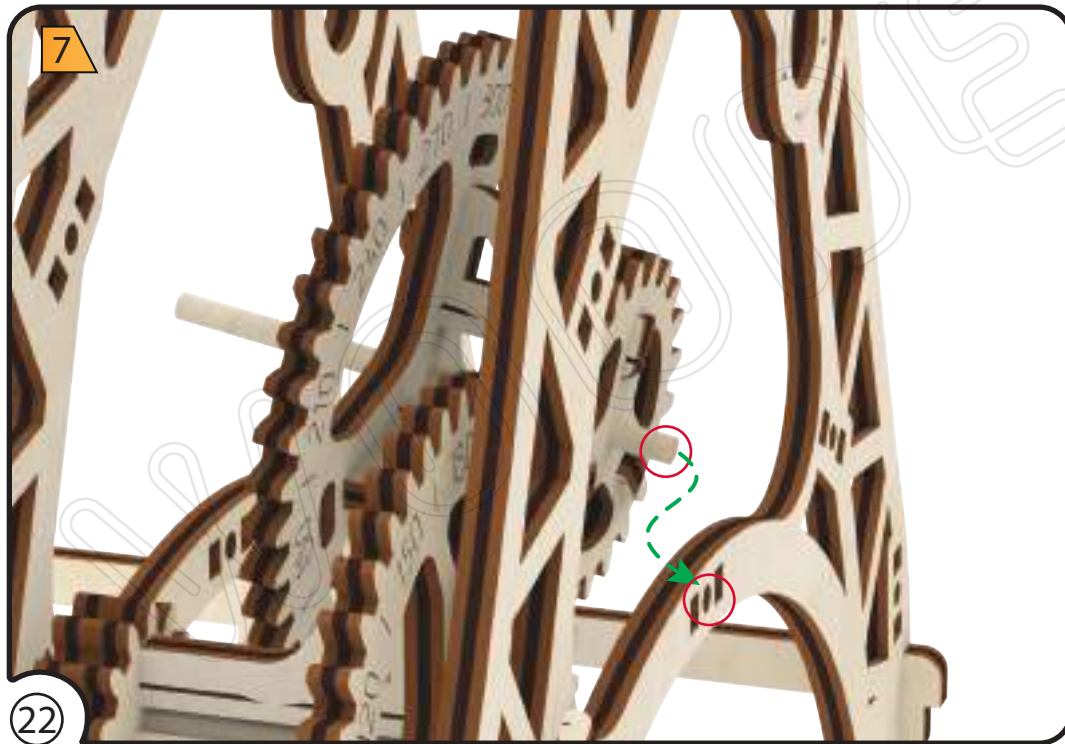
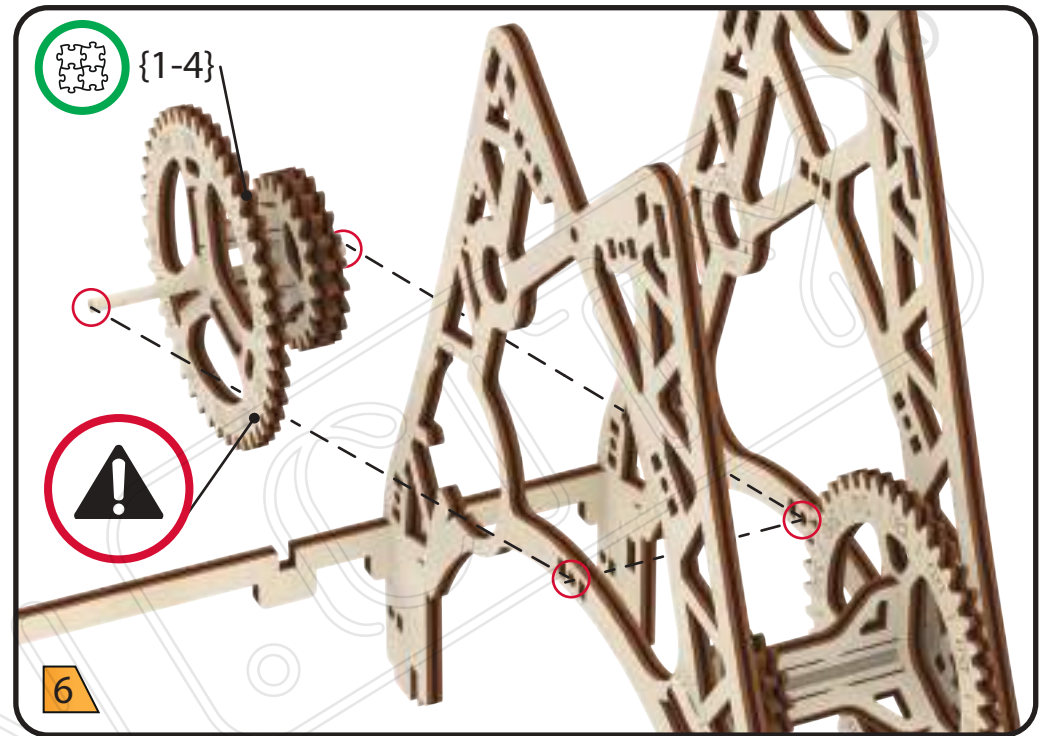
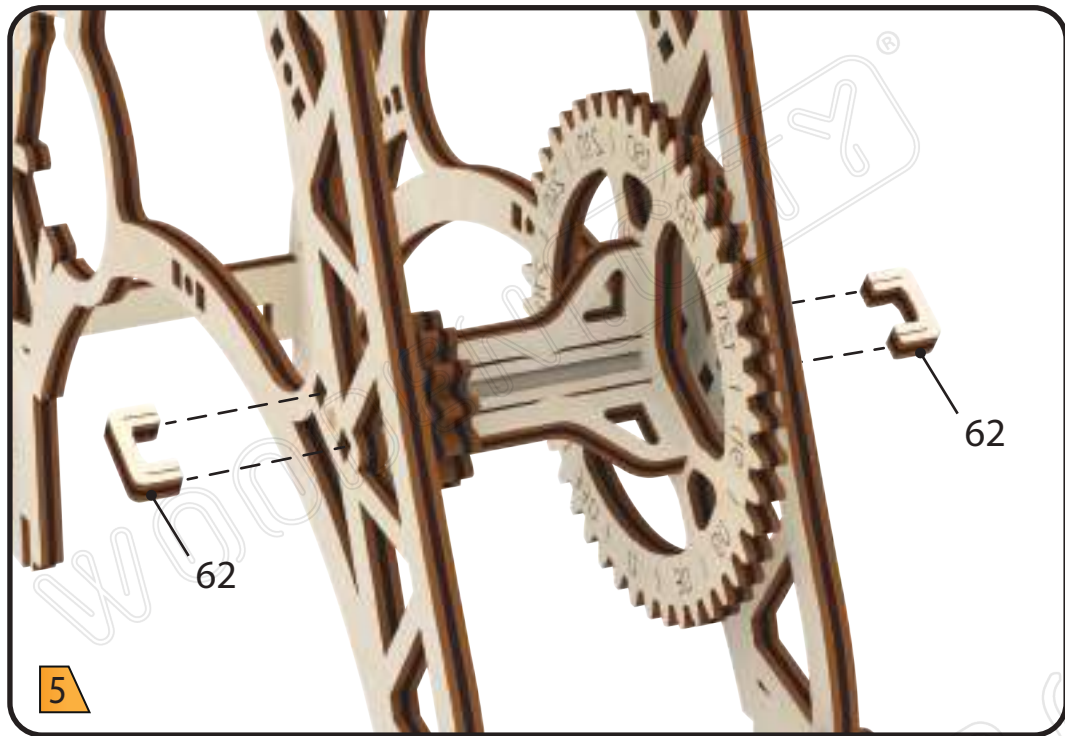

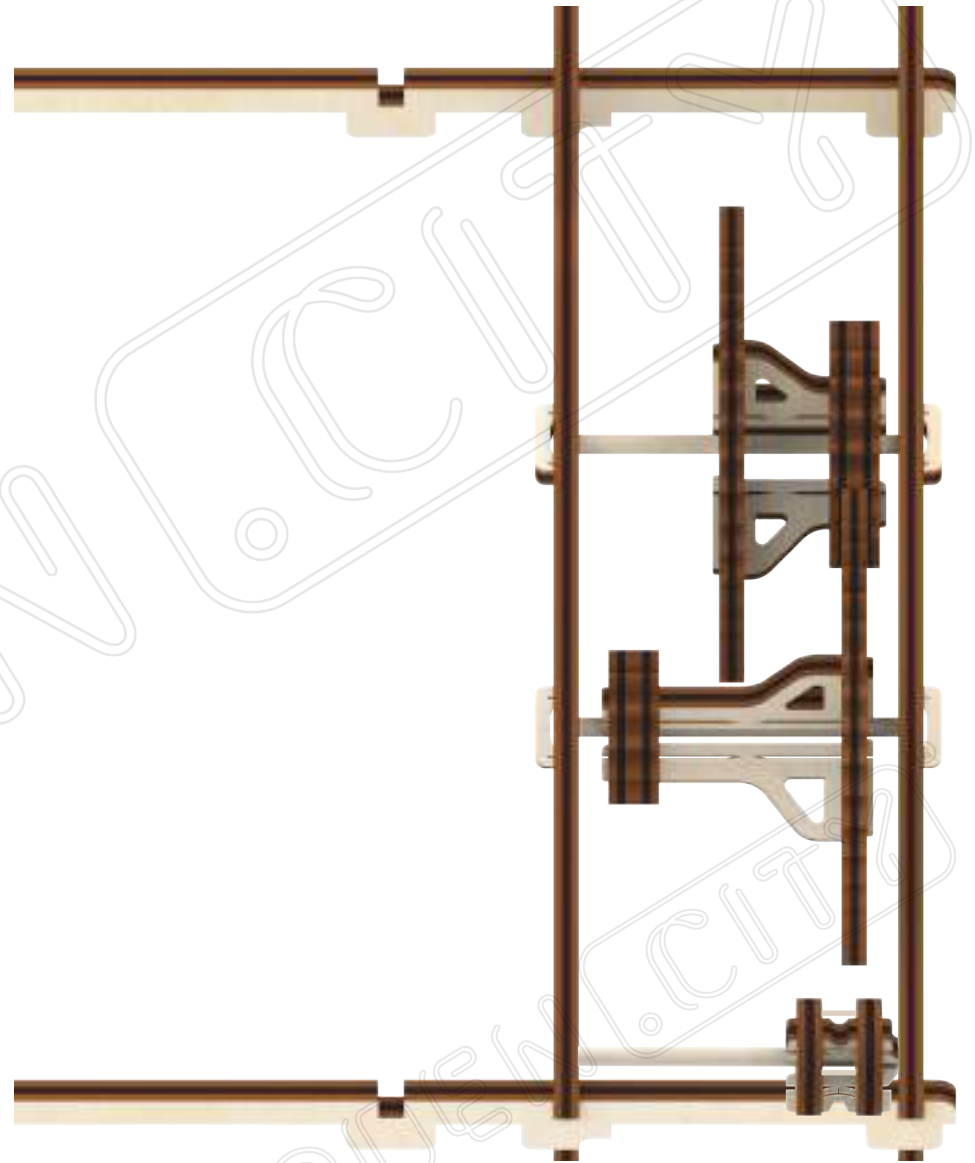
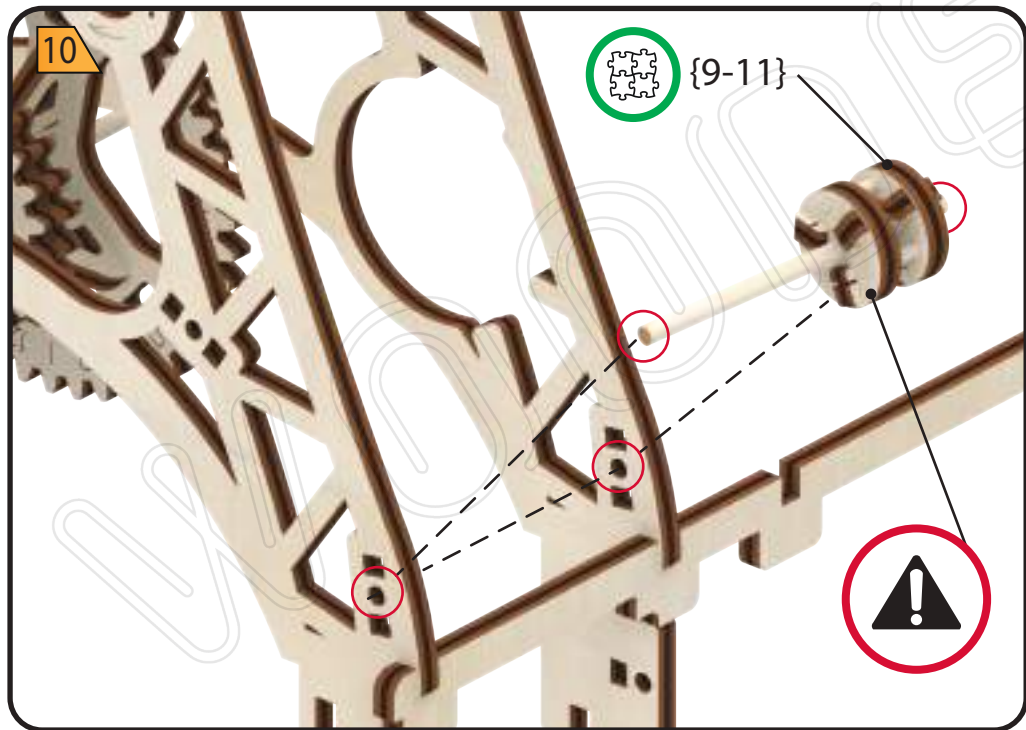
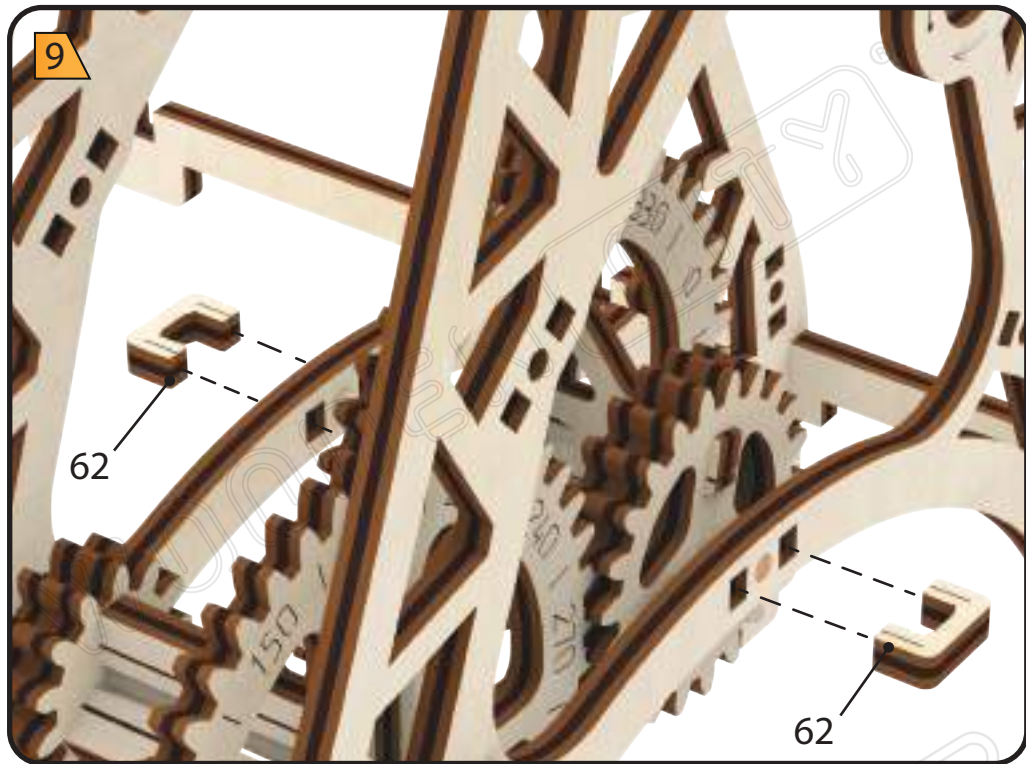

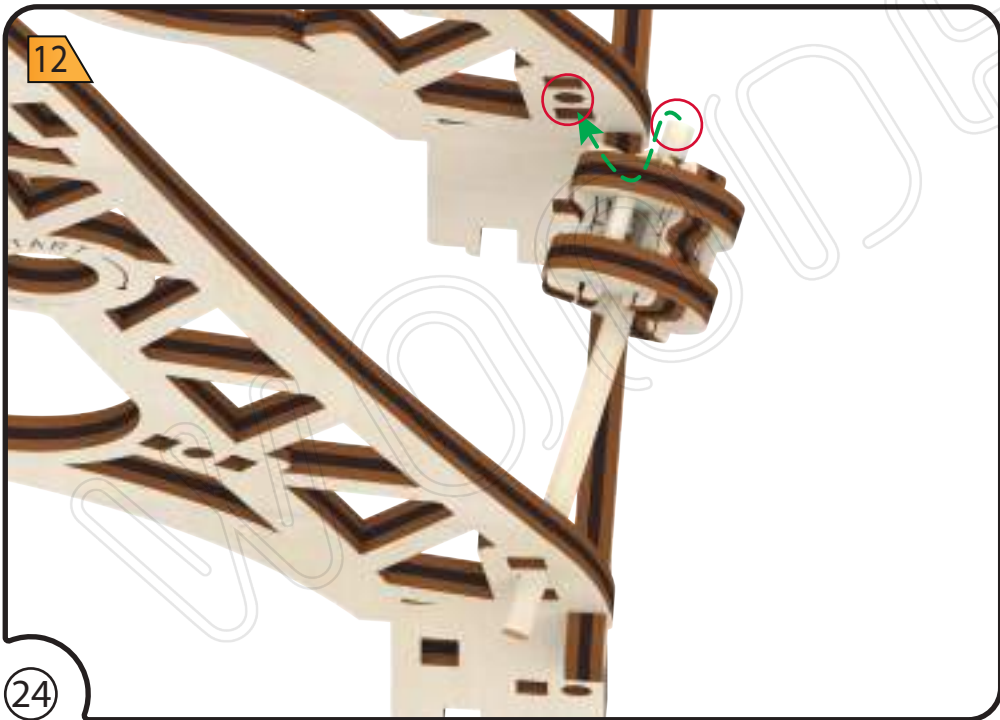

24

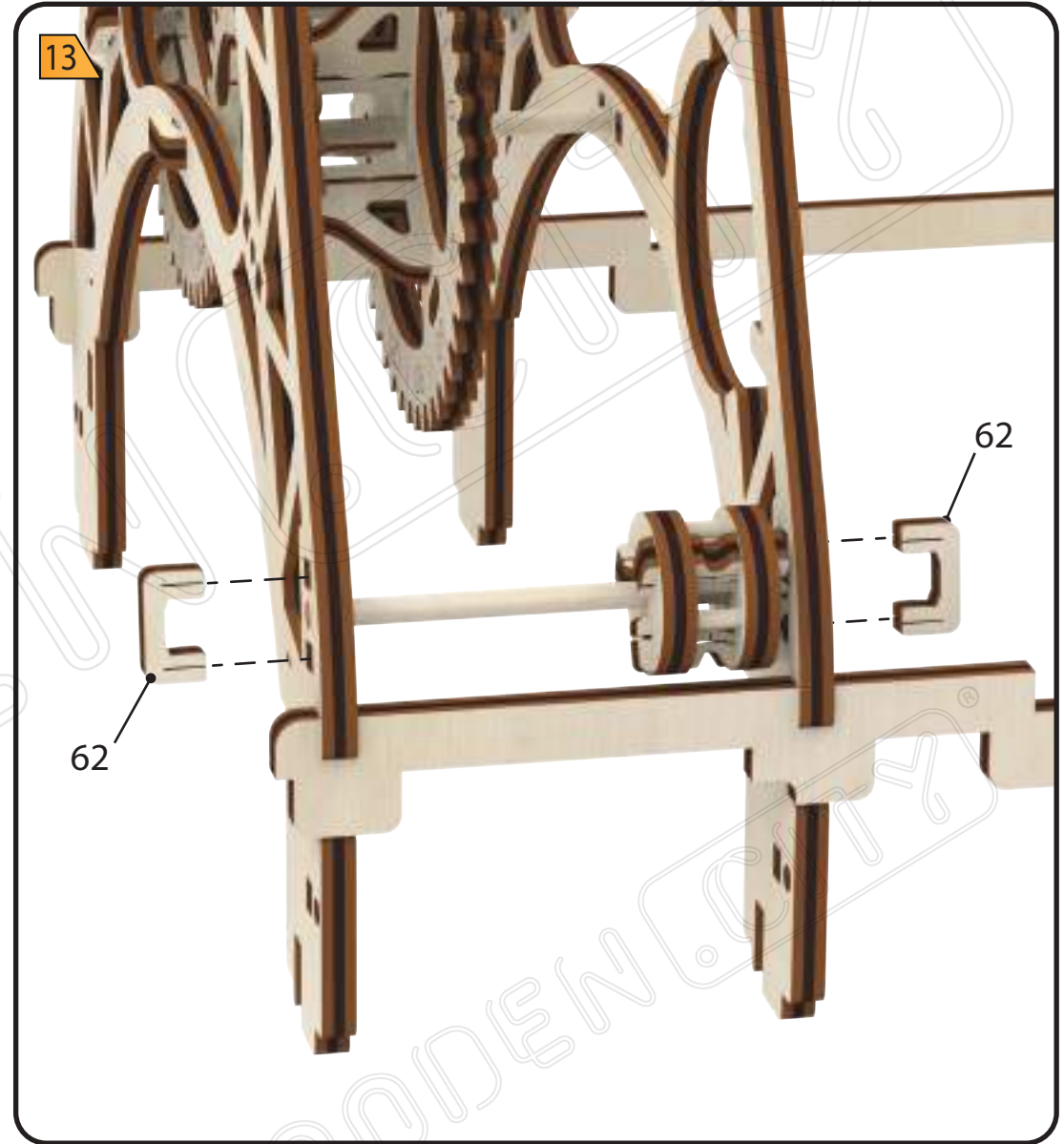

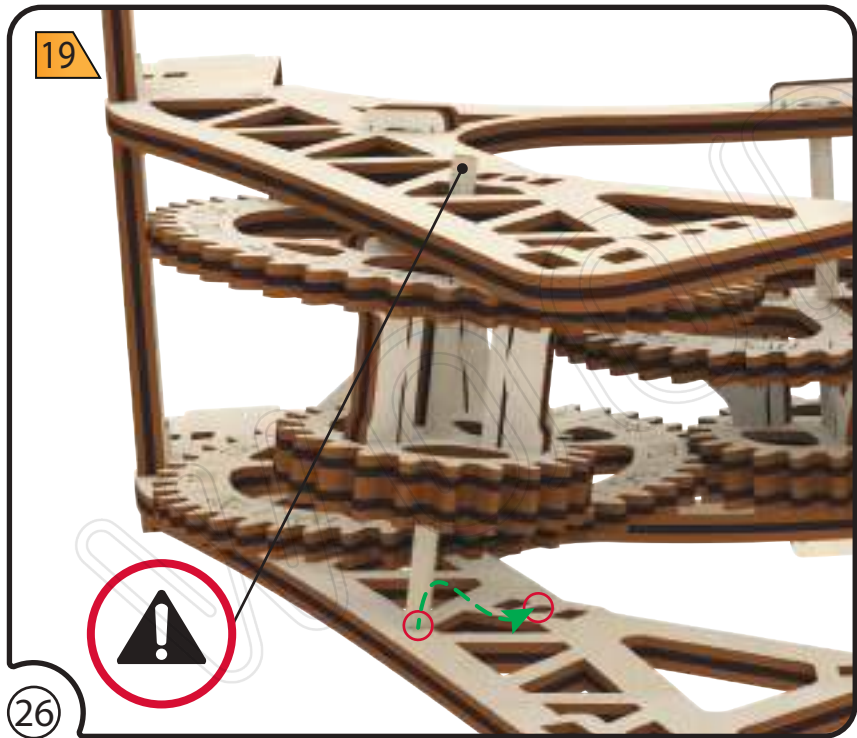
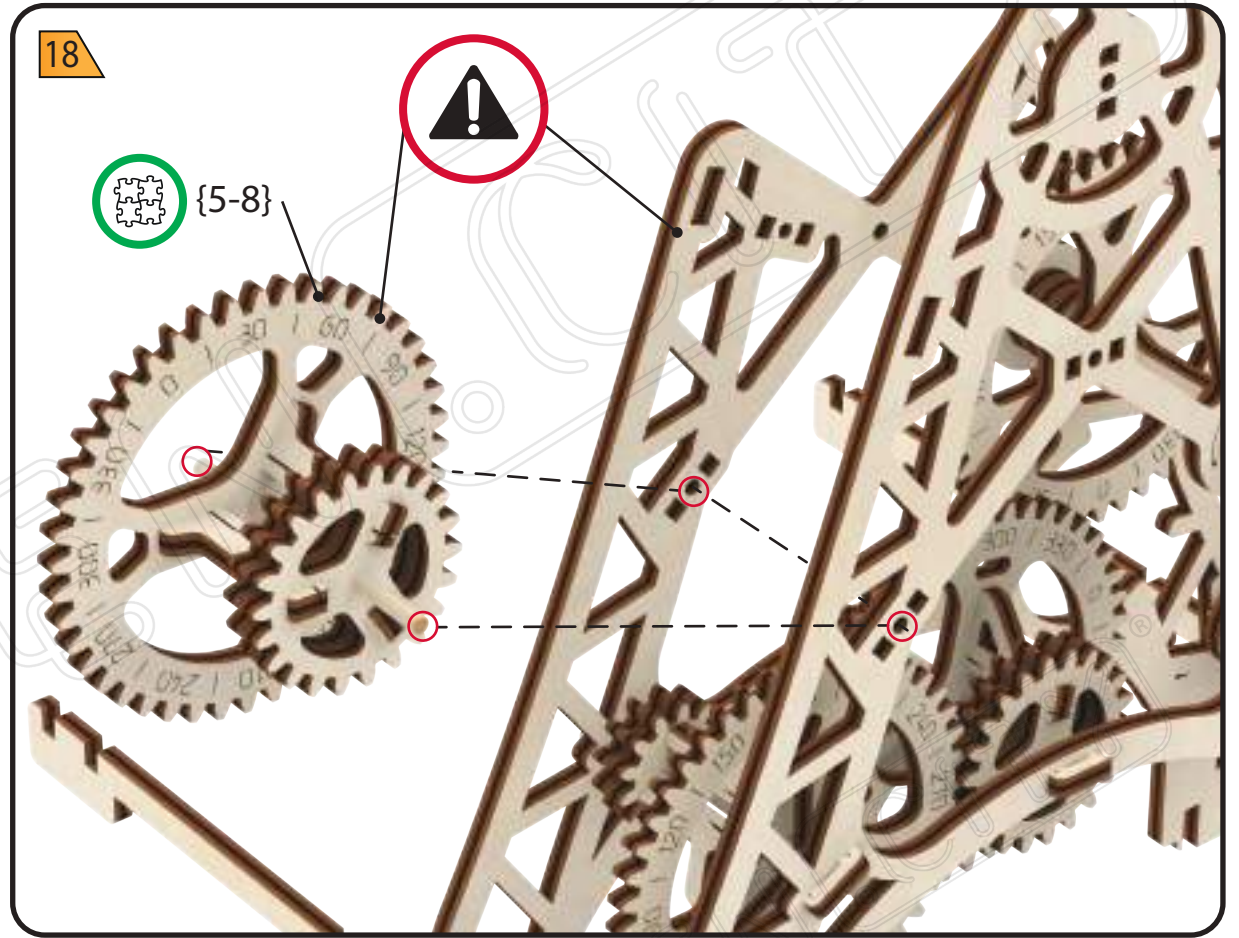
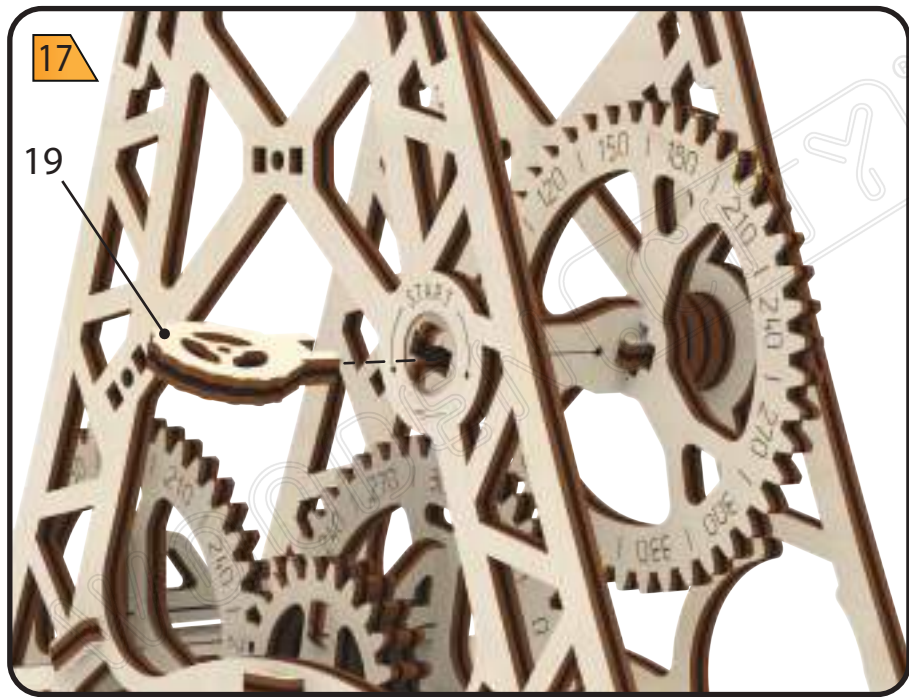

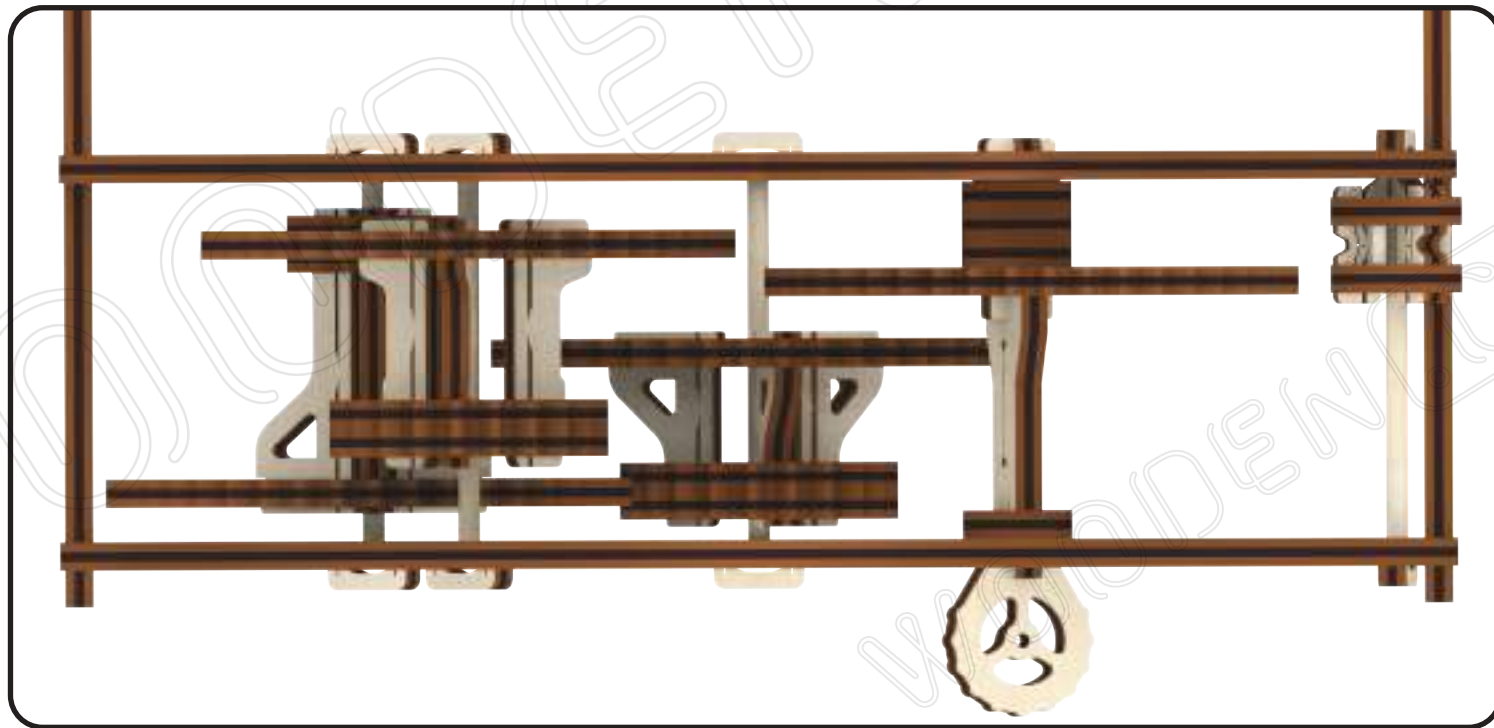
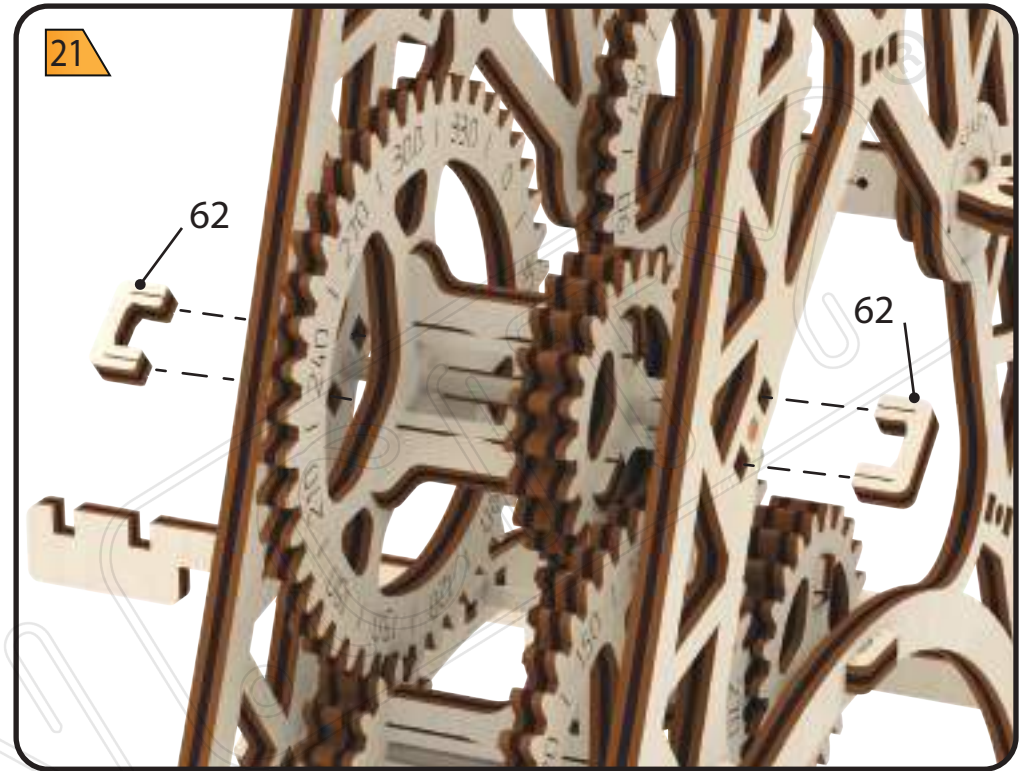
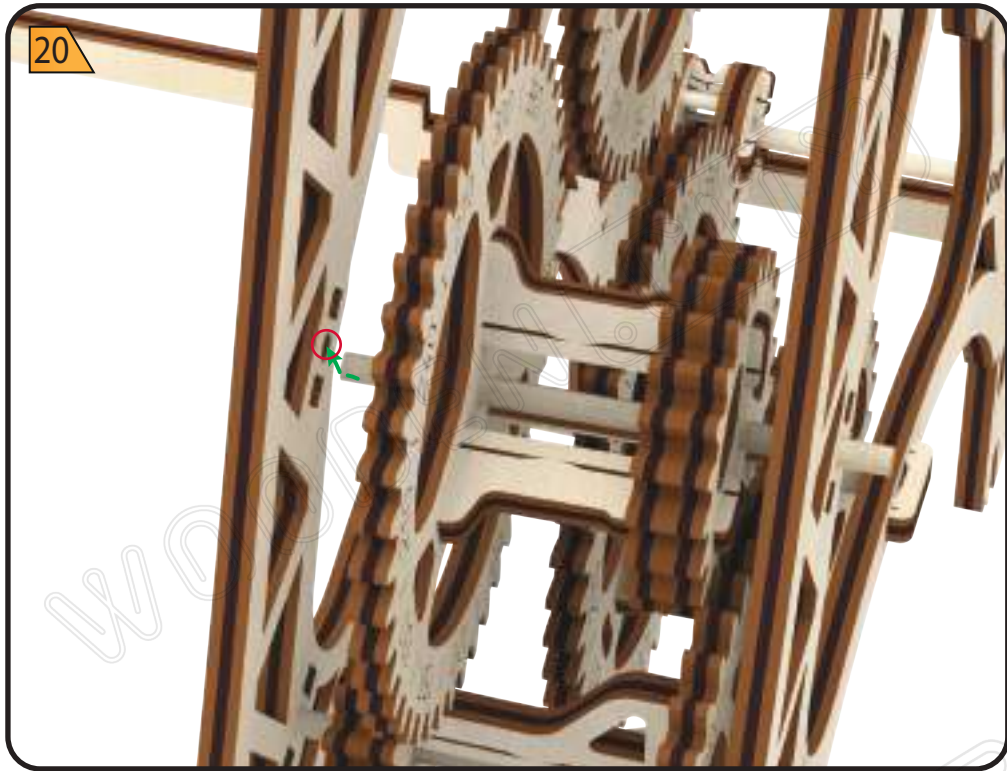

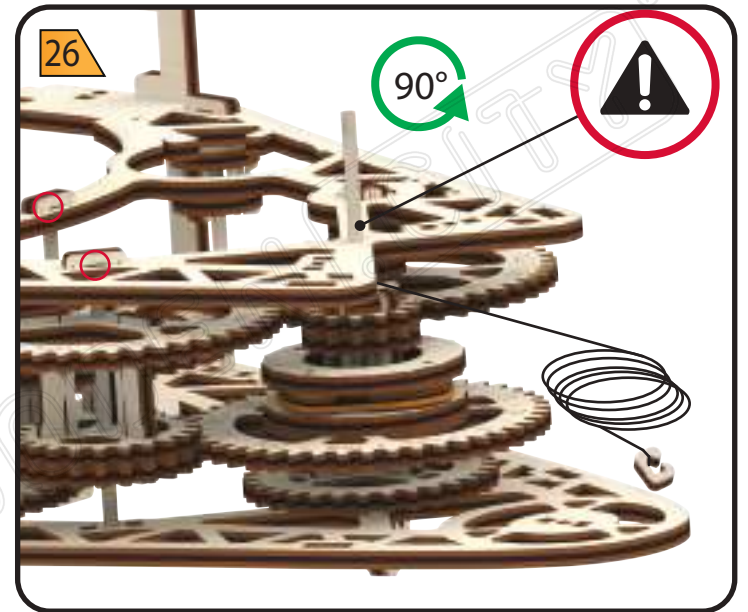
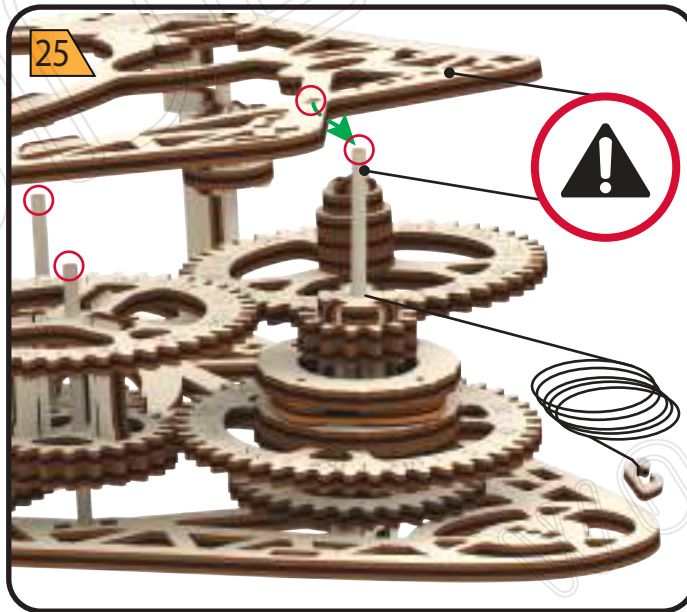
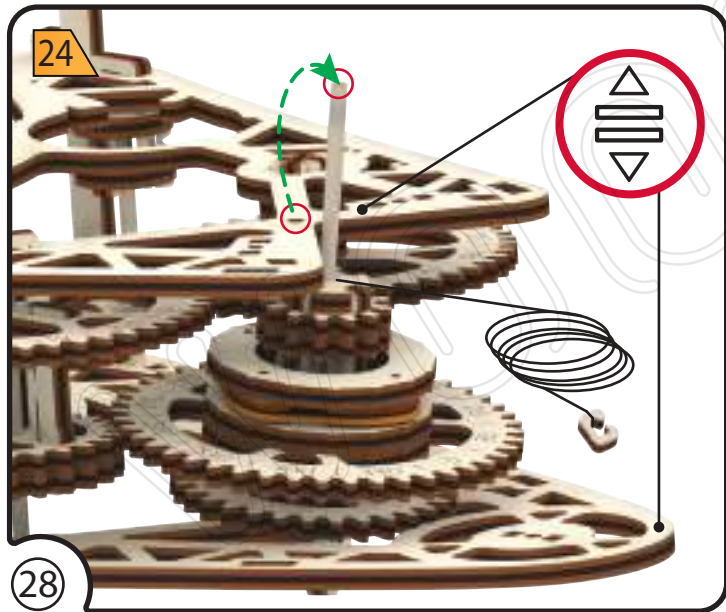
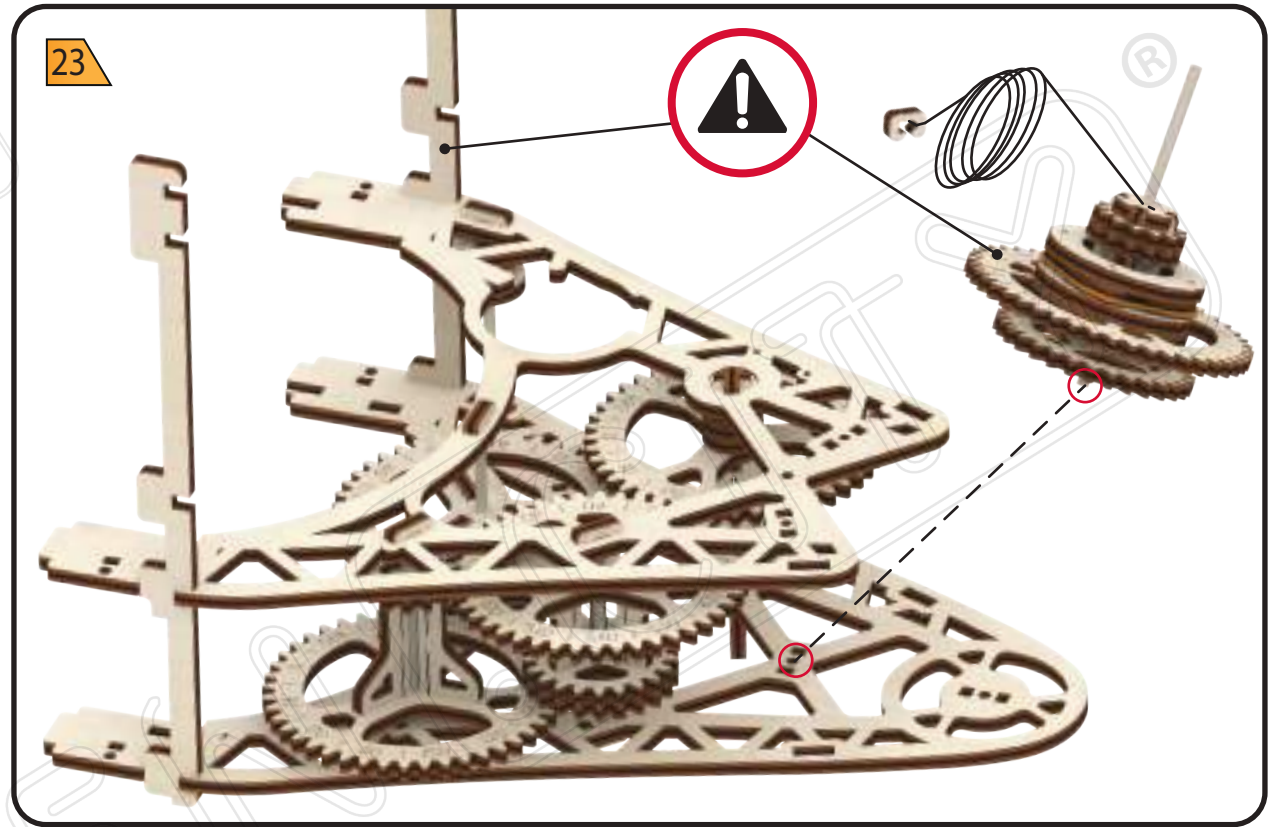
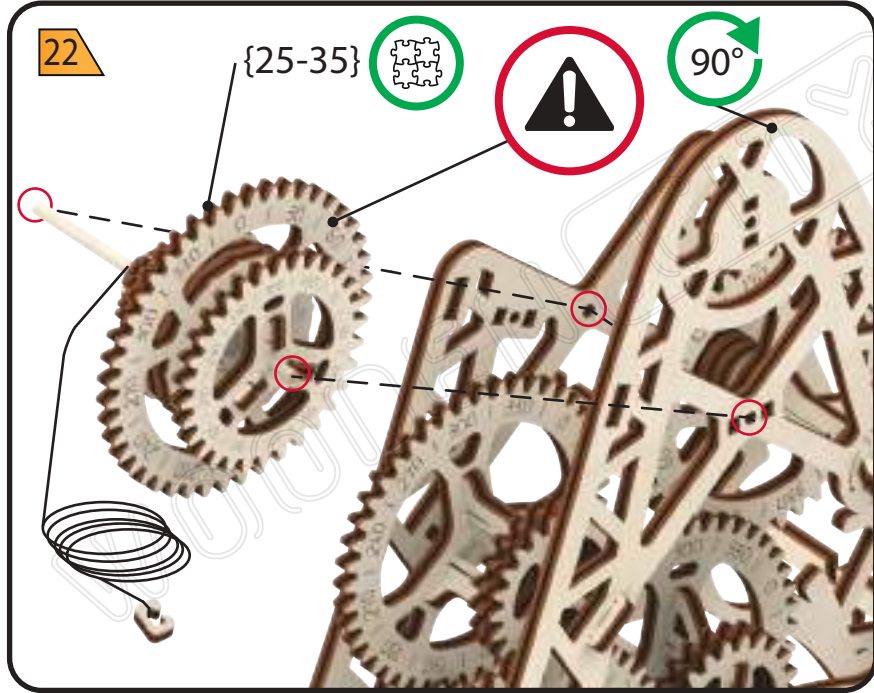

27

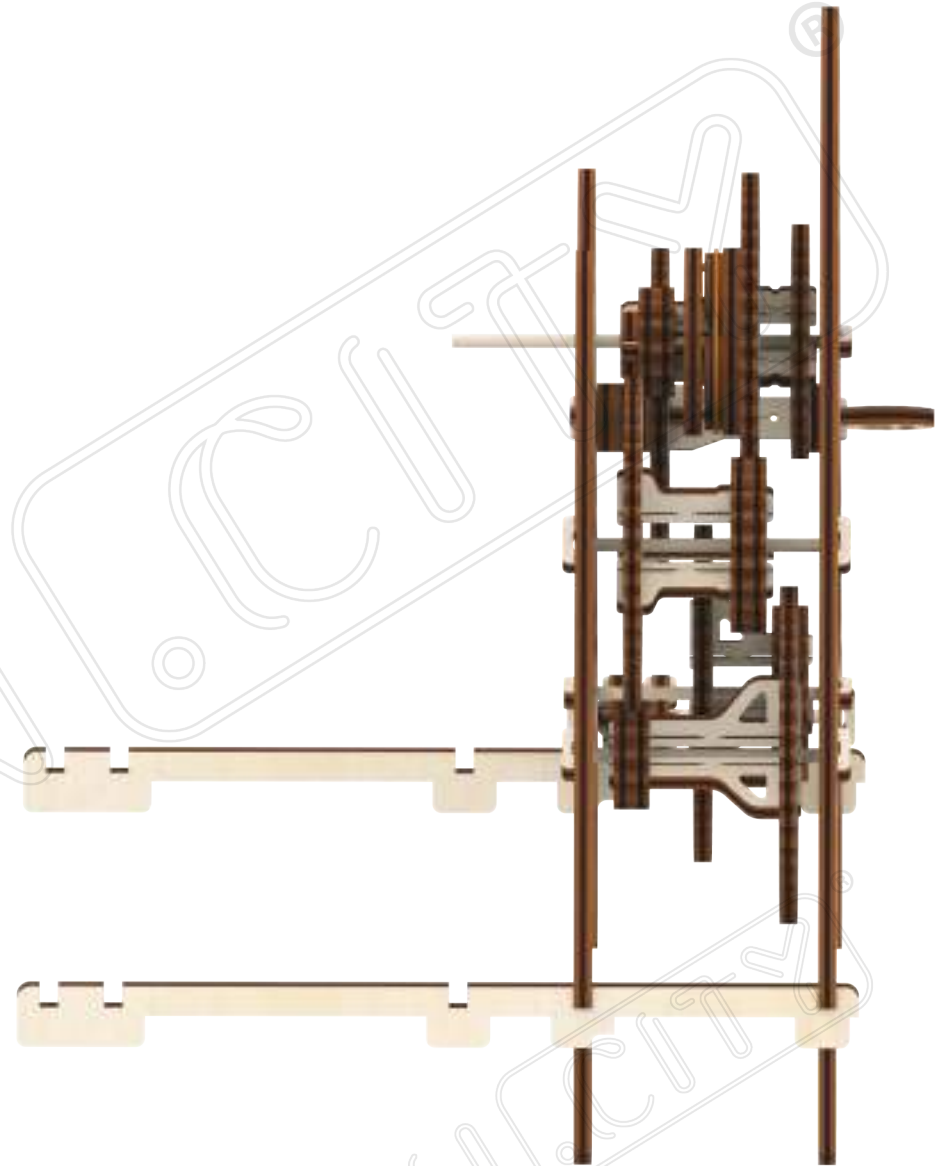
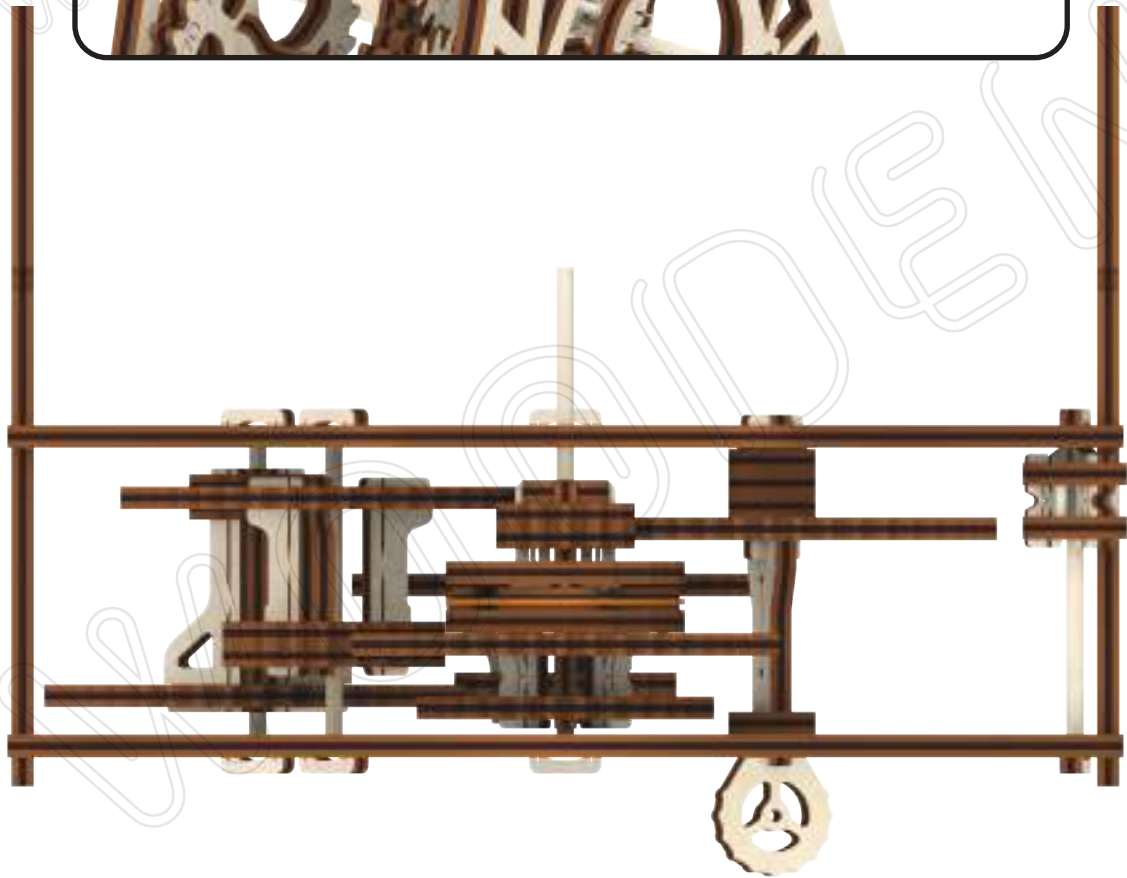
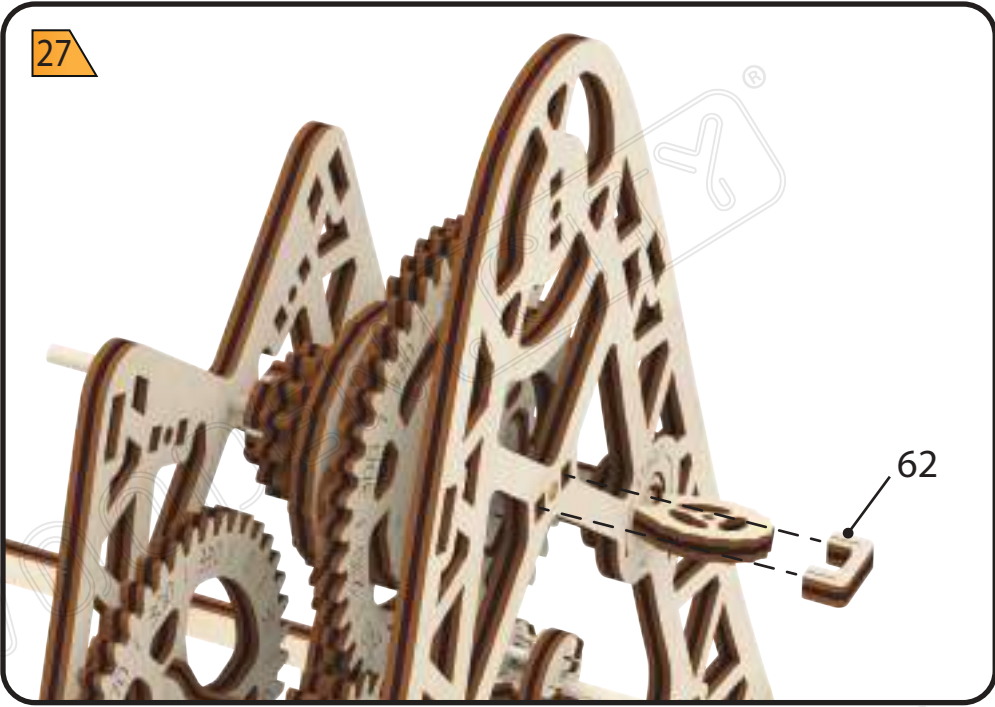

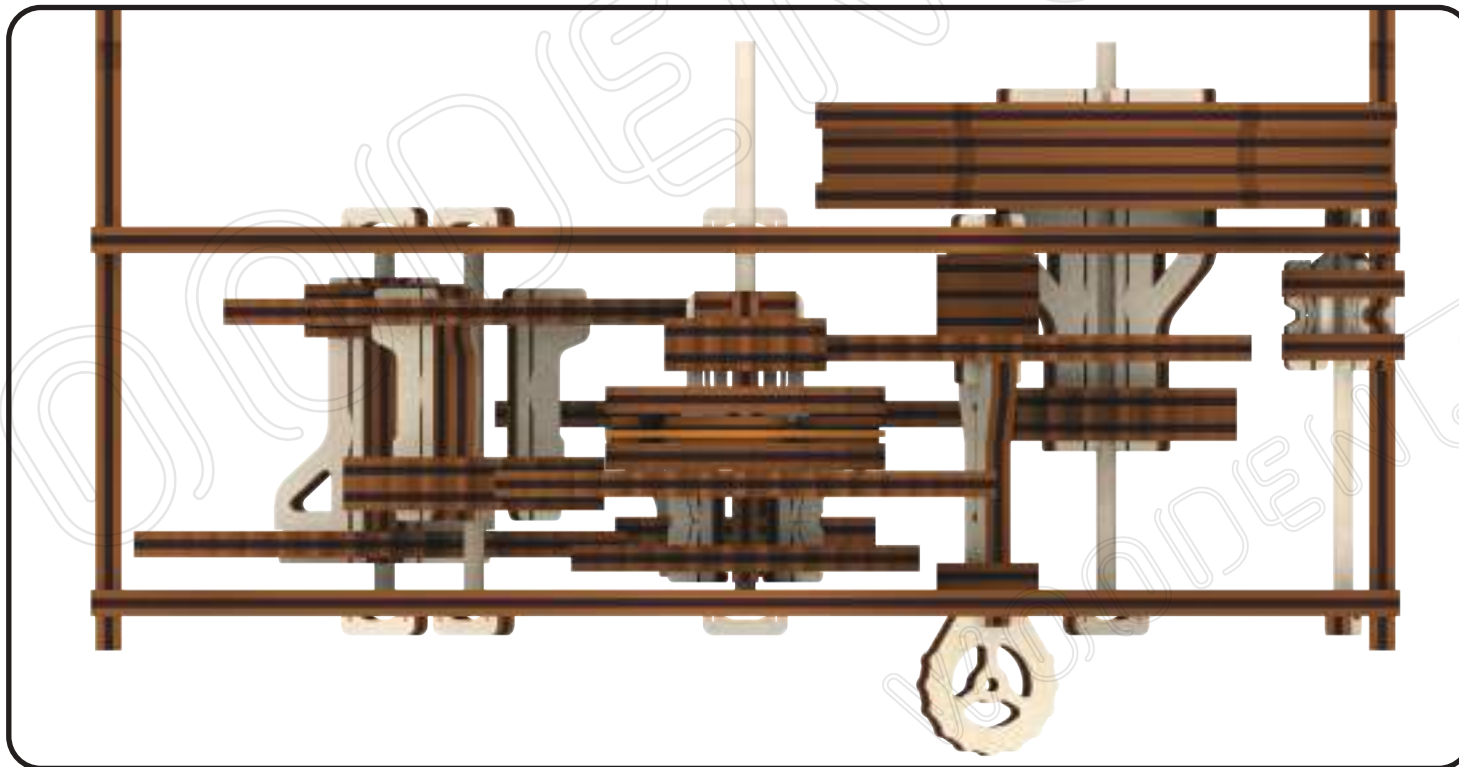
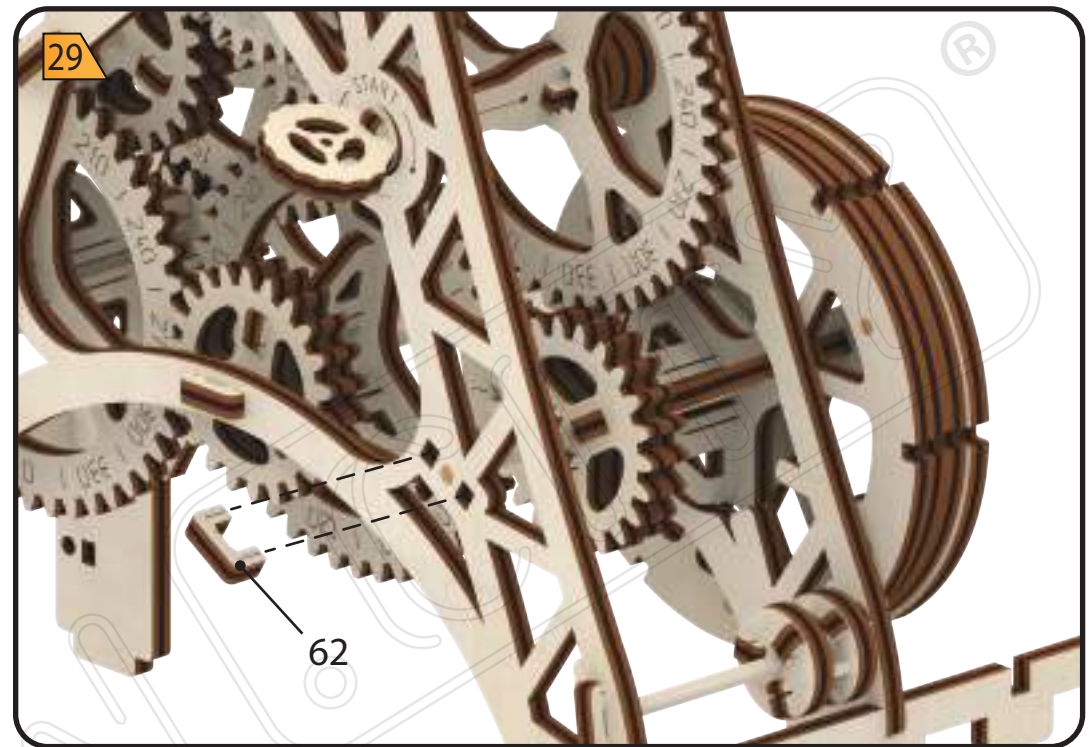
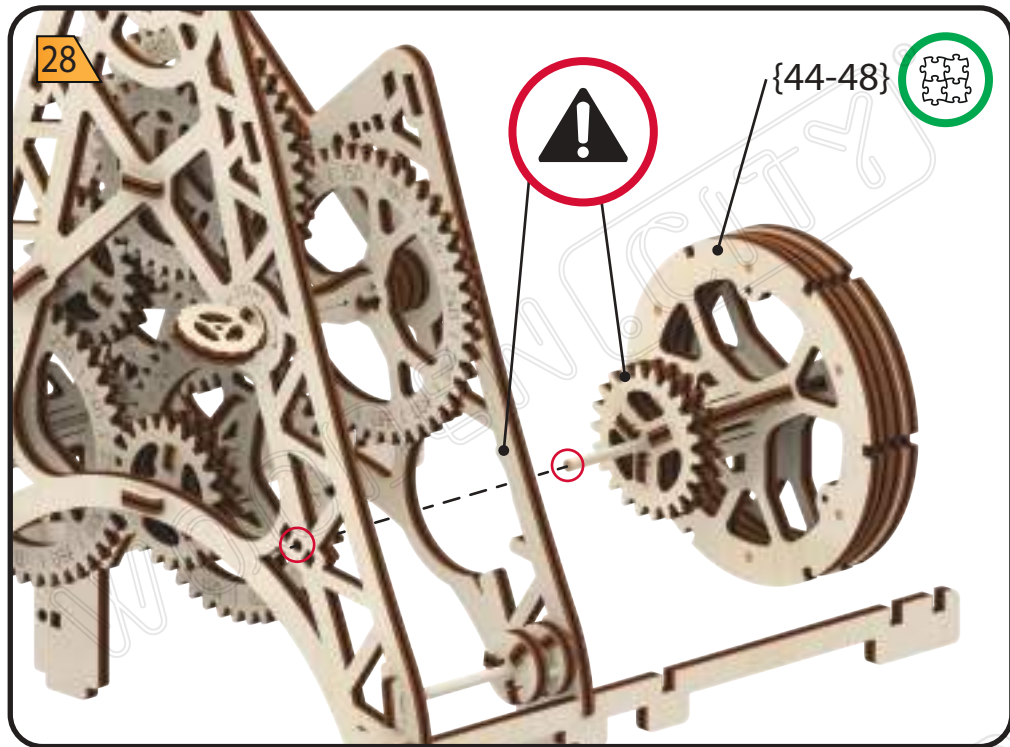

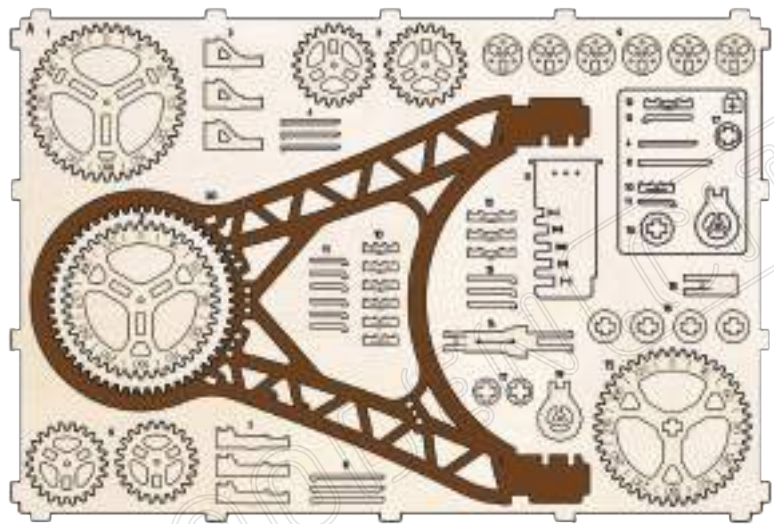

1

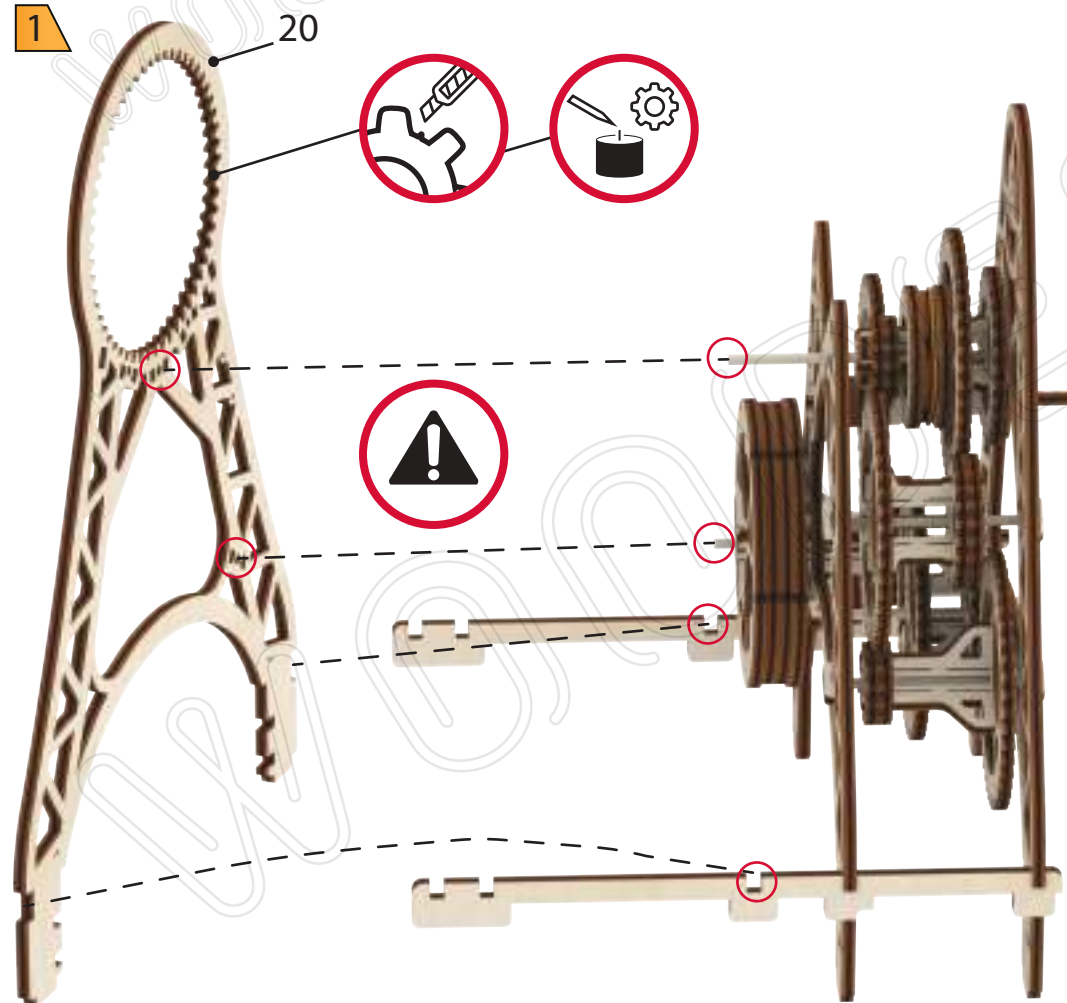

2

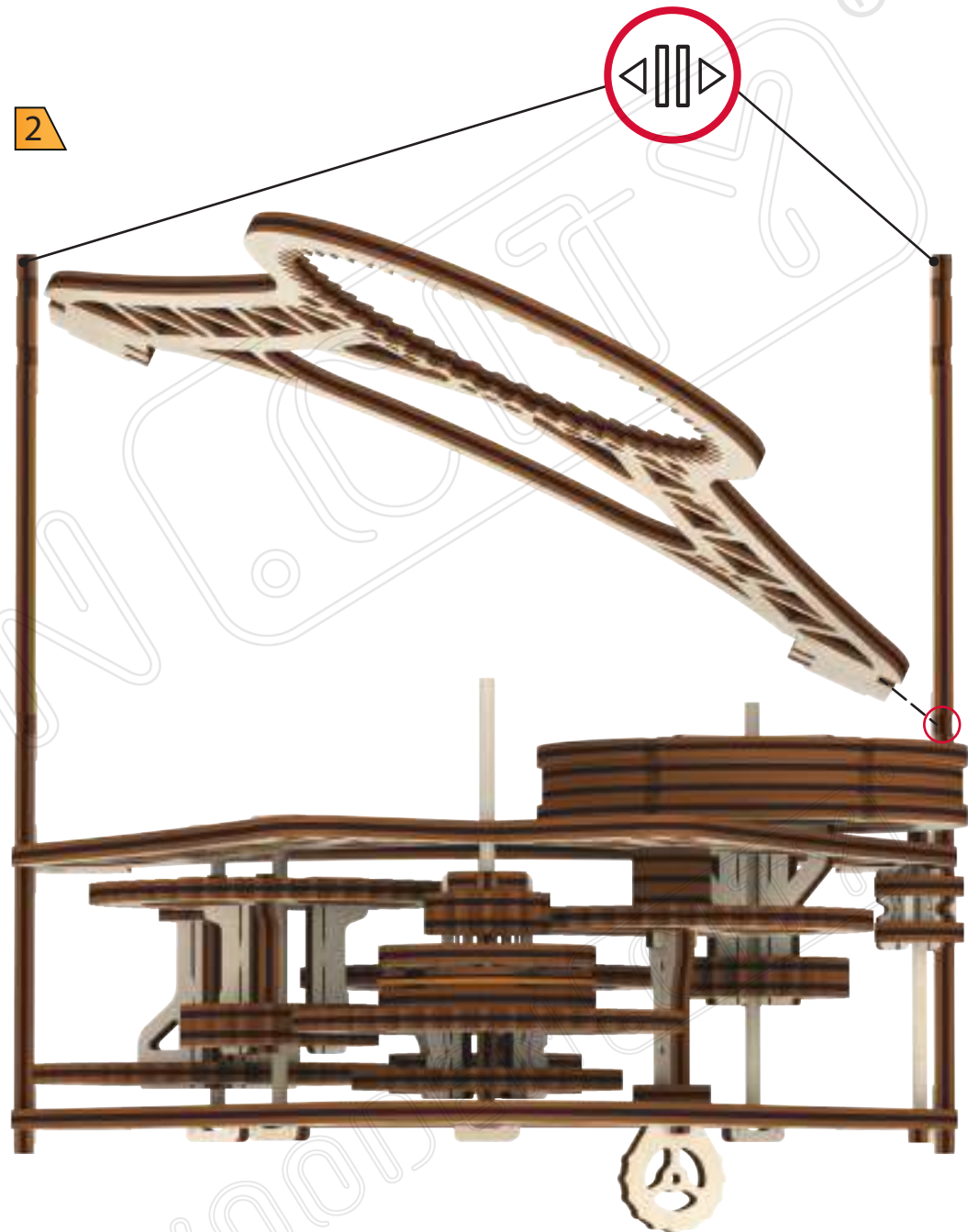

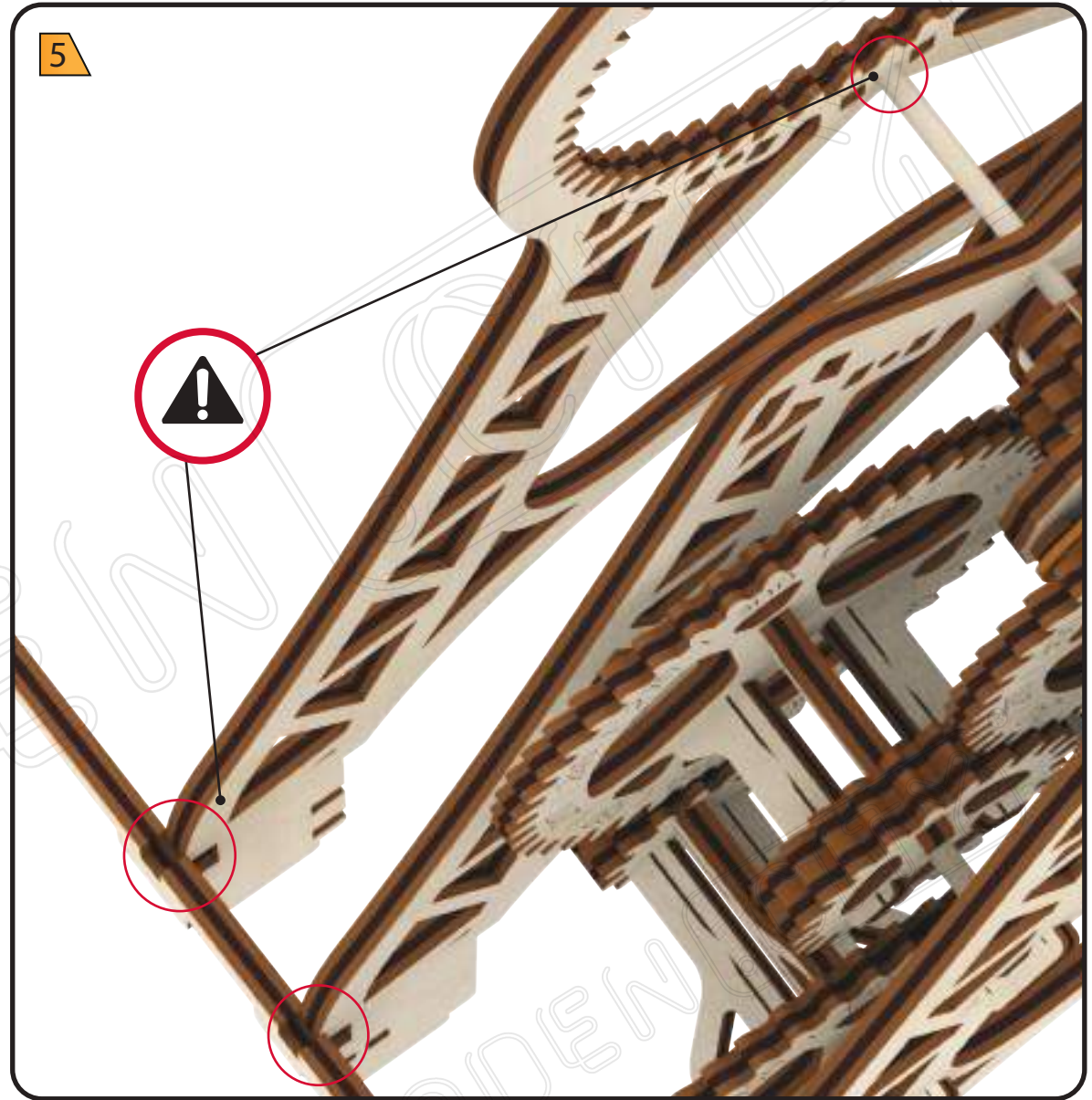
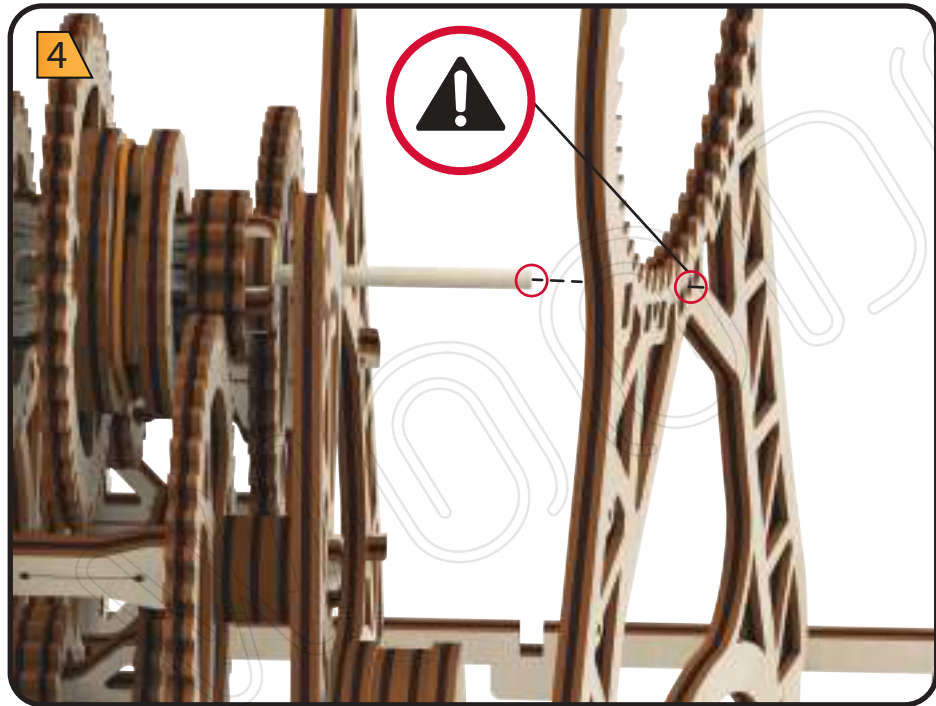
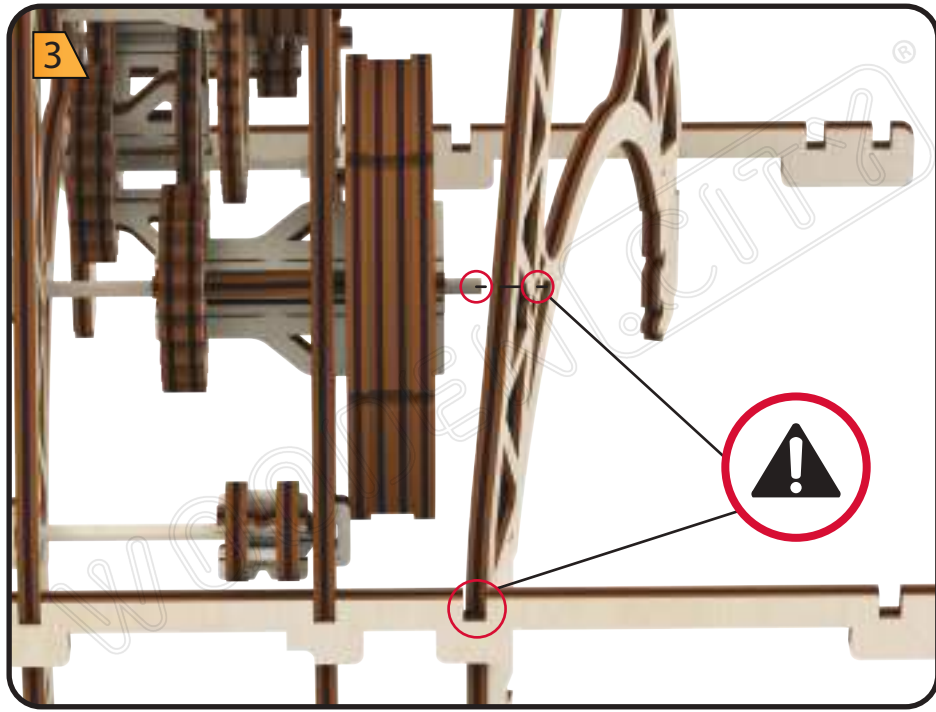

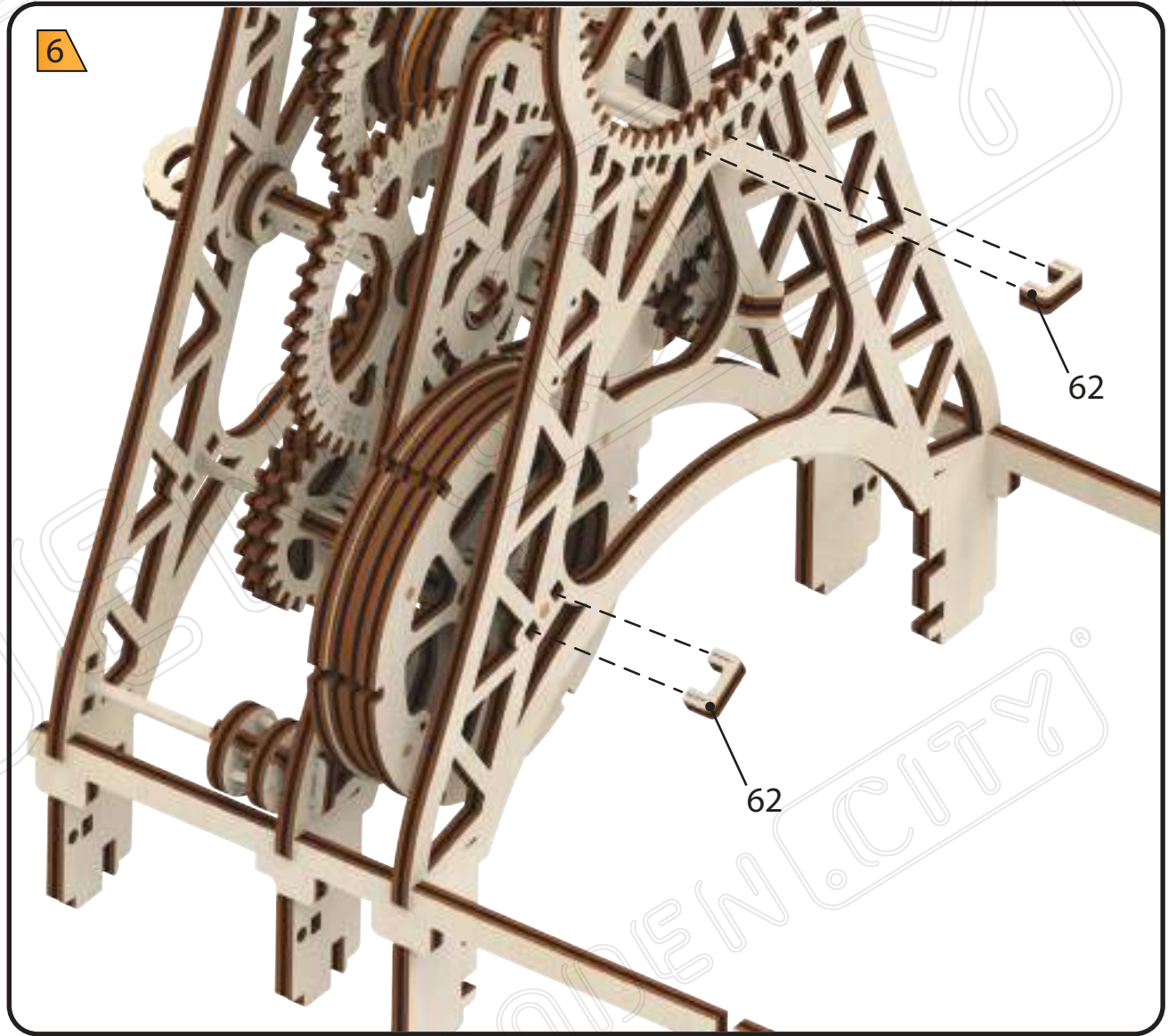
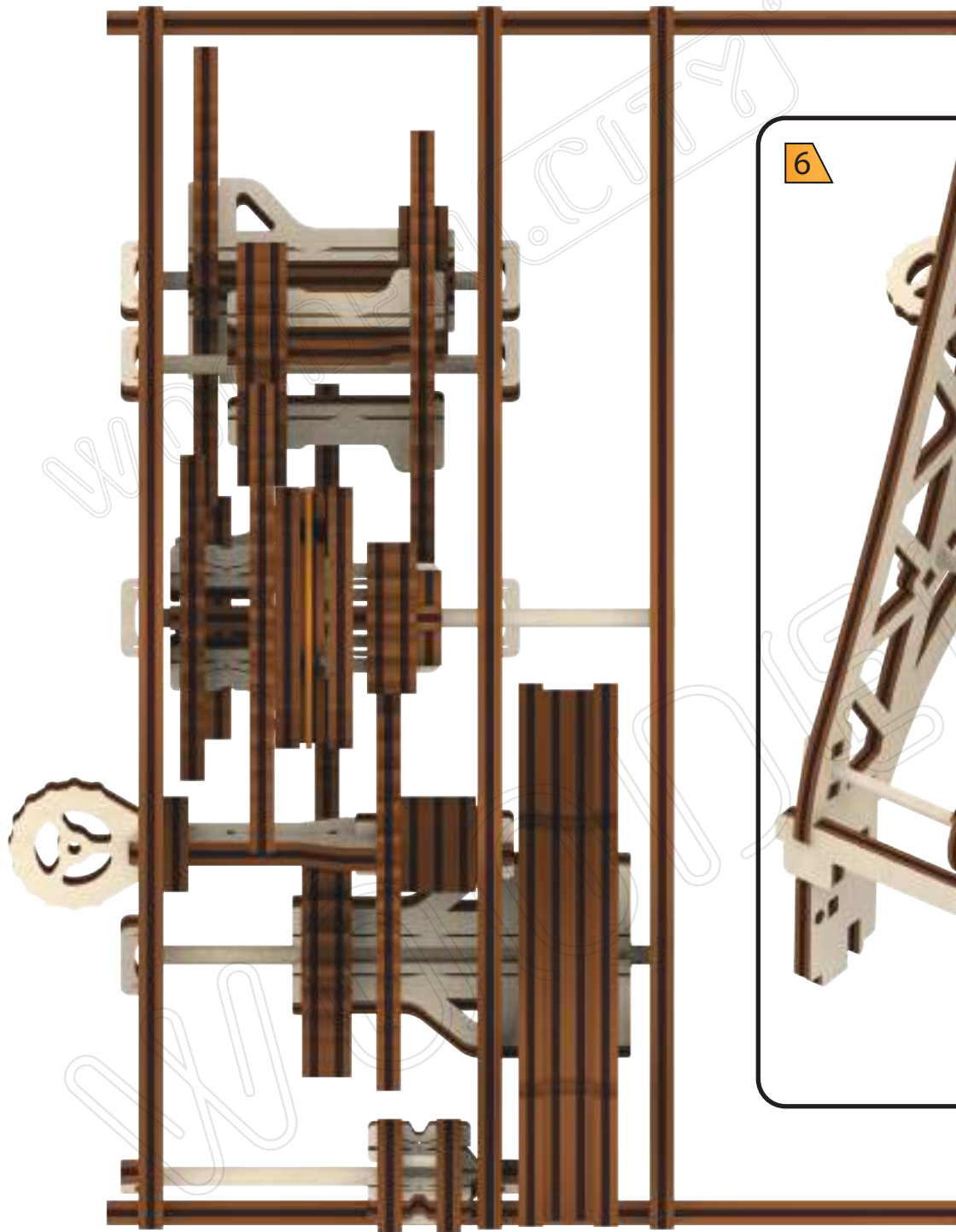

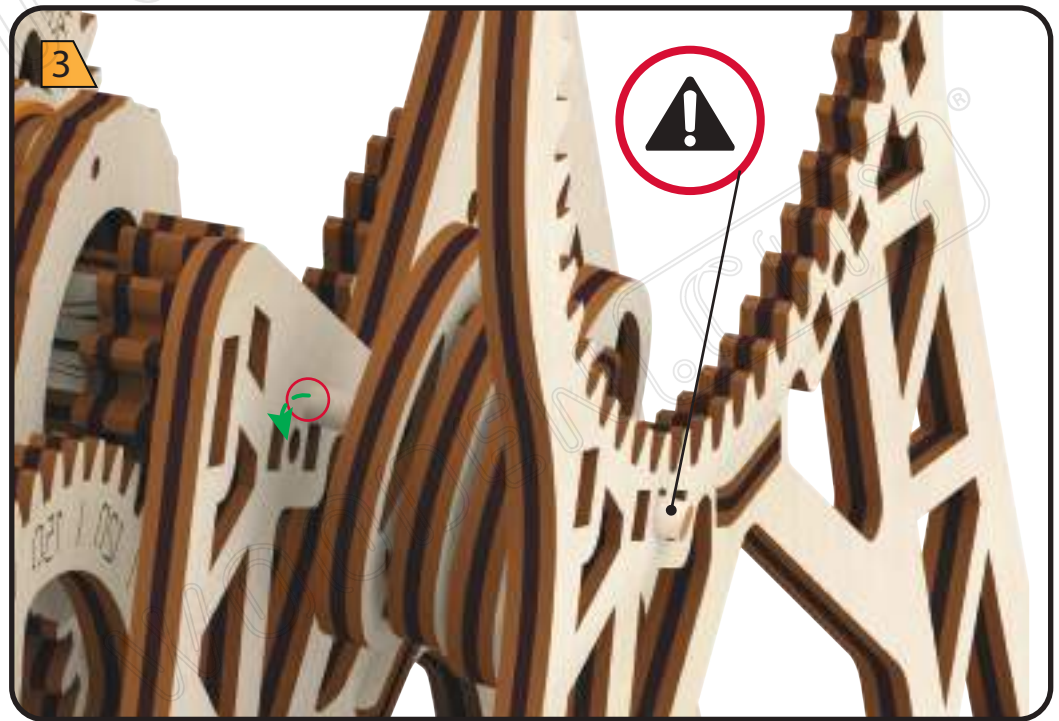
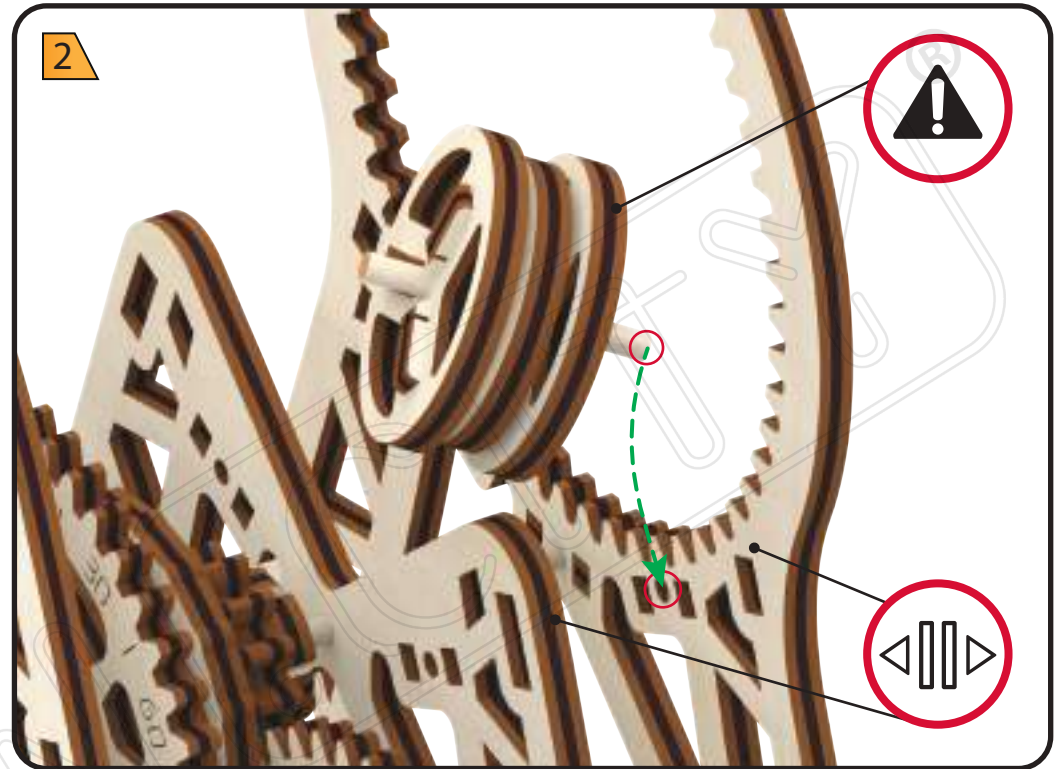
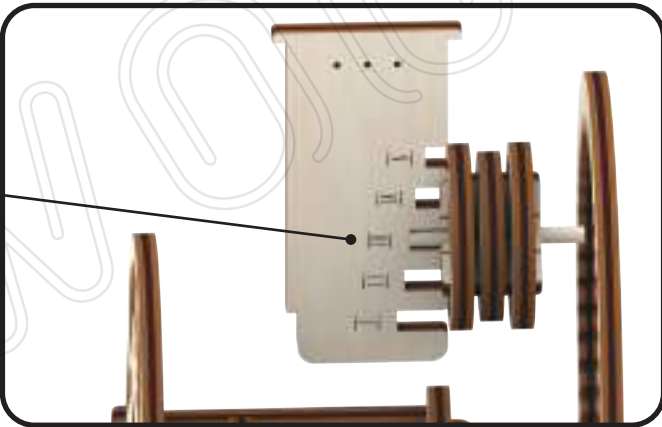
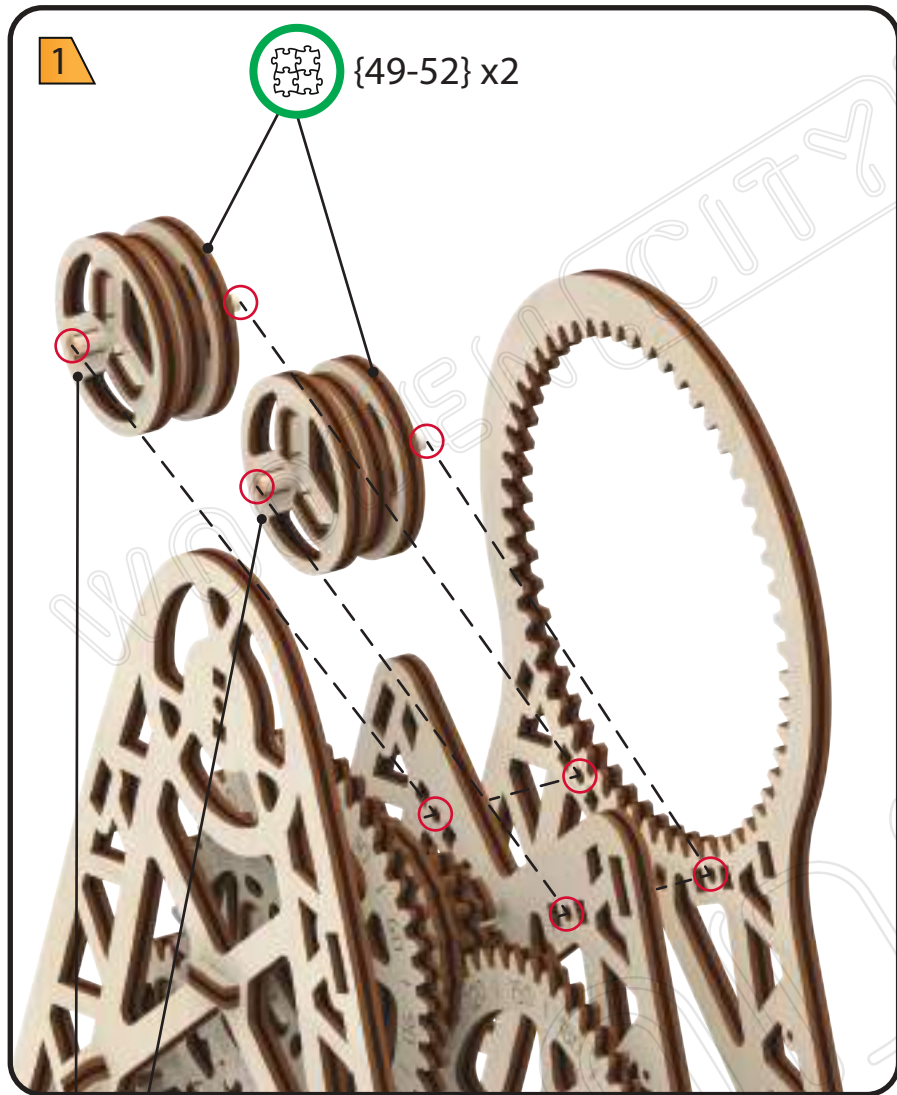

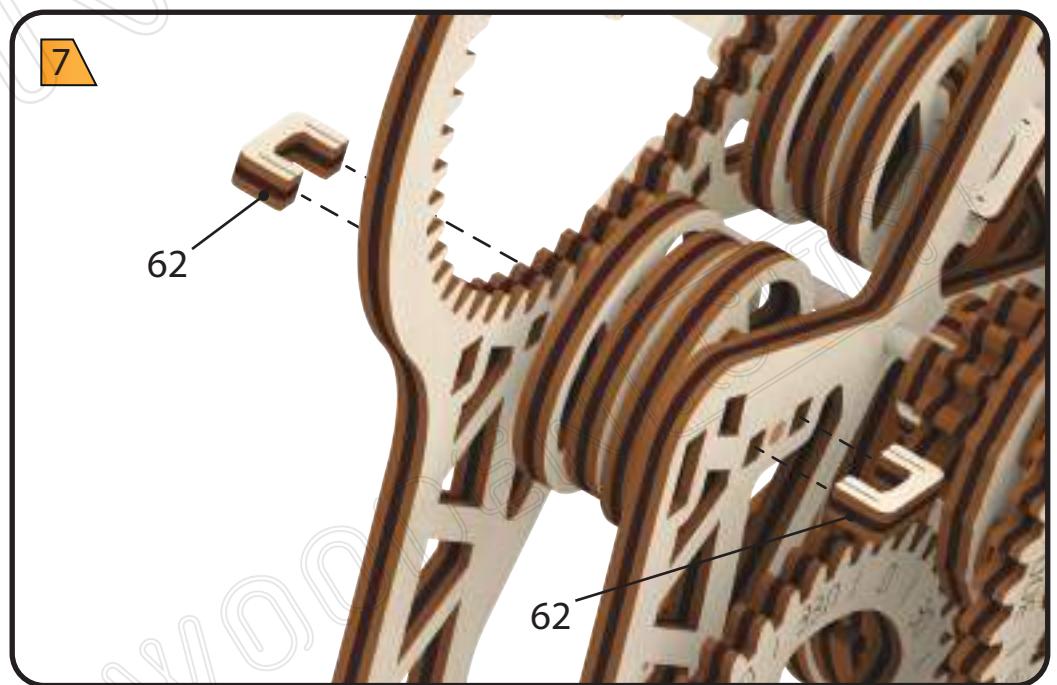
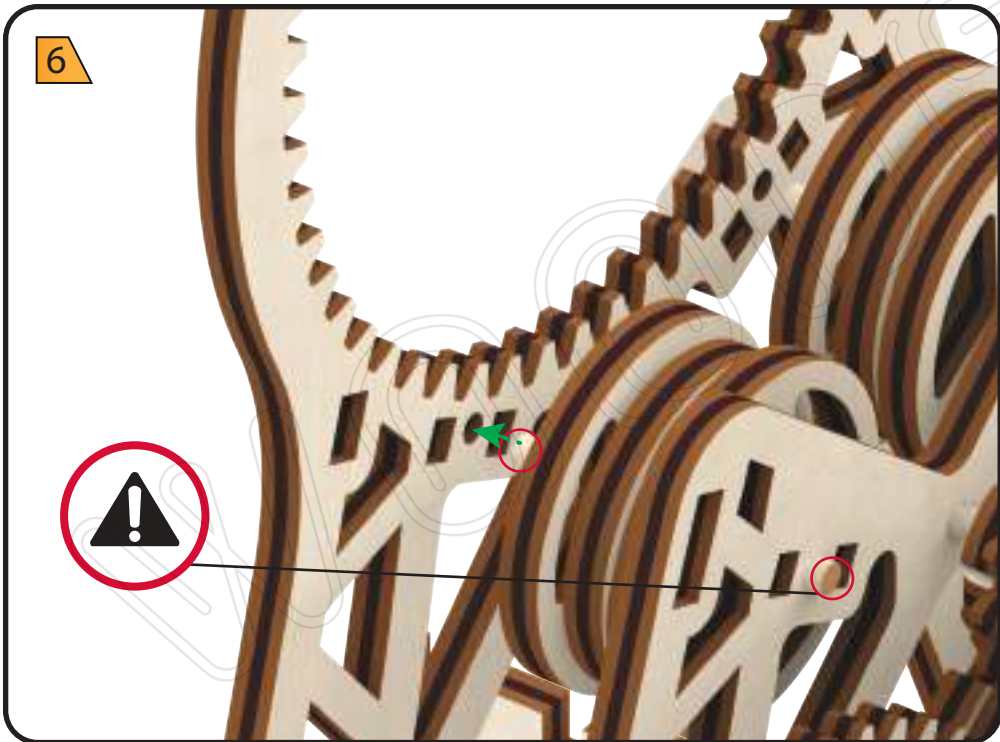
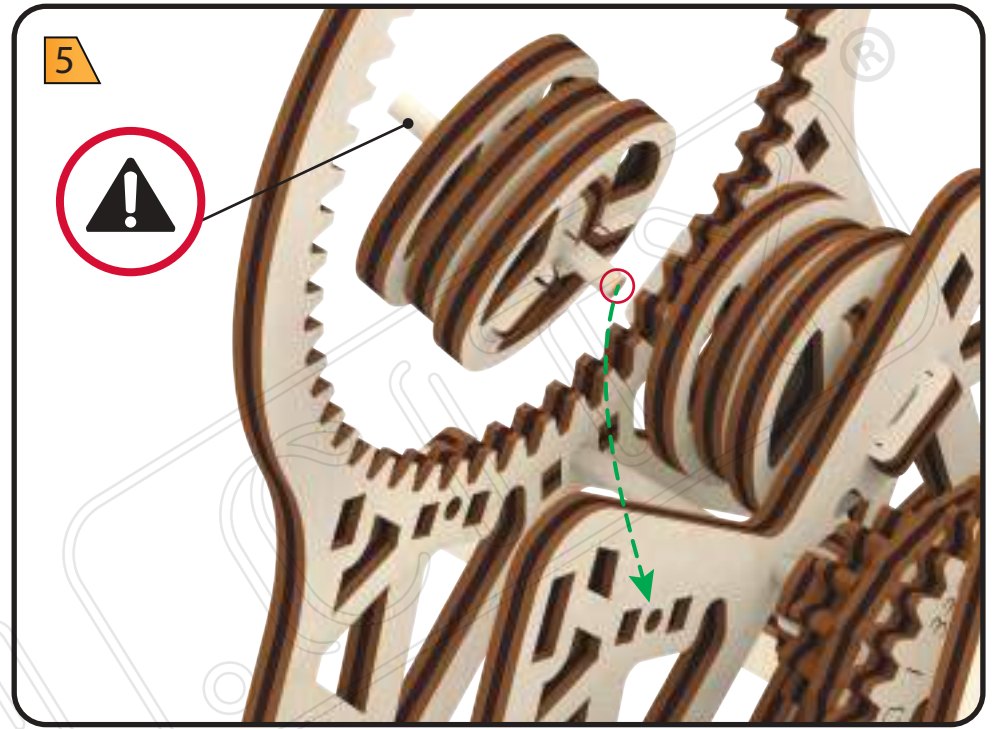
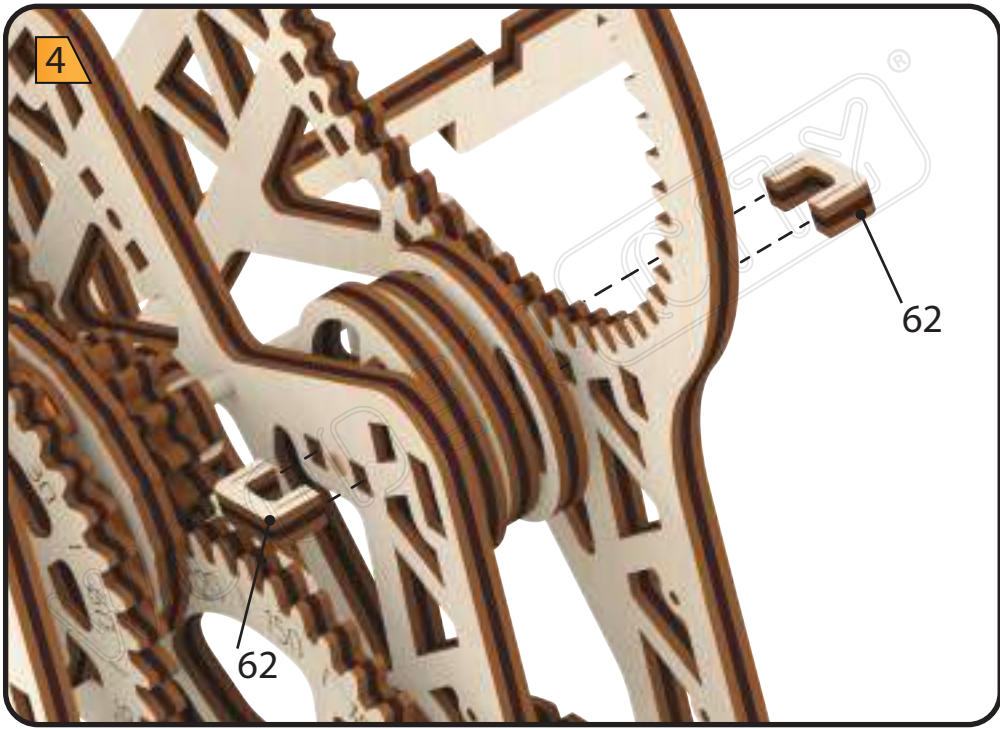

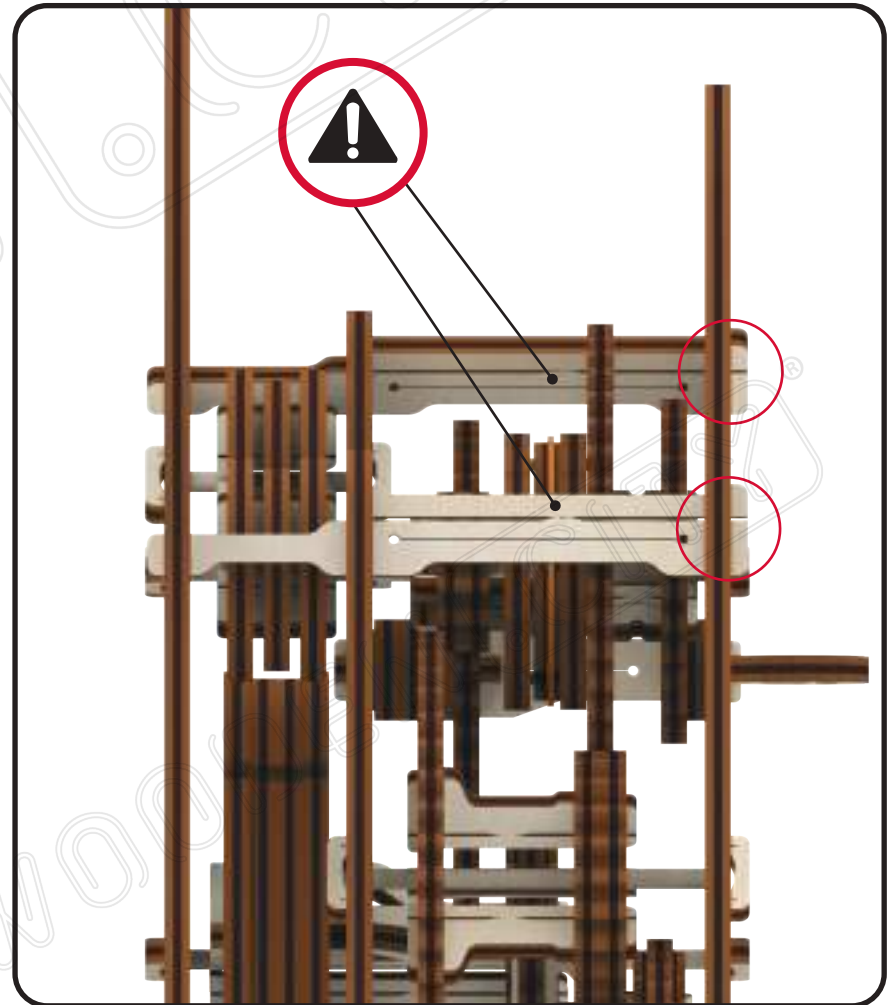
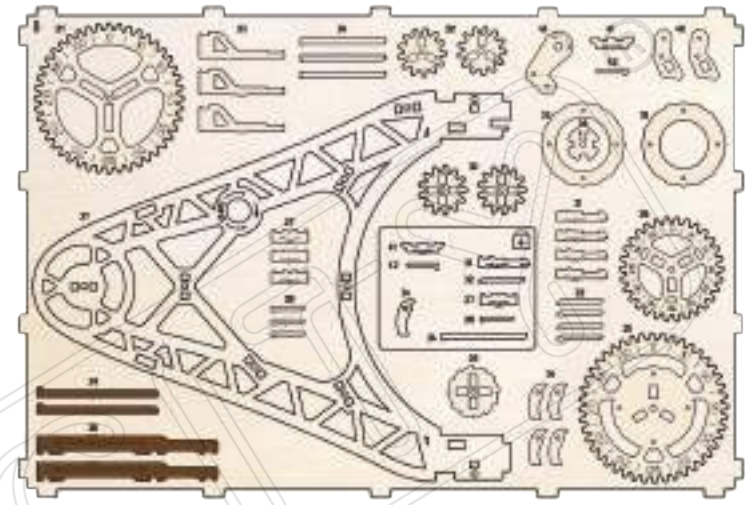
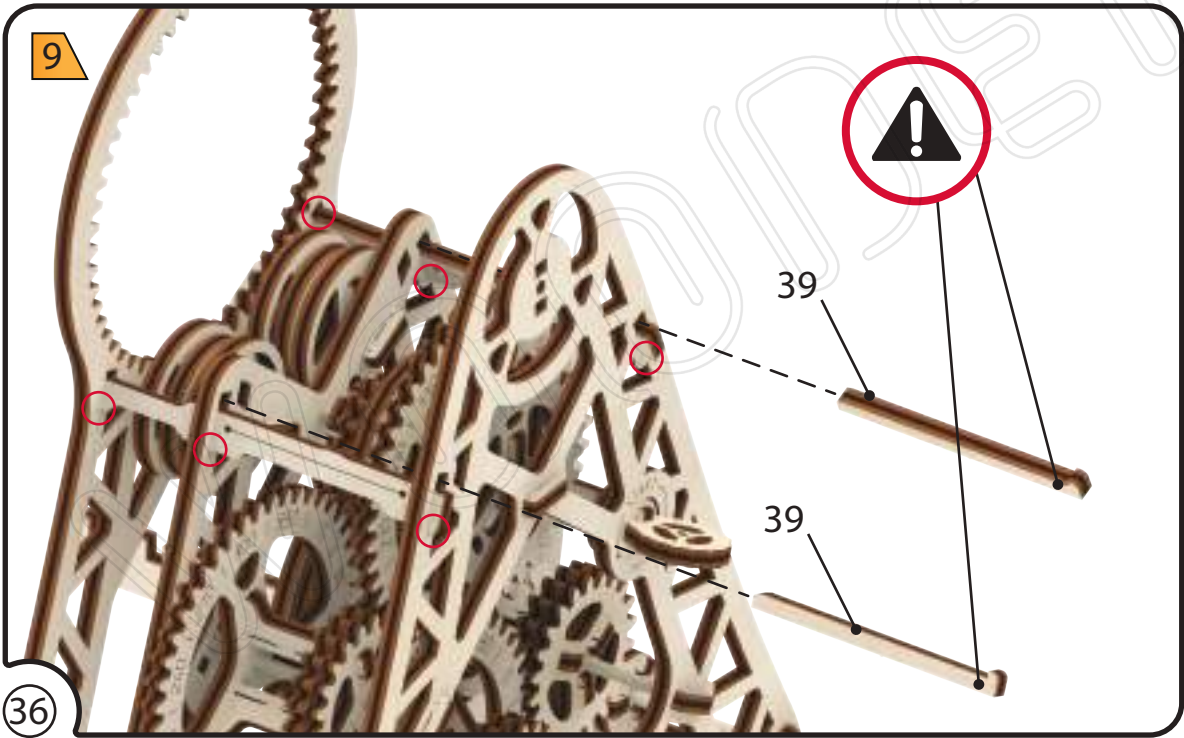
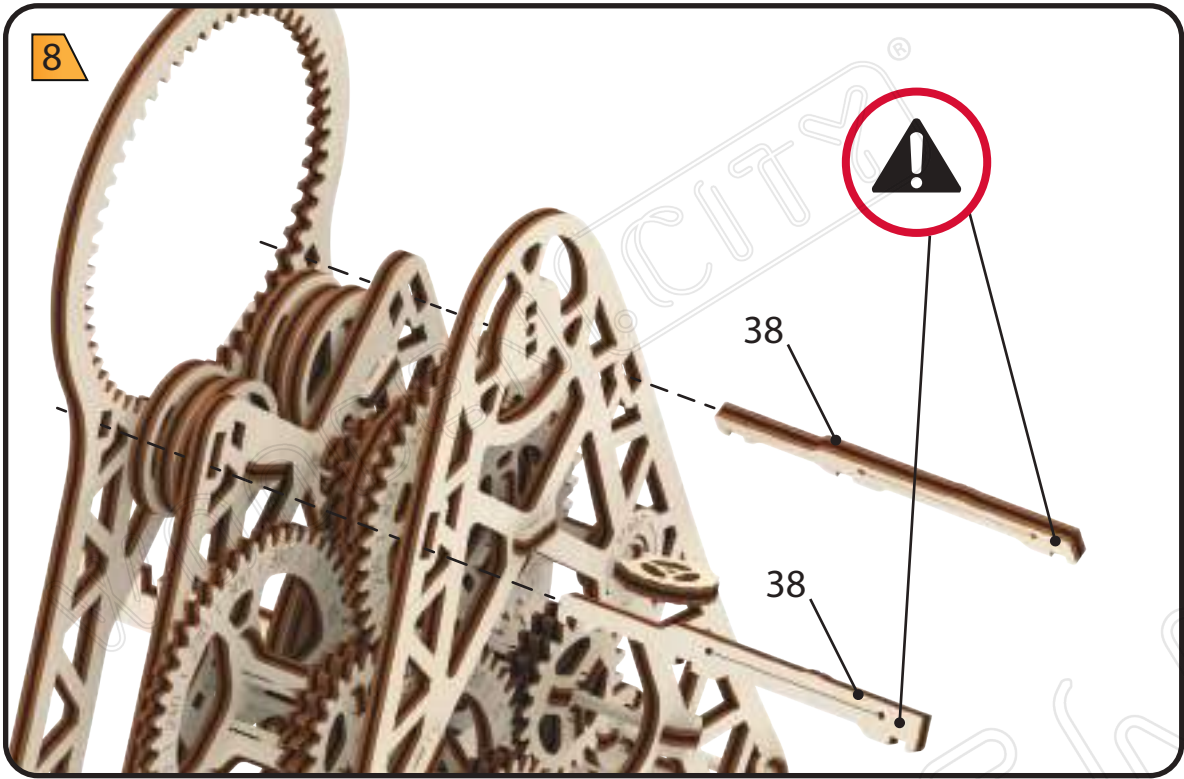

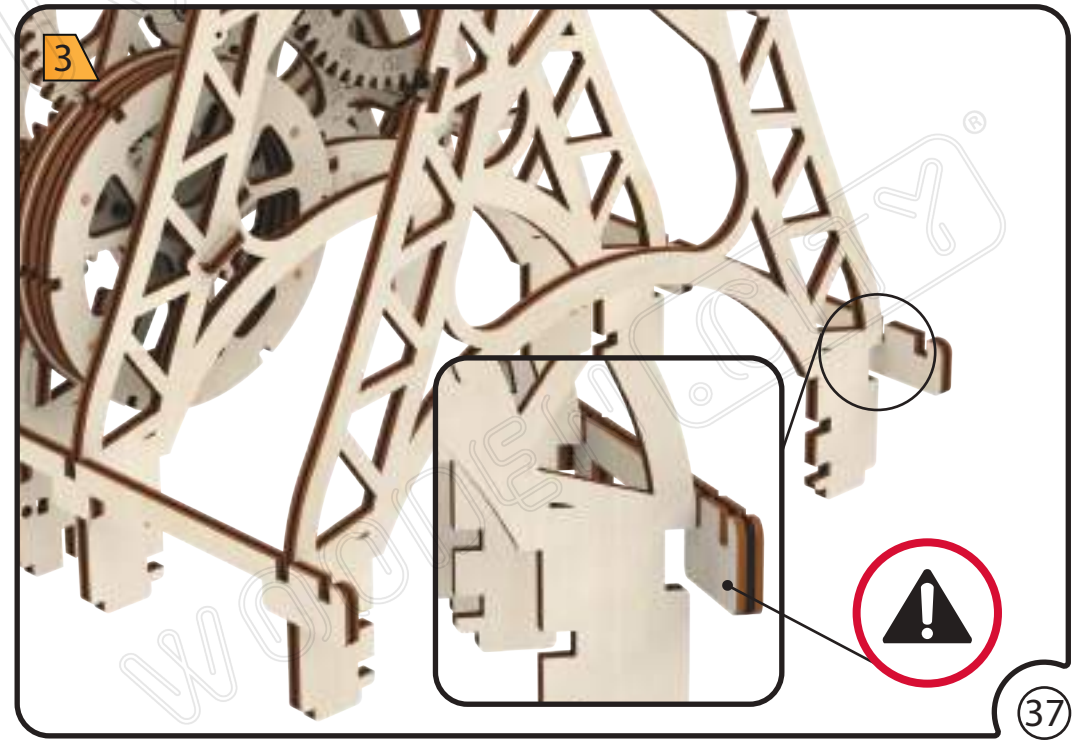
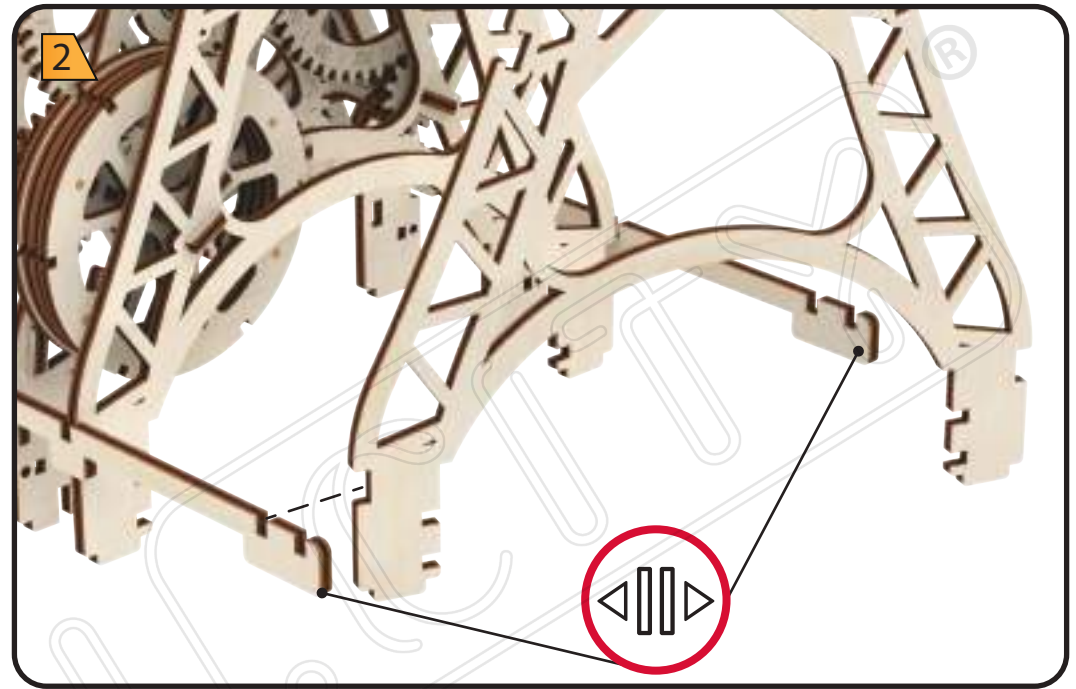
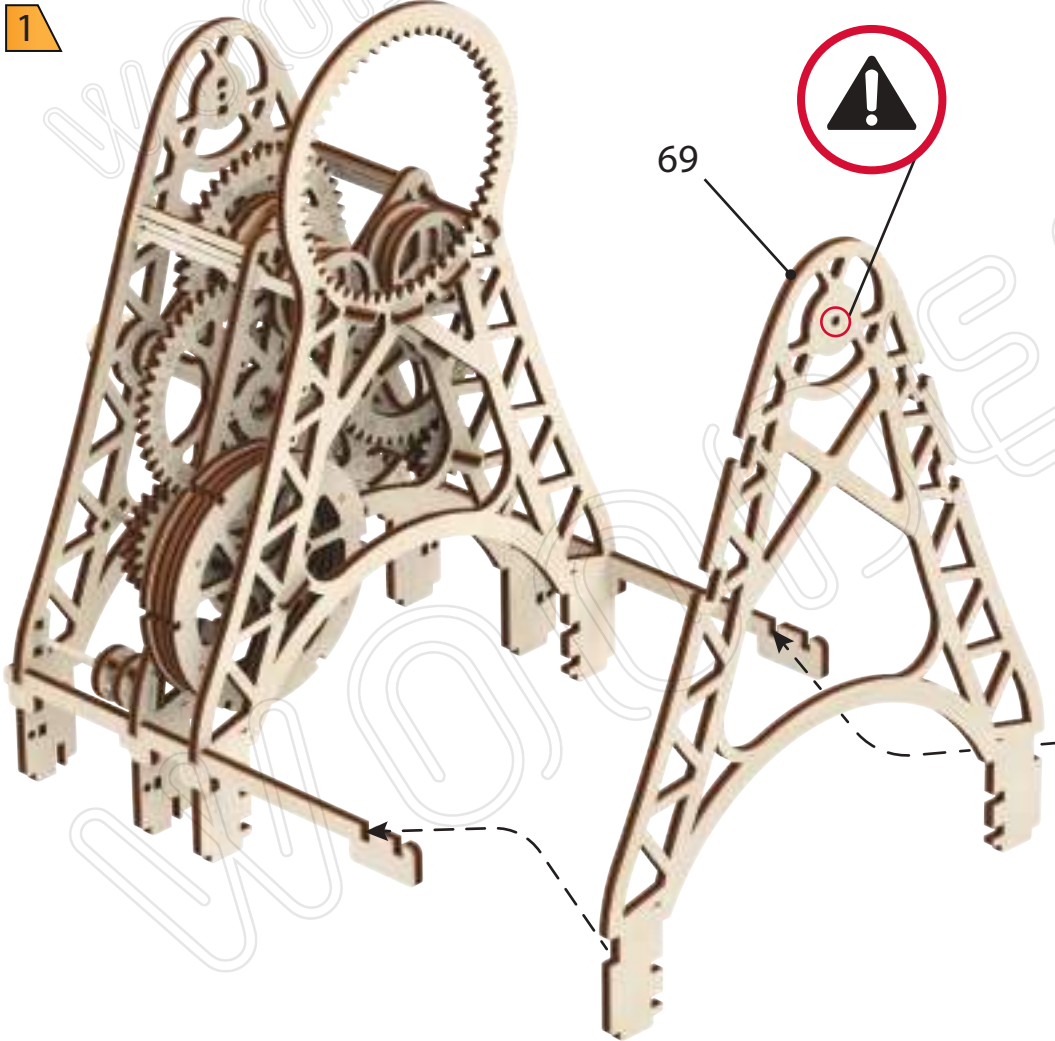
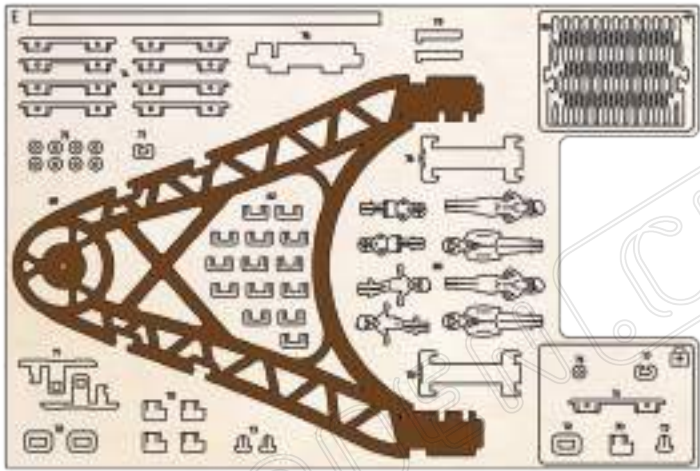

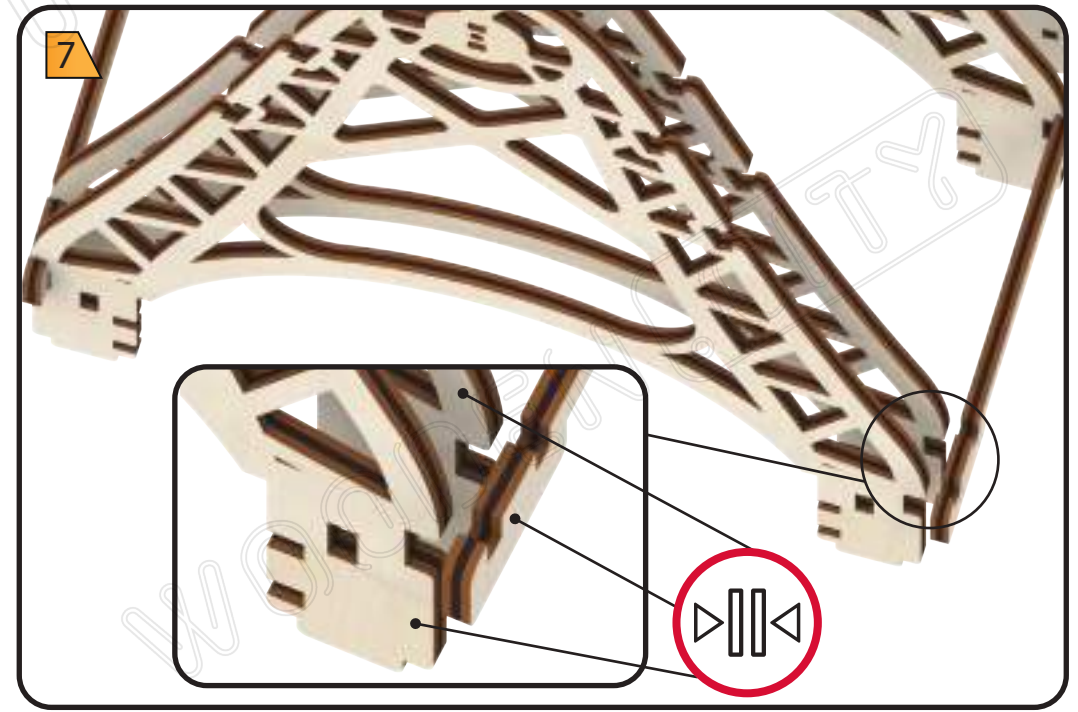
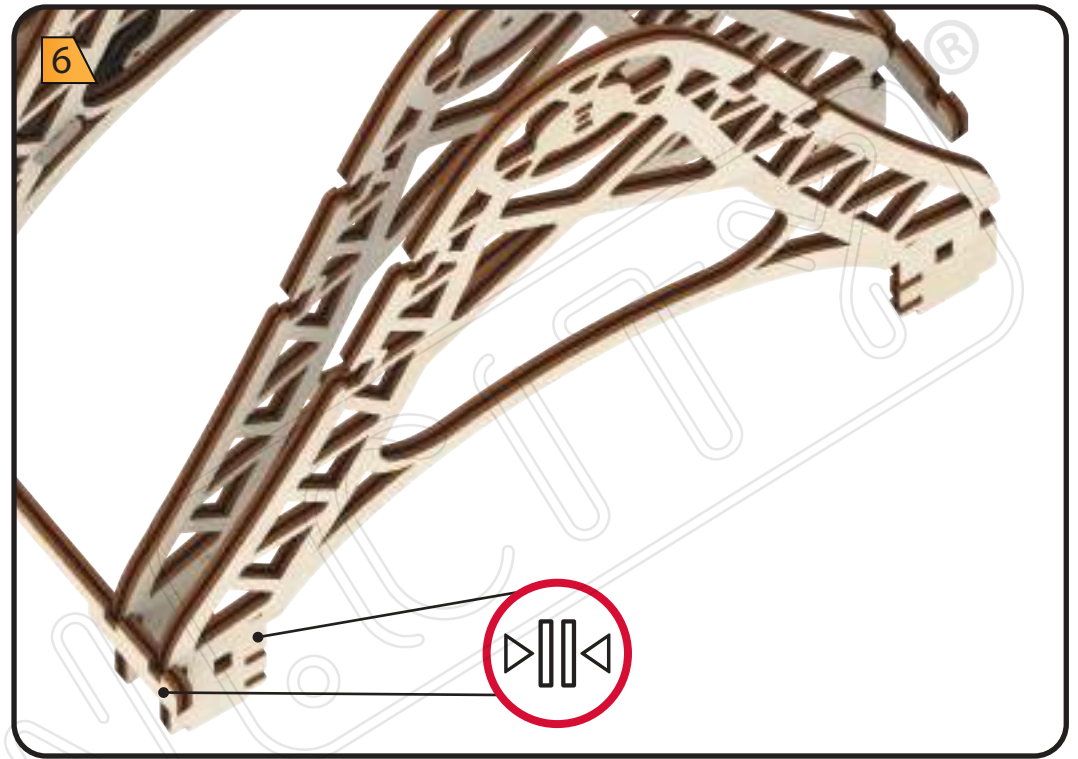
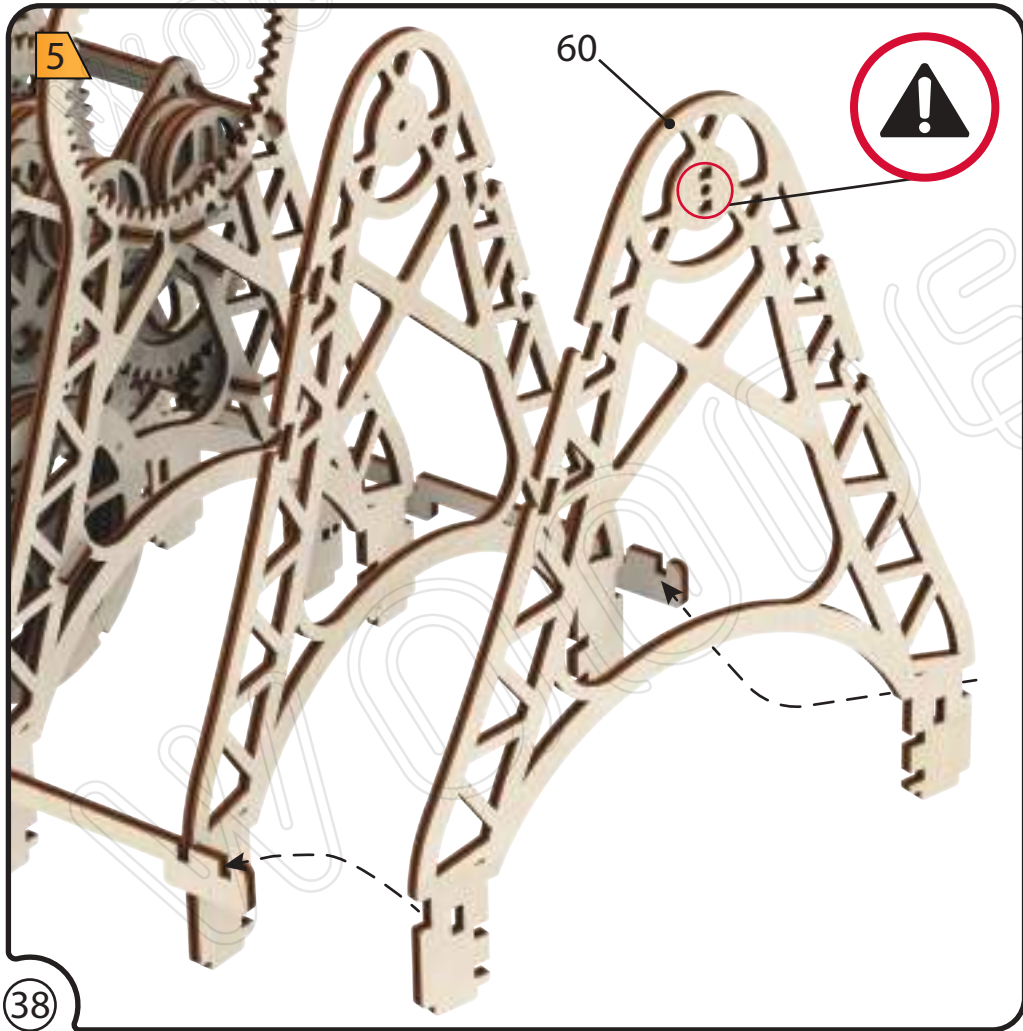
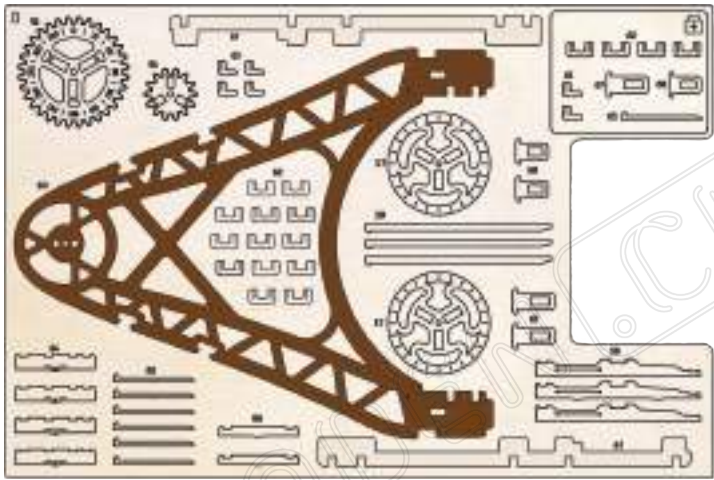

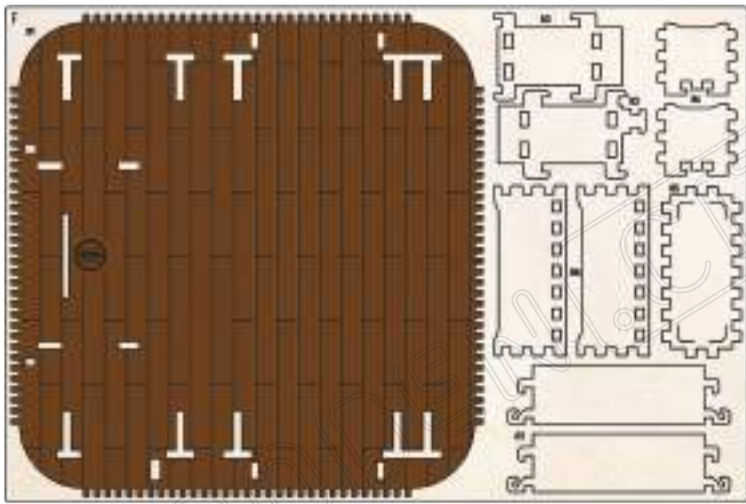

1

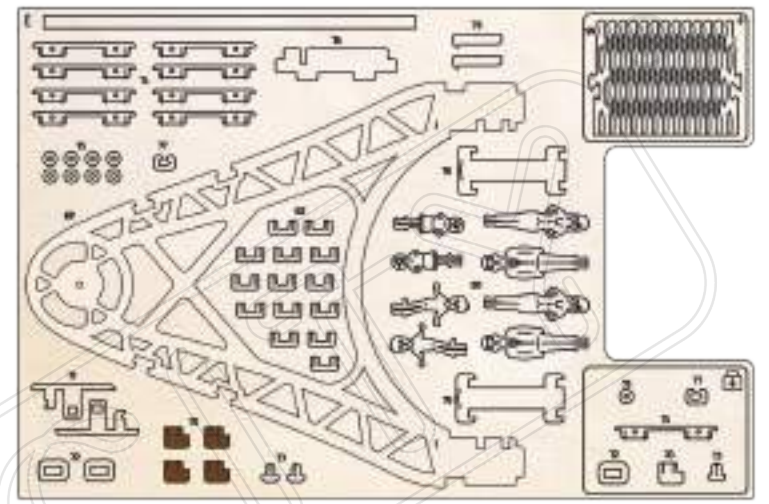
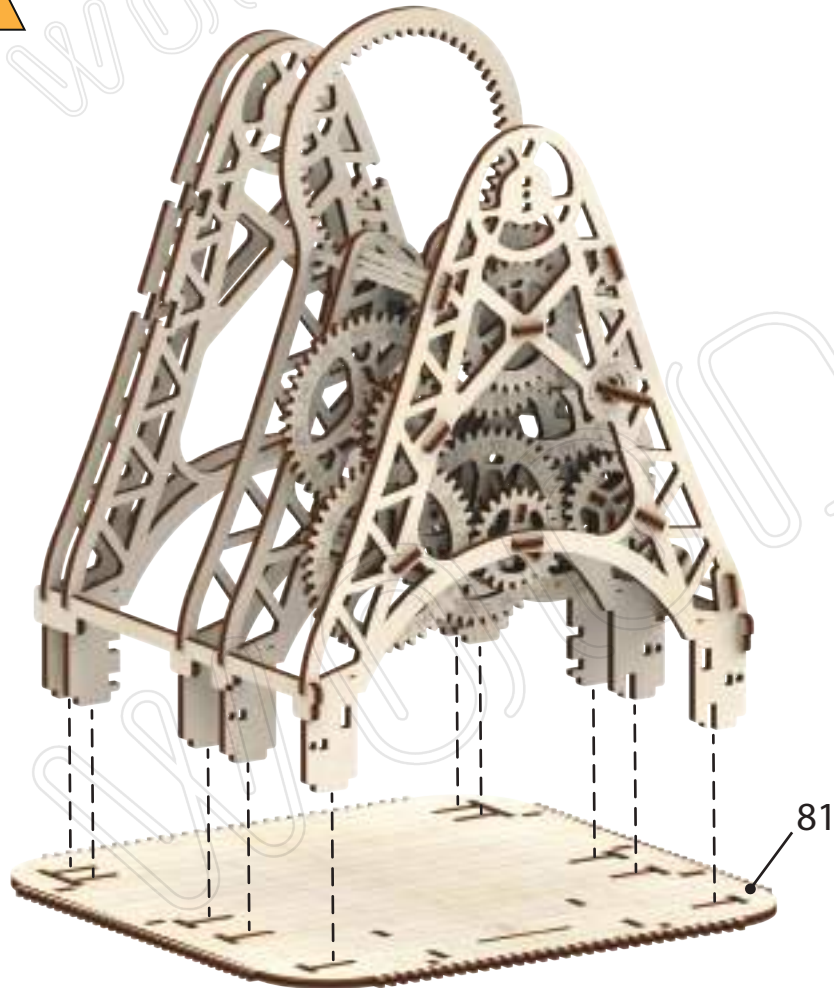

2

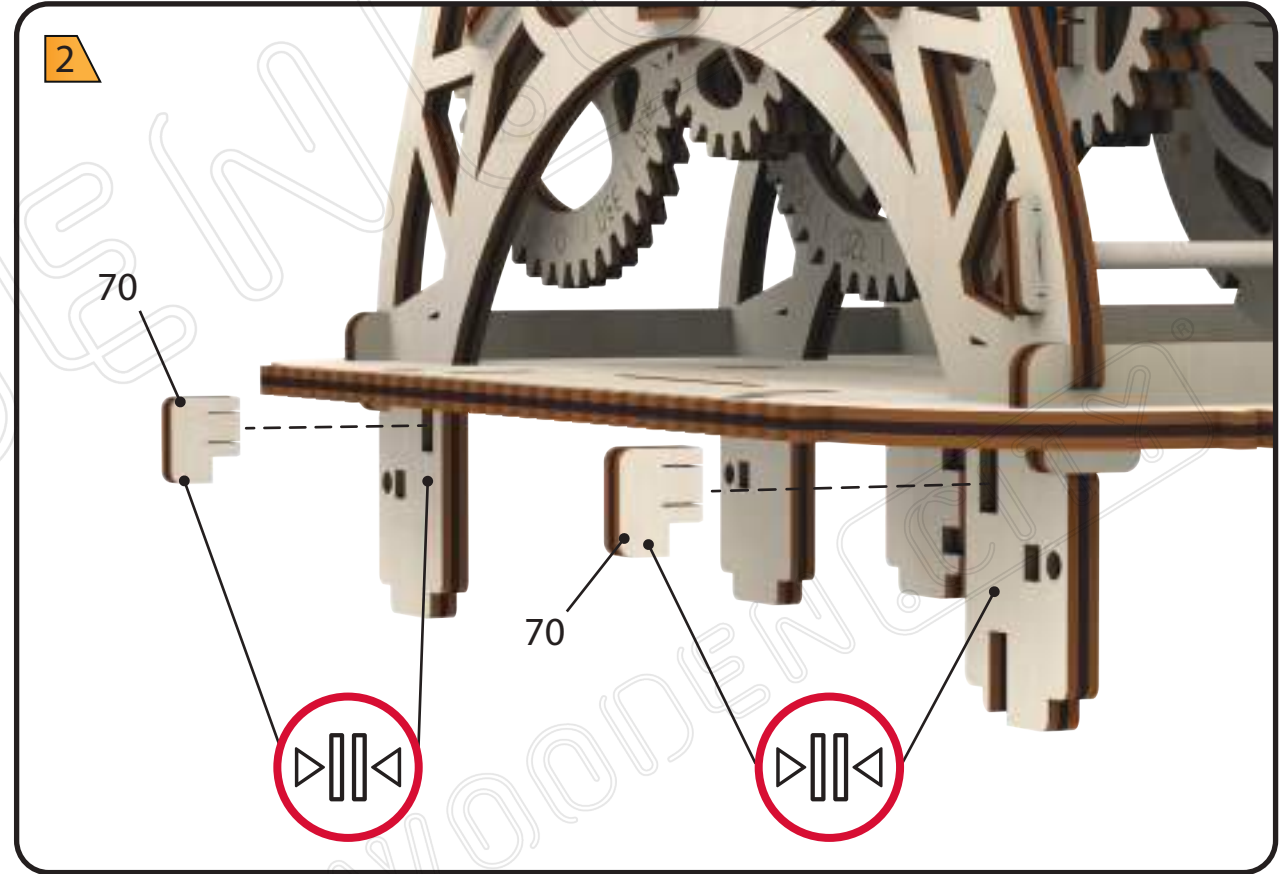

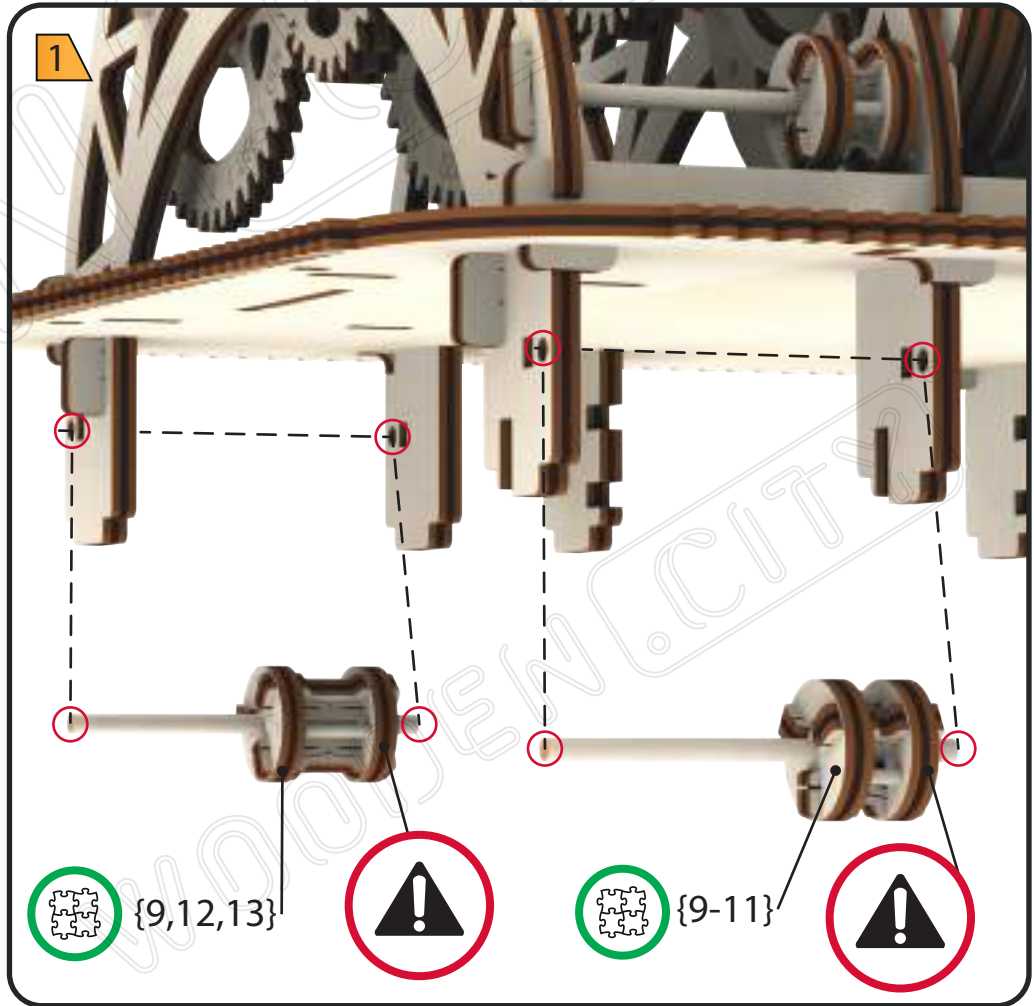
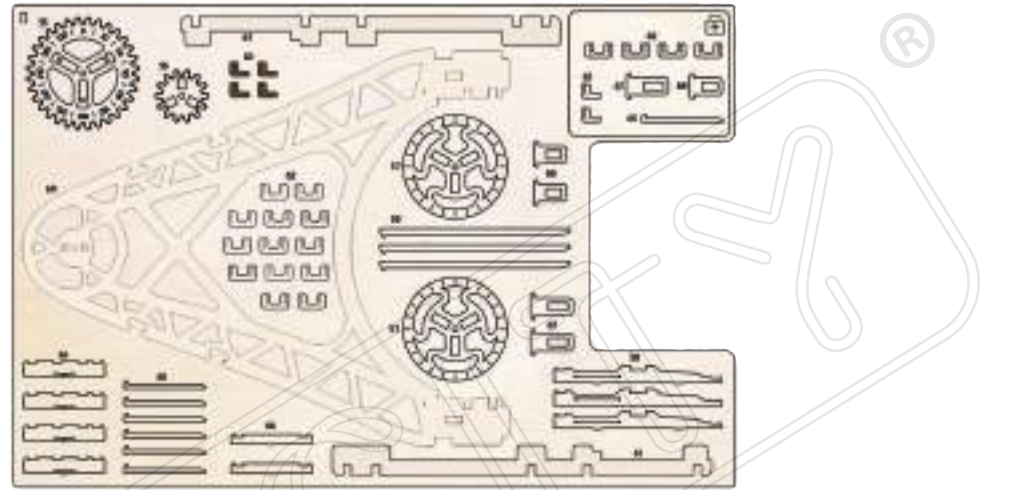
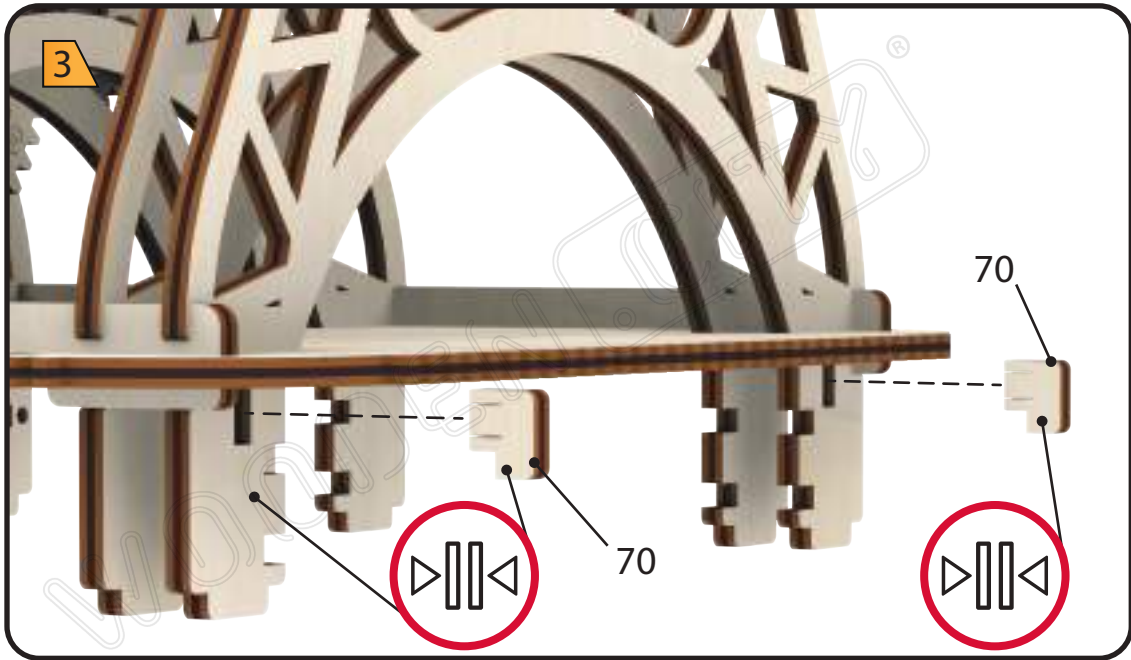

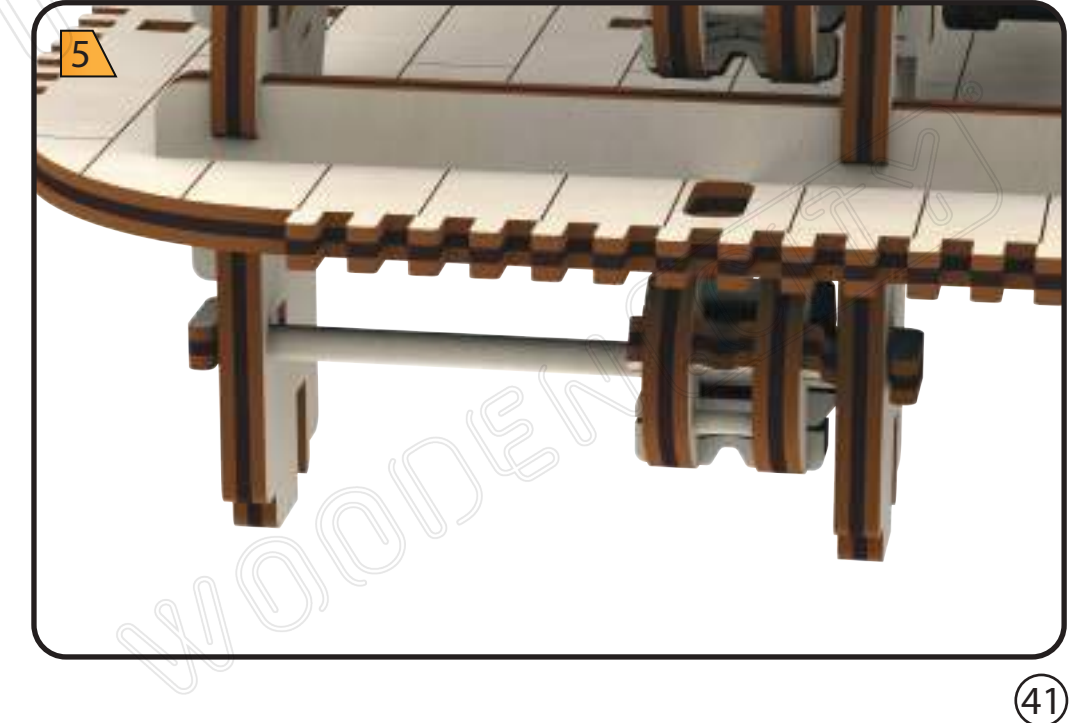
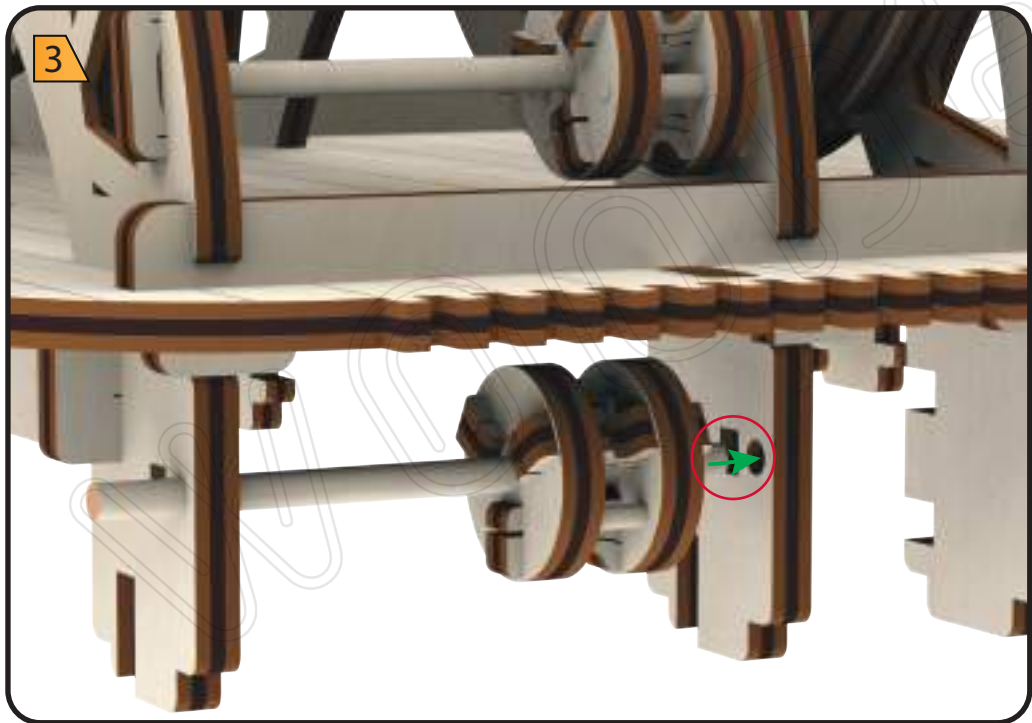
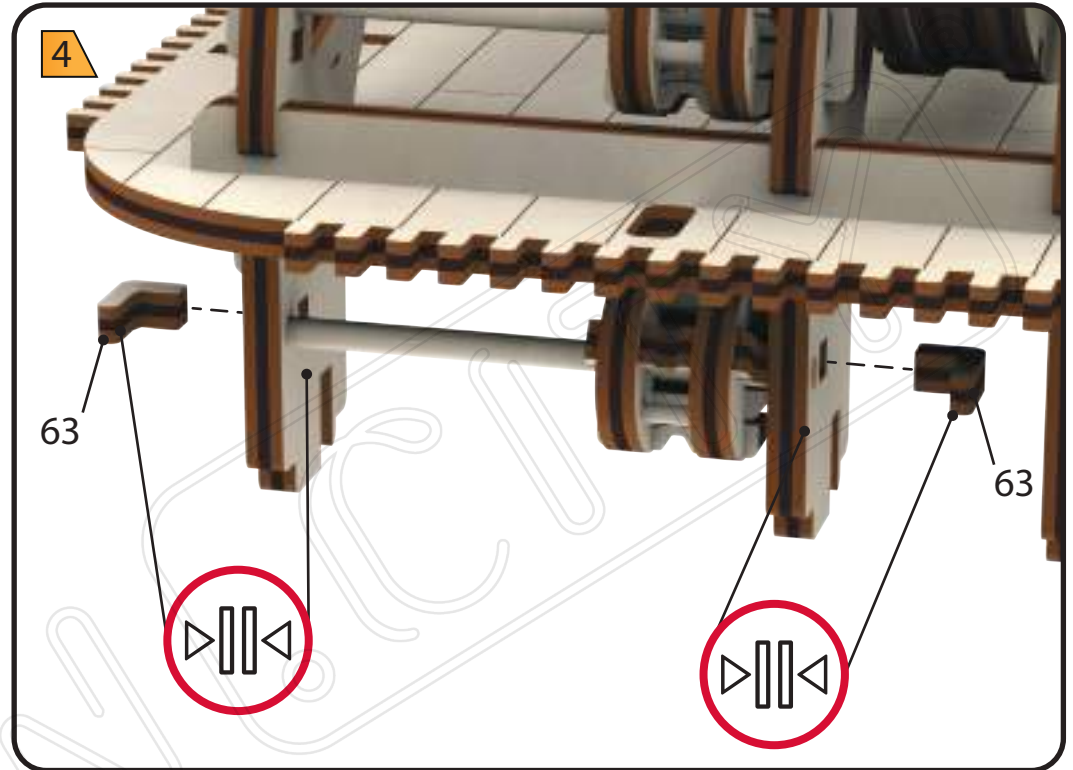
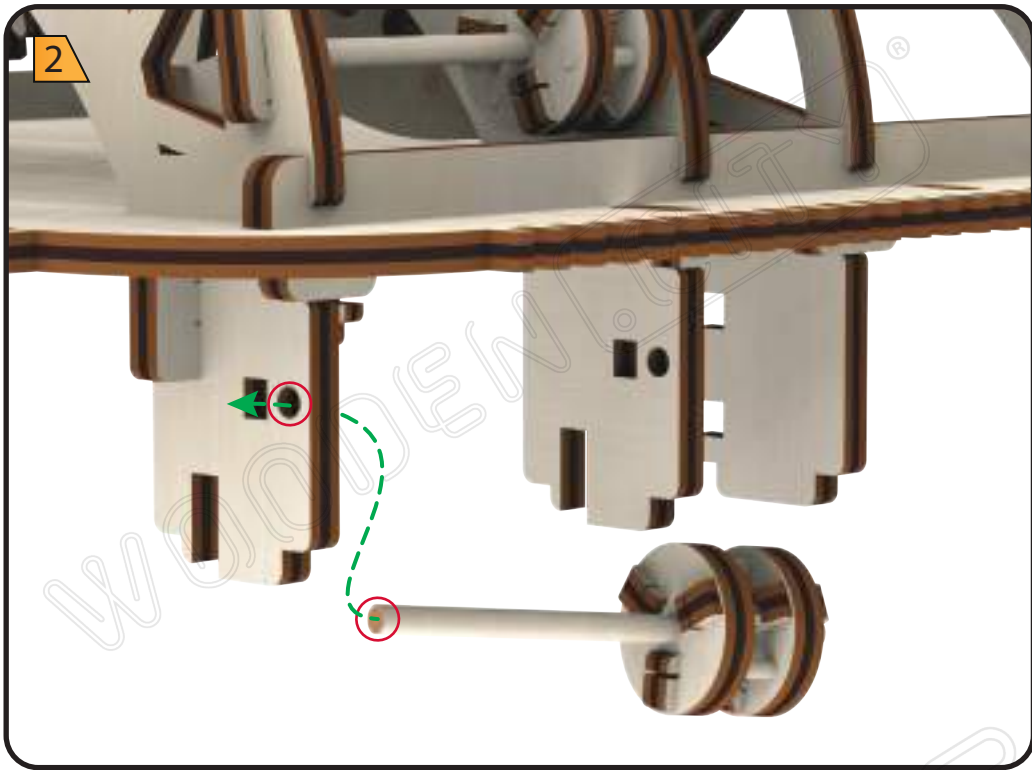

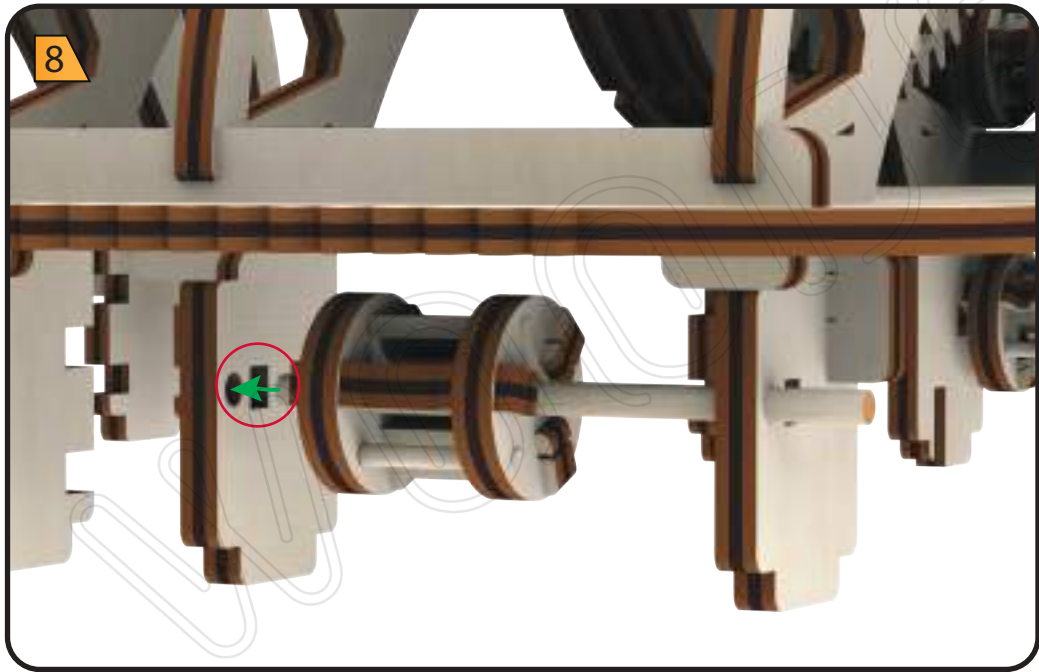
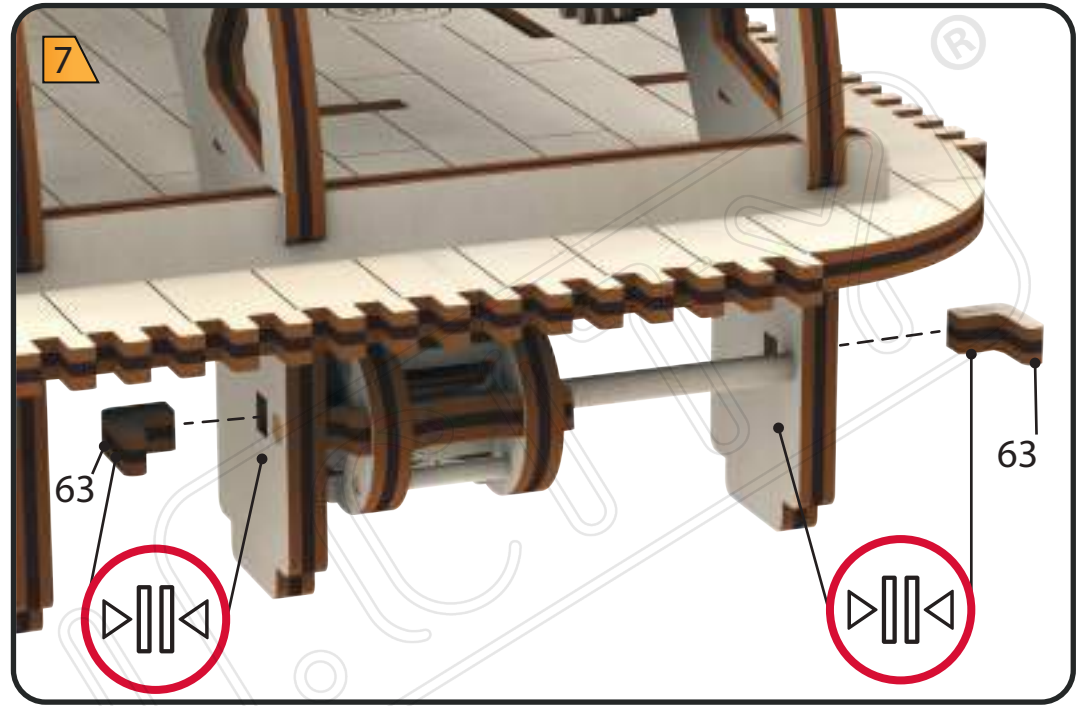
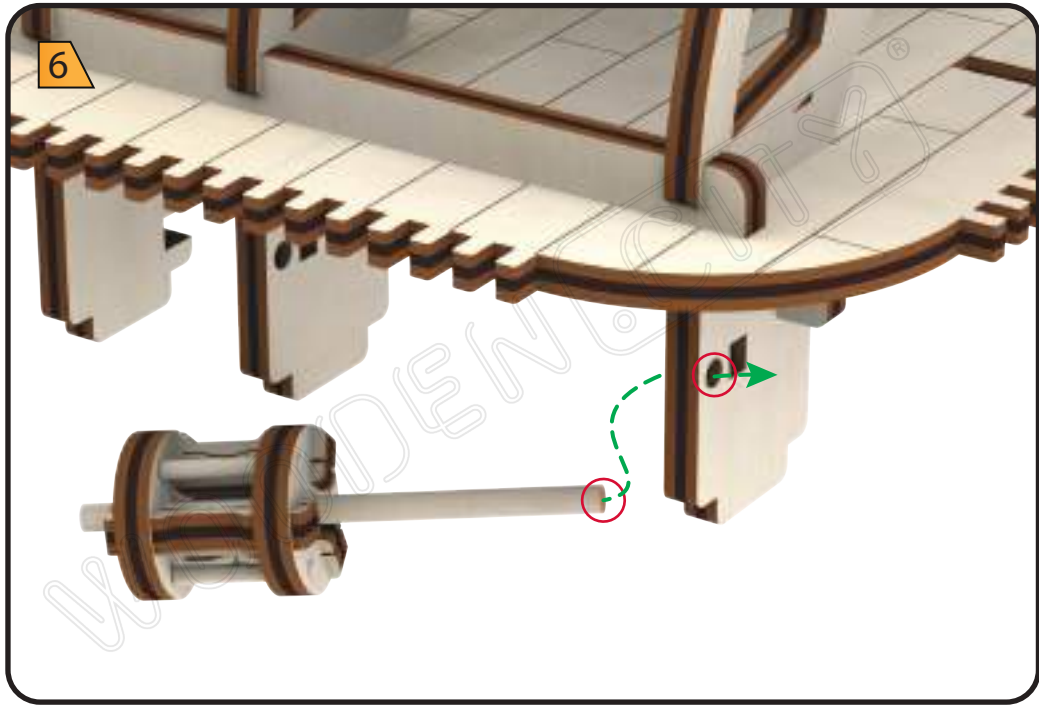

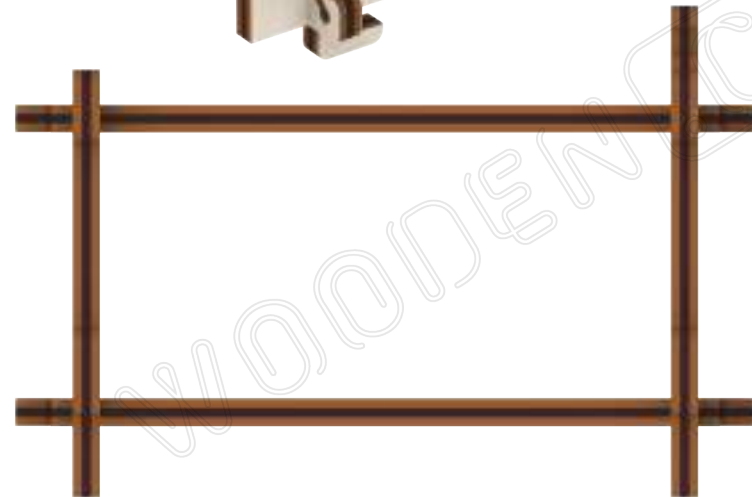
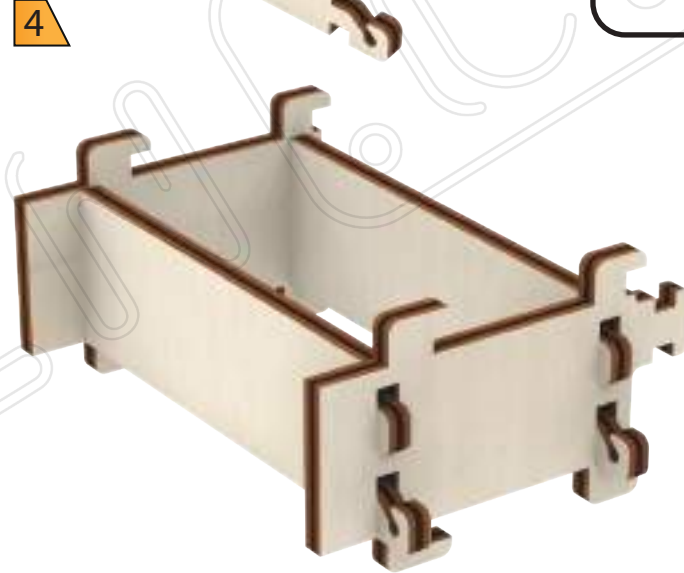
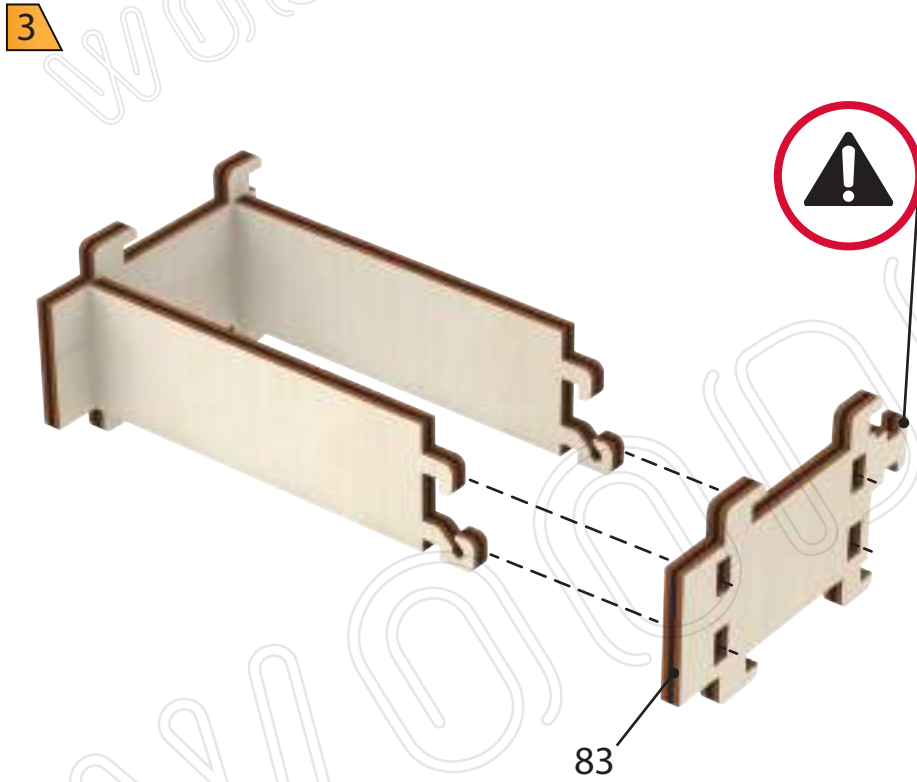
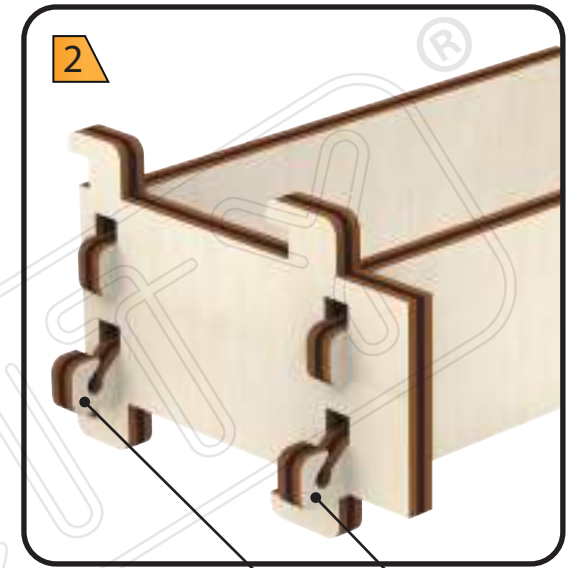
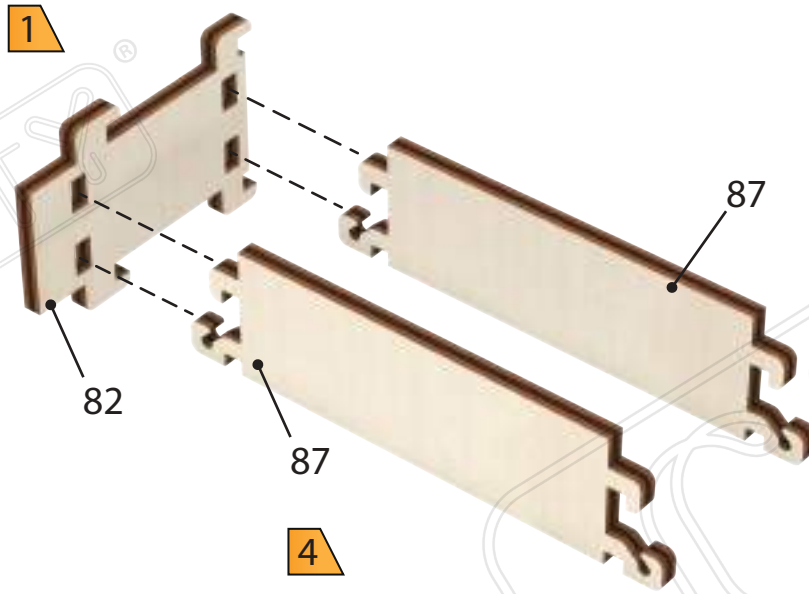
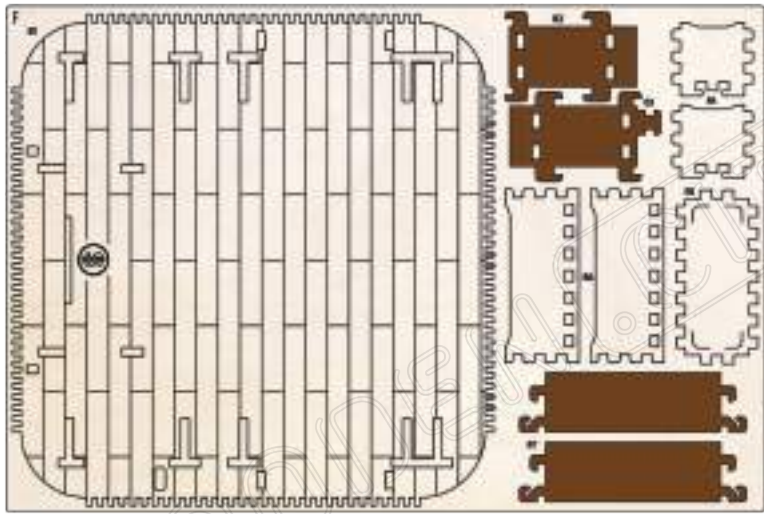

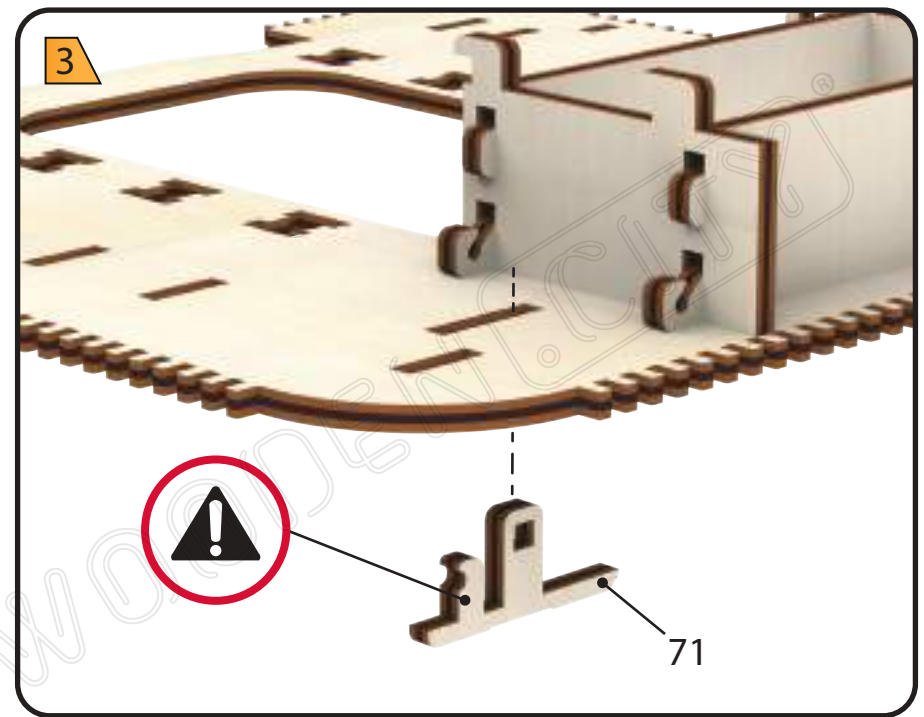
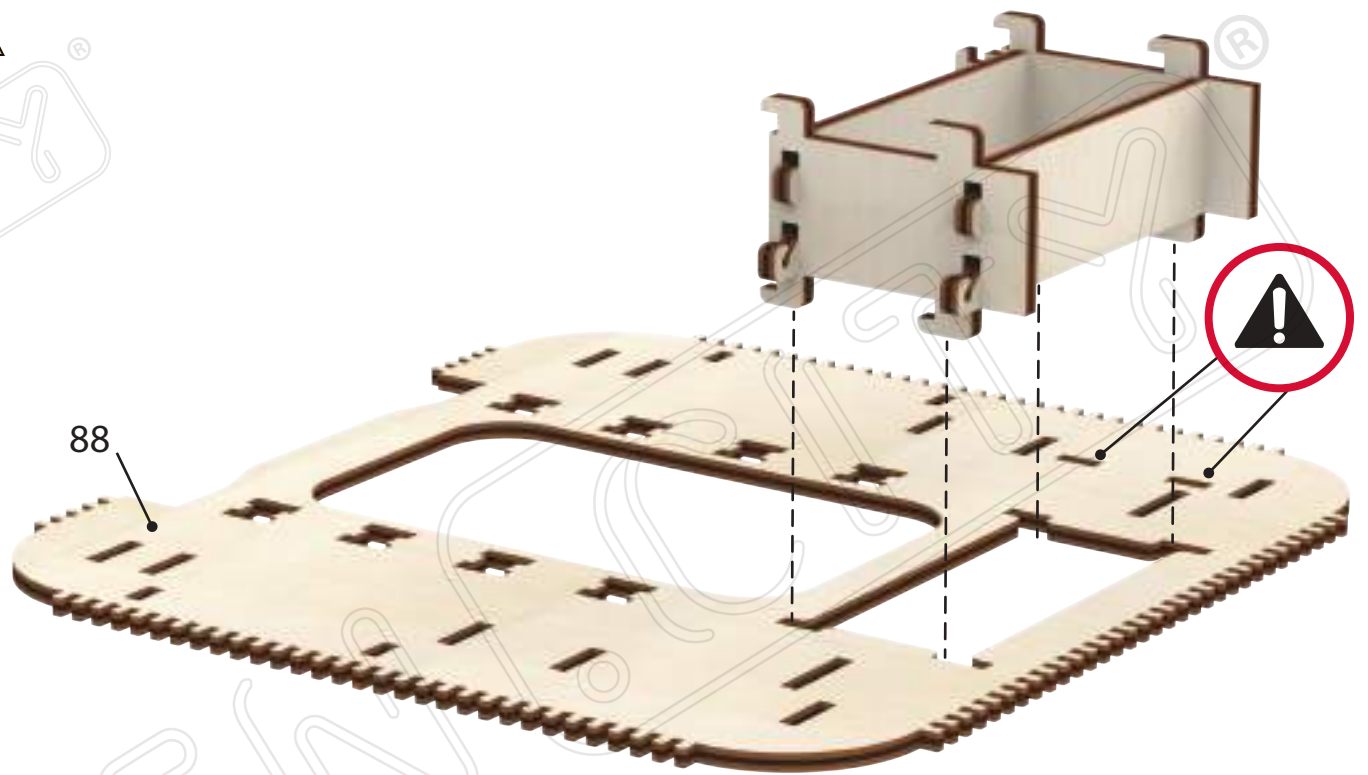
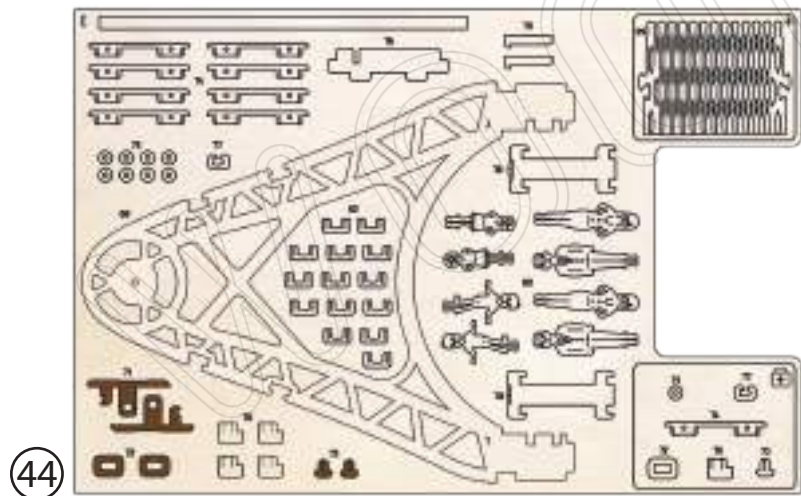
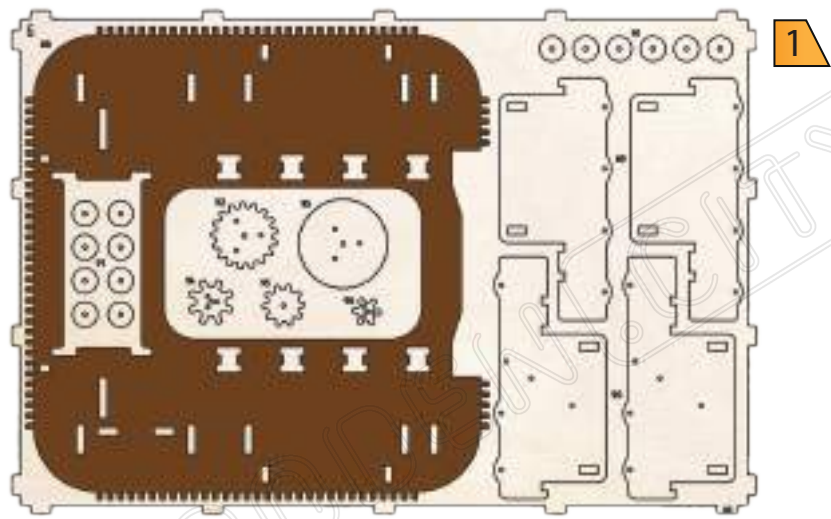

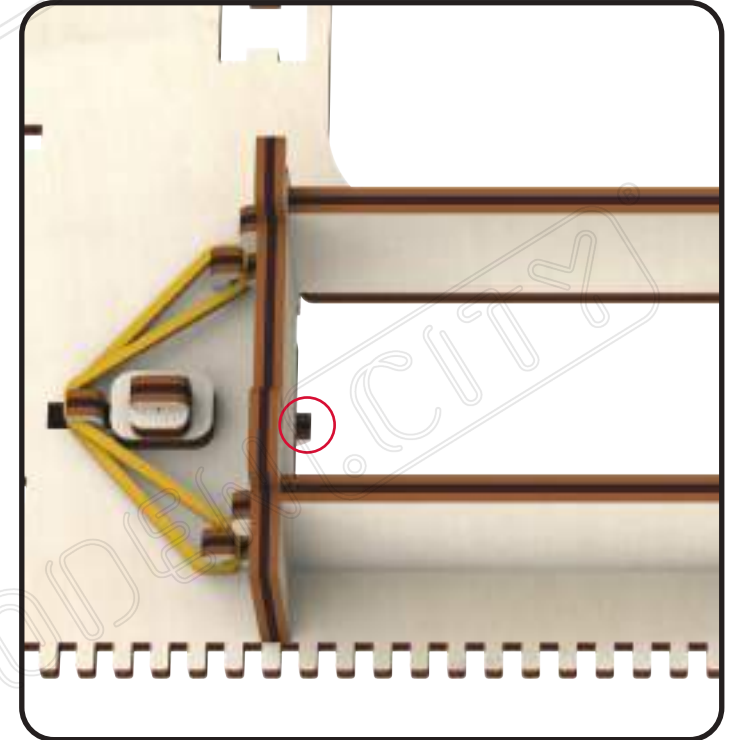
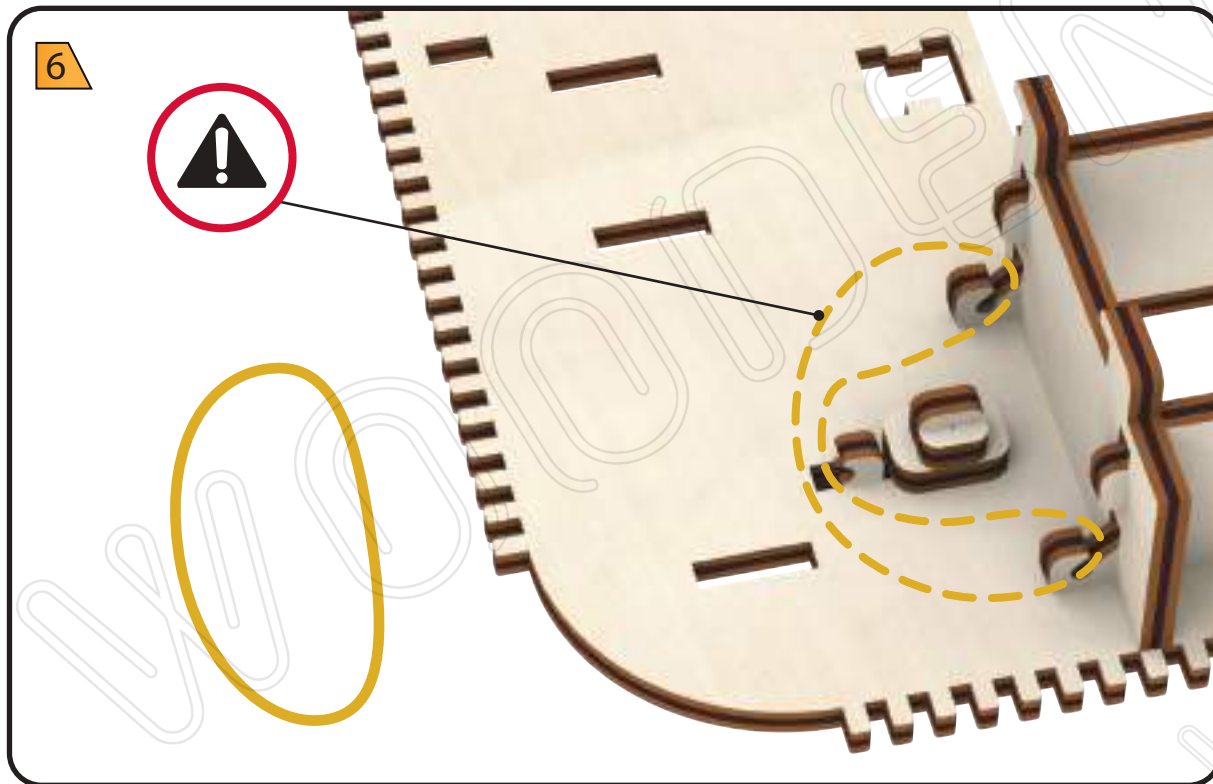
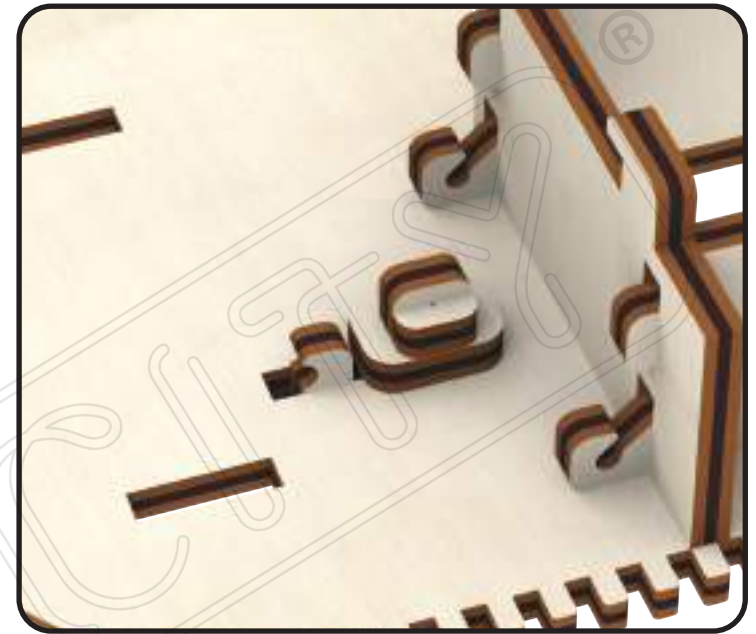
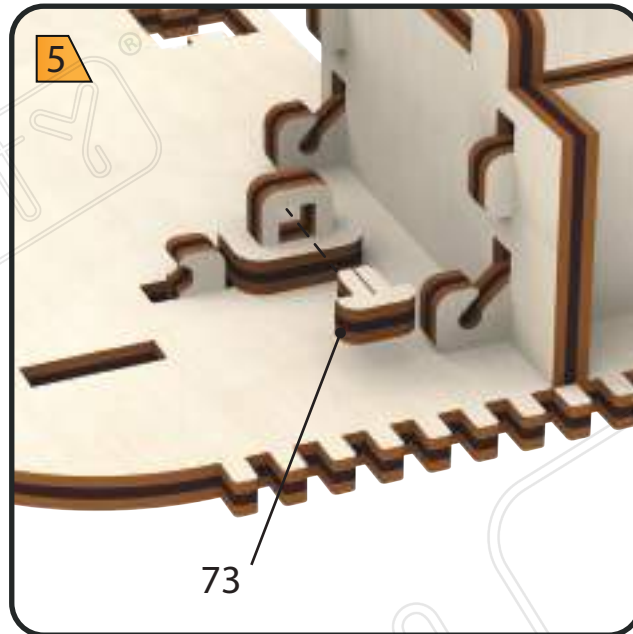
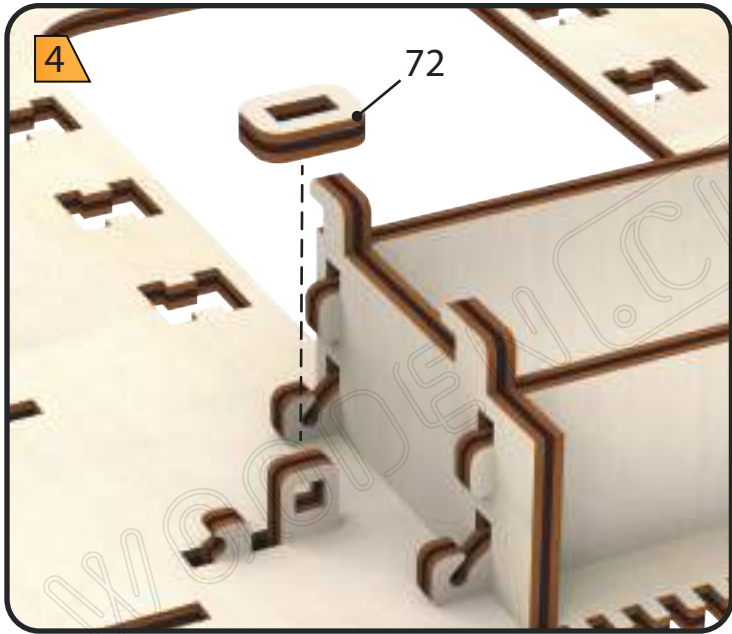

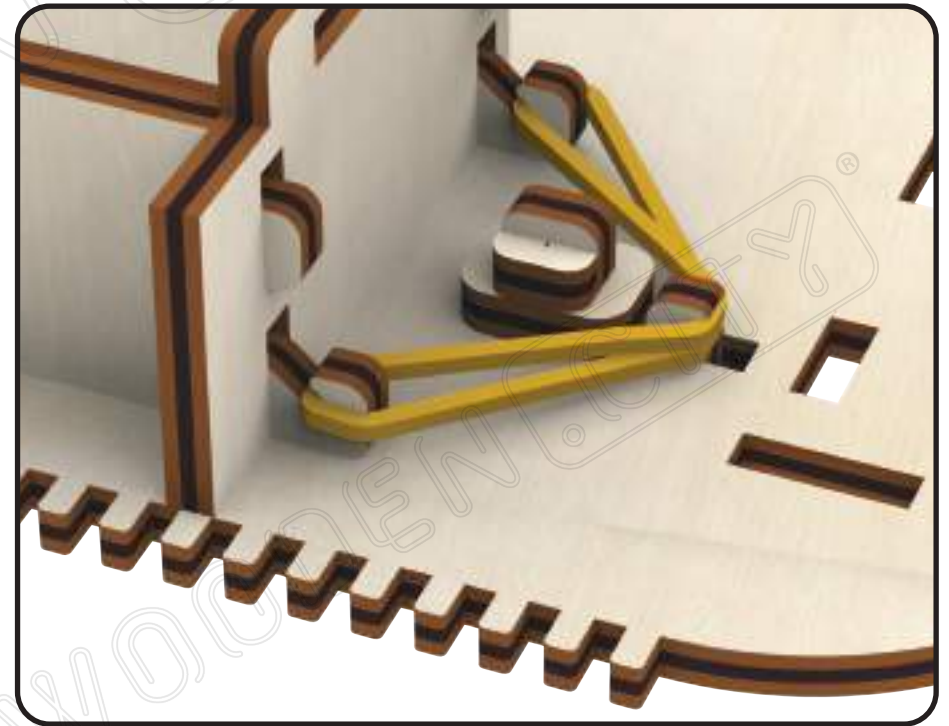
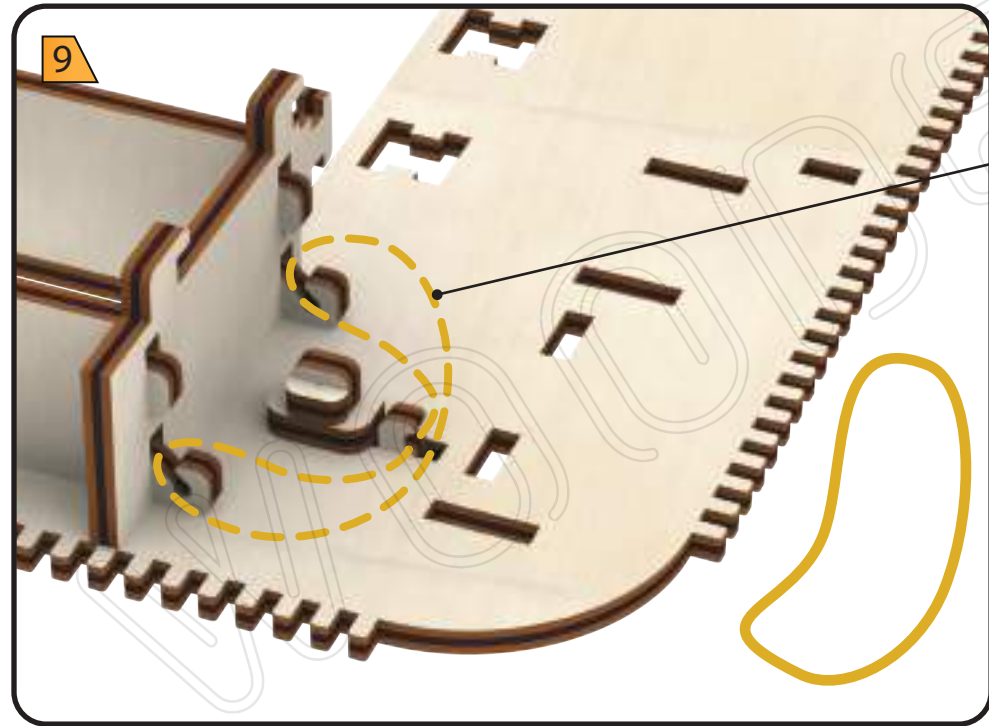
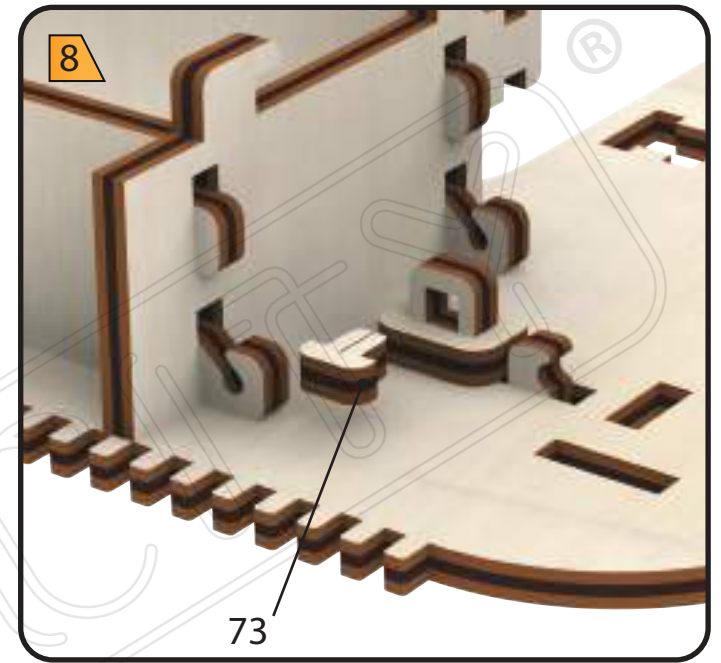
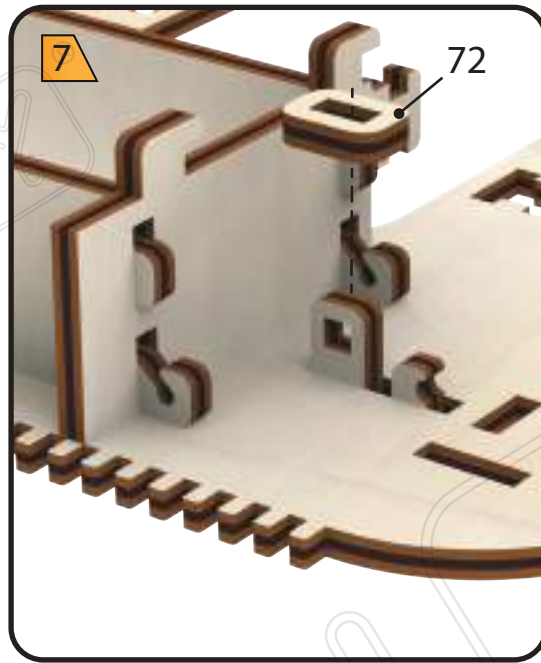
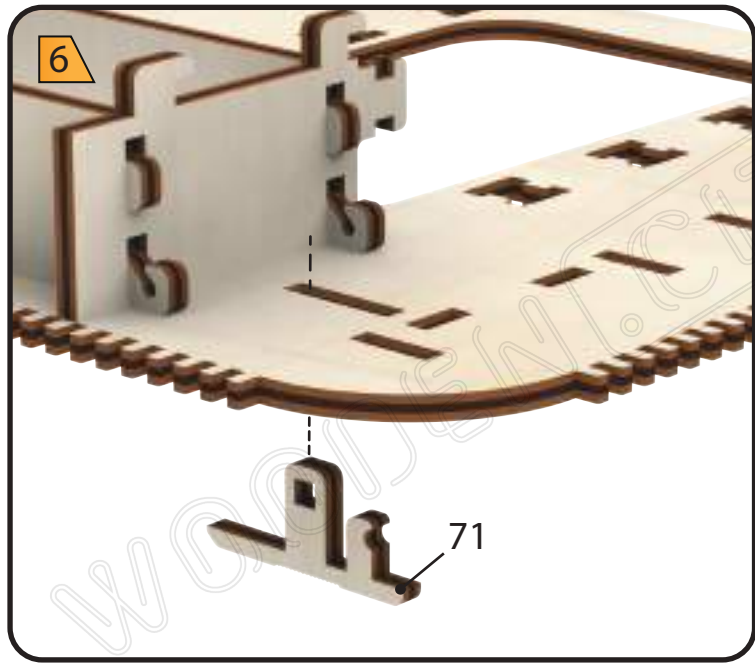

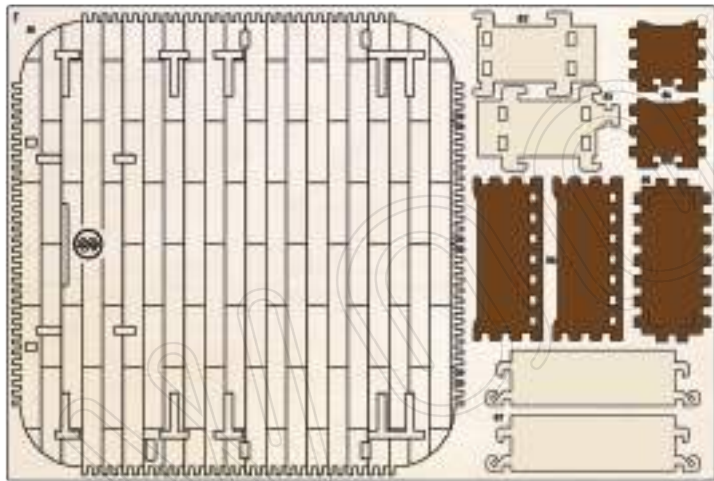
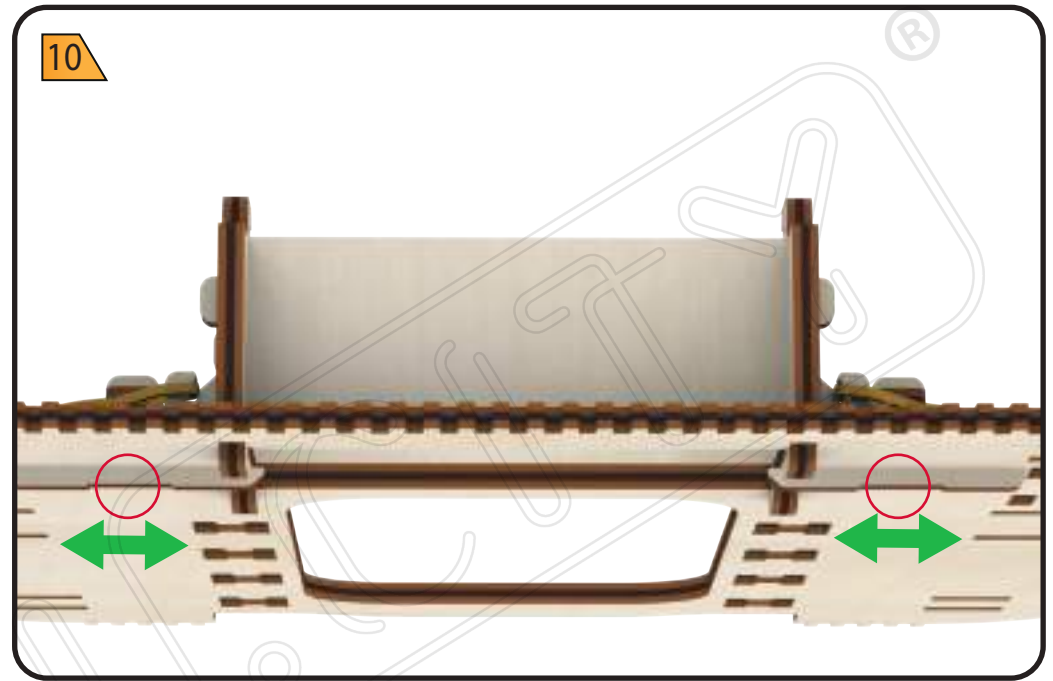

1

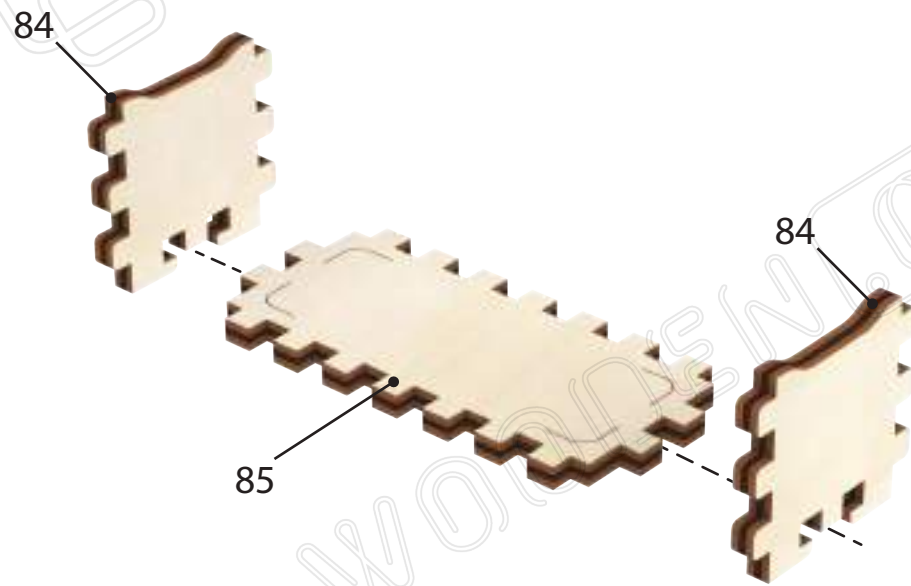

2

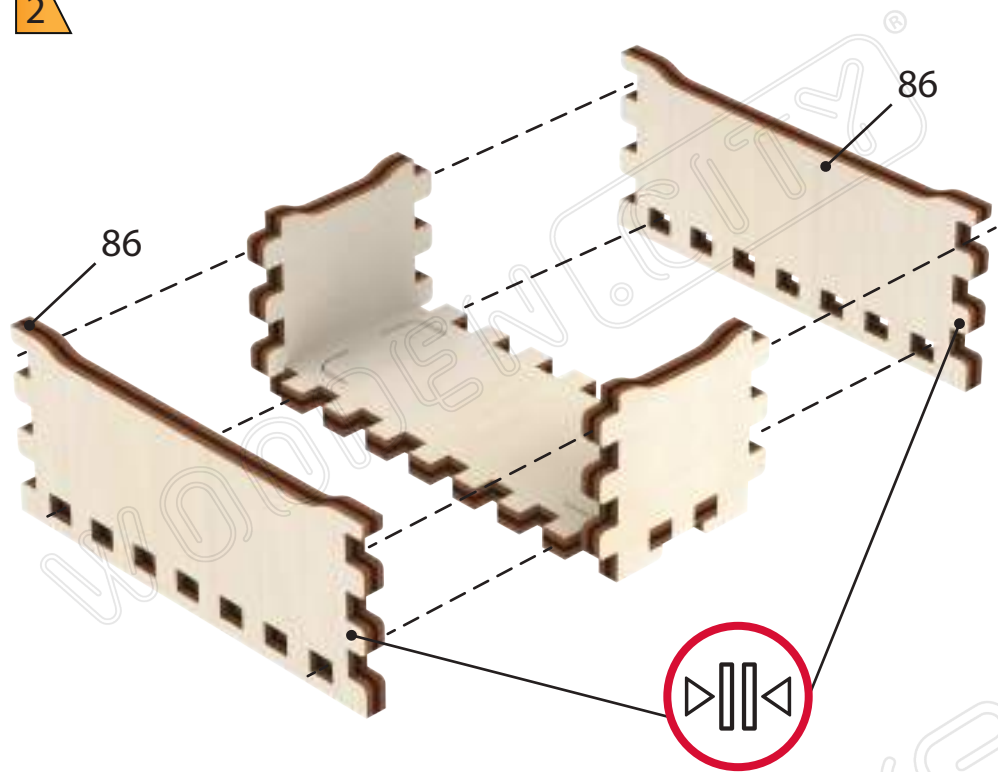

3

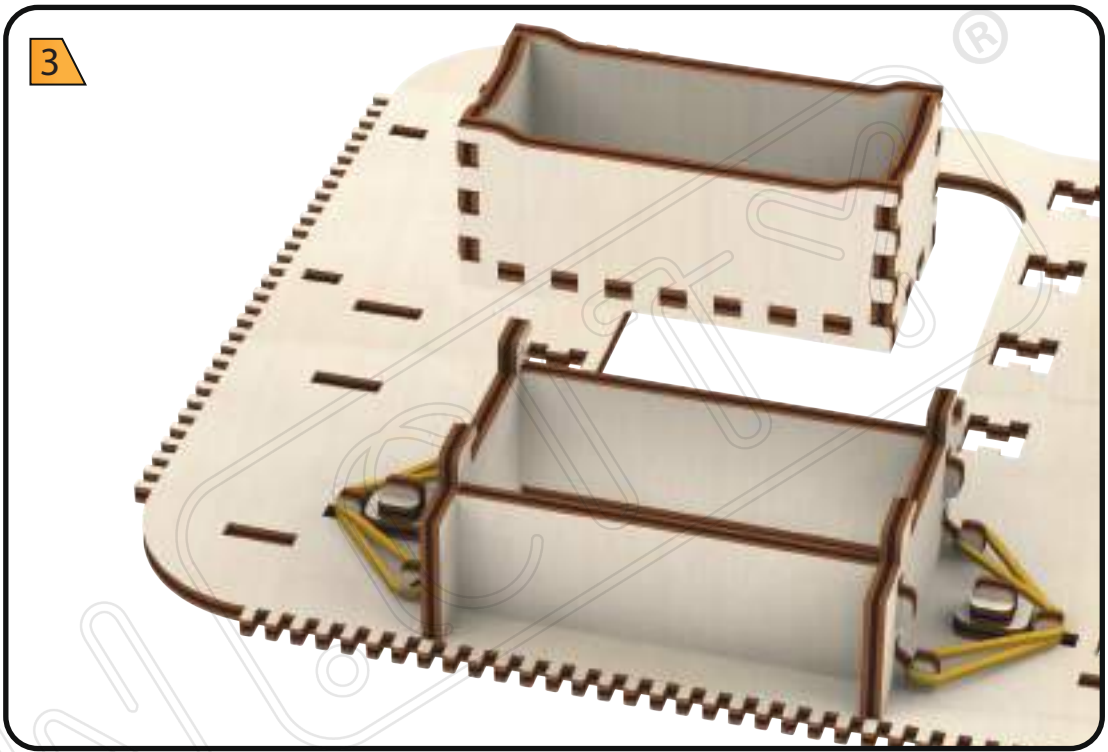

4

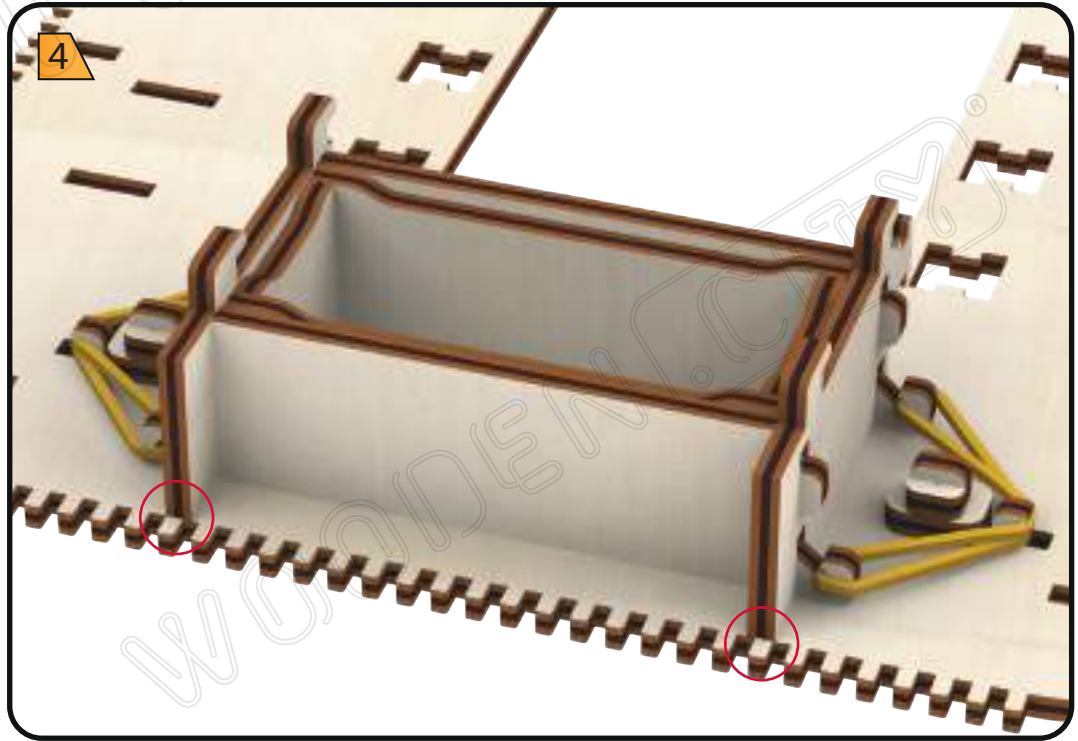

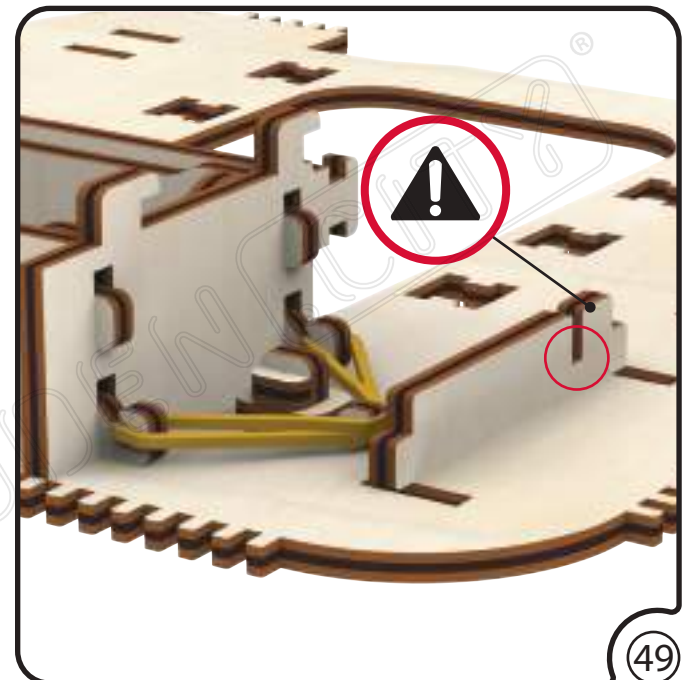
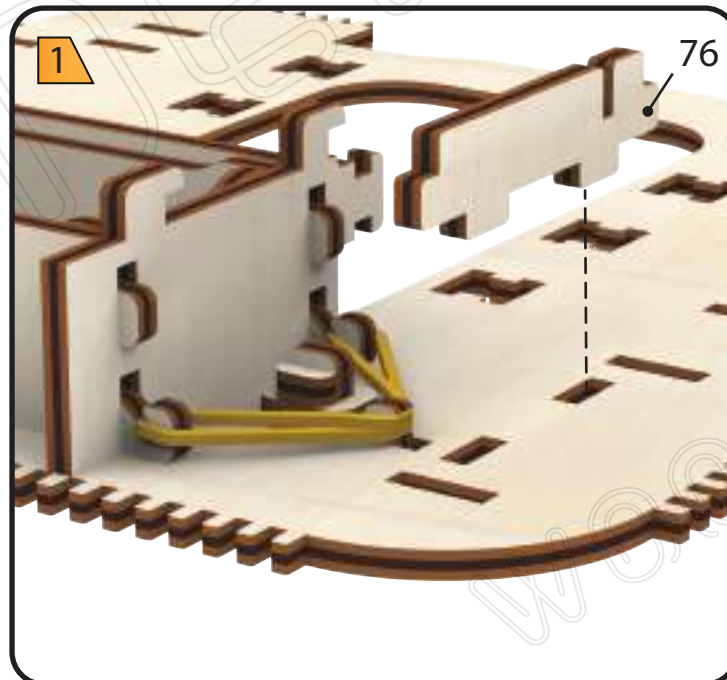
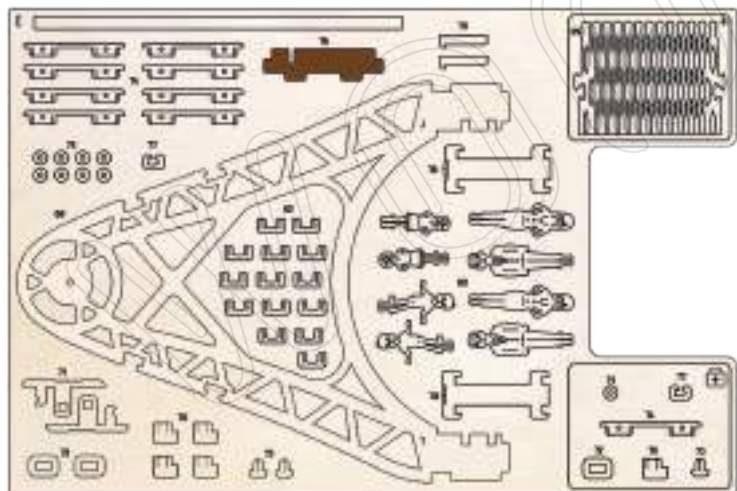
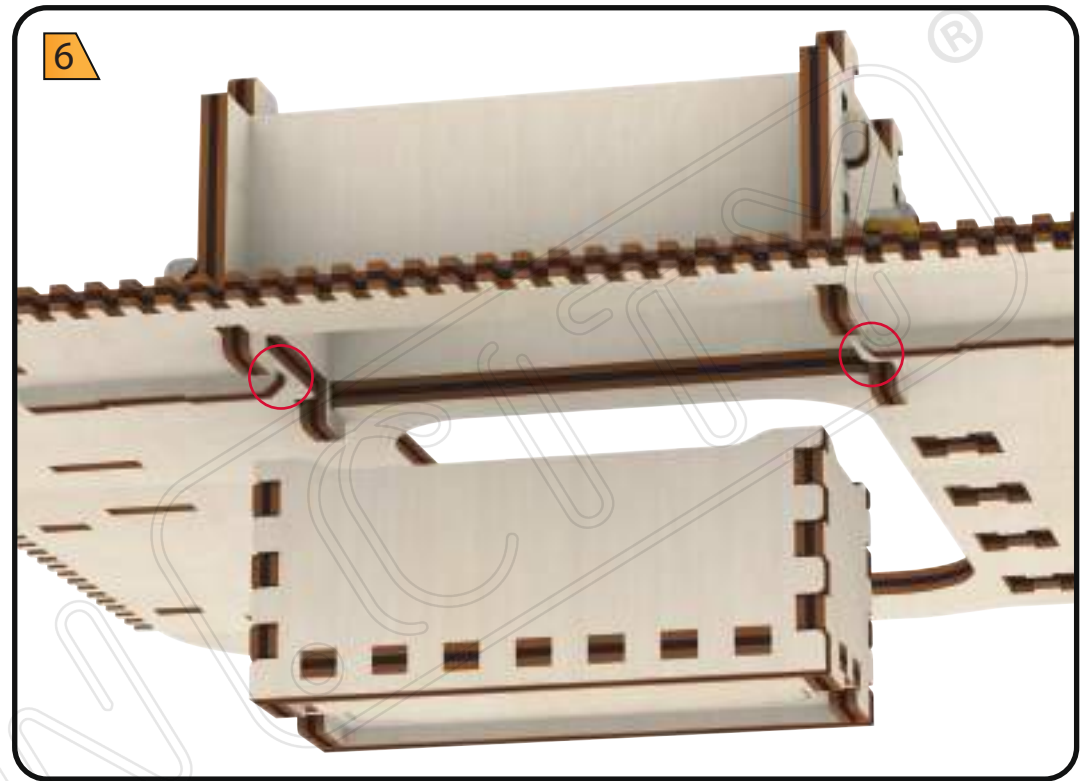
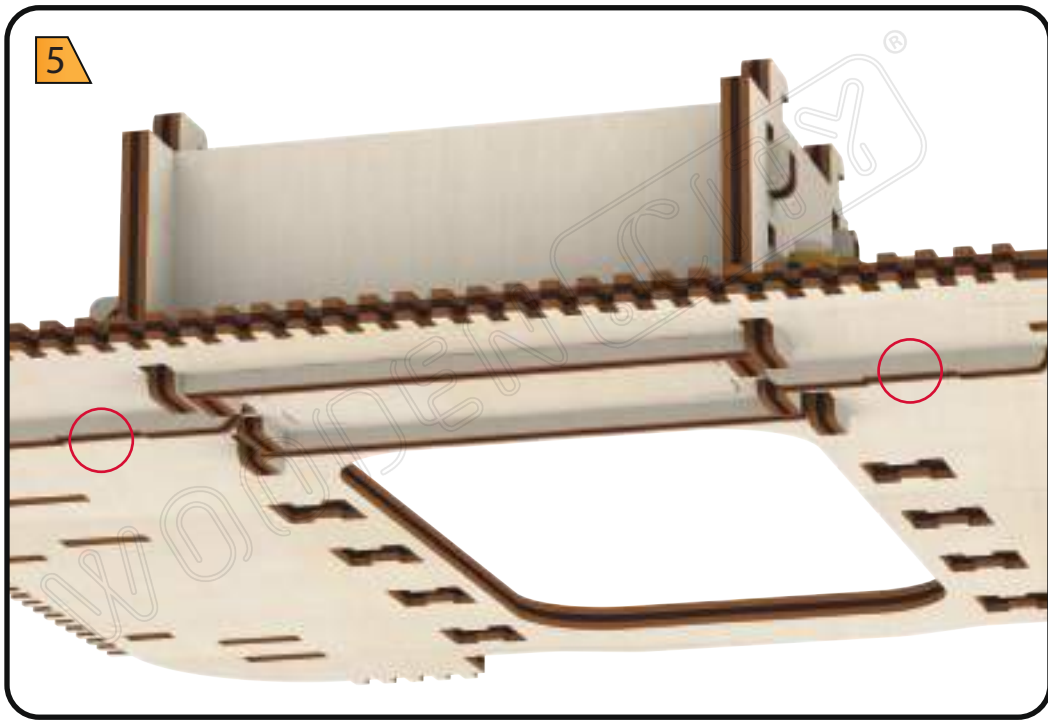

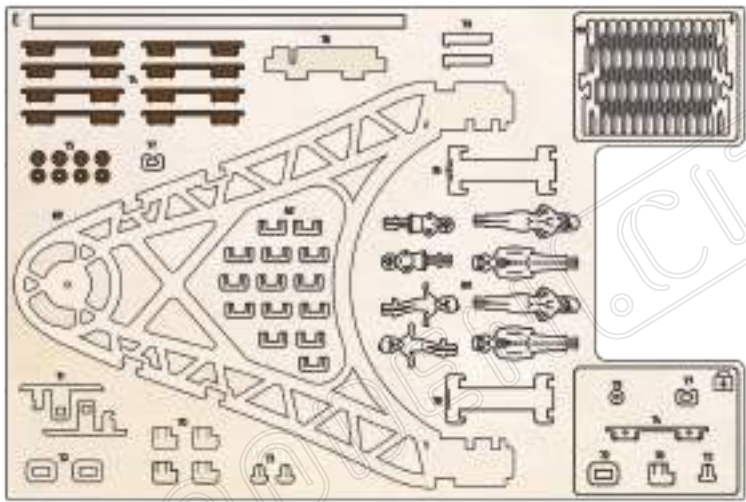

1



2

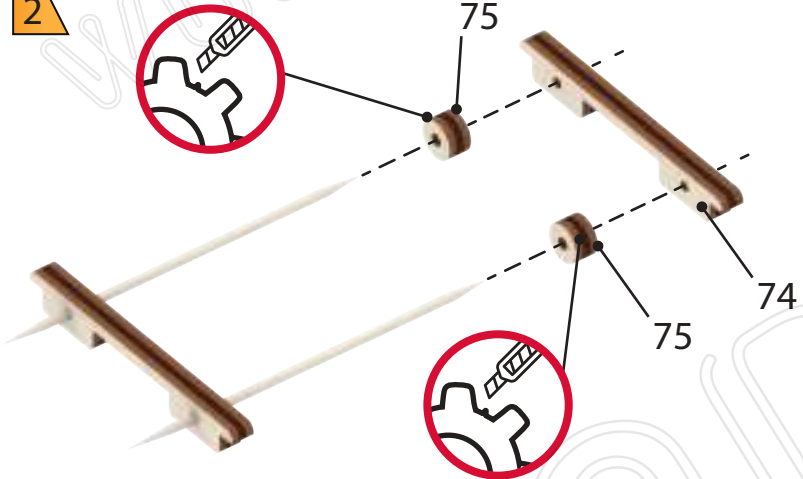

3



4

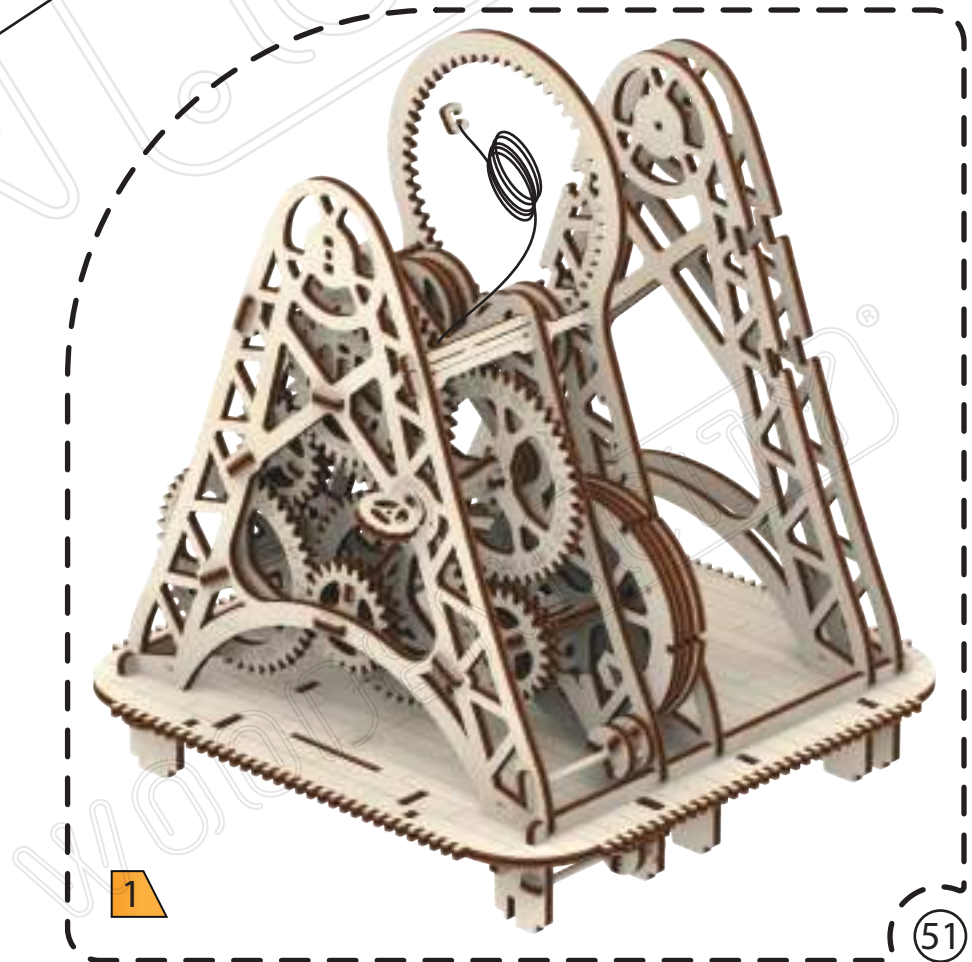
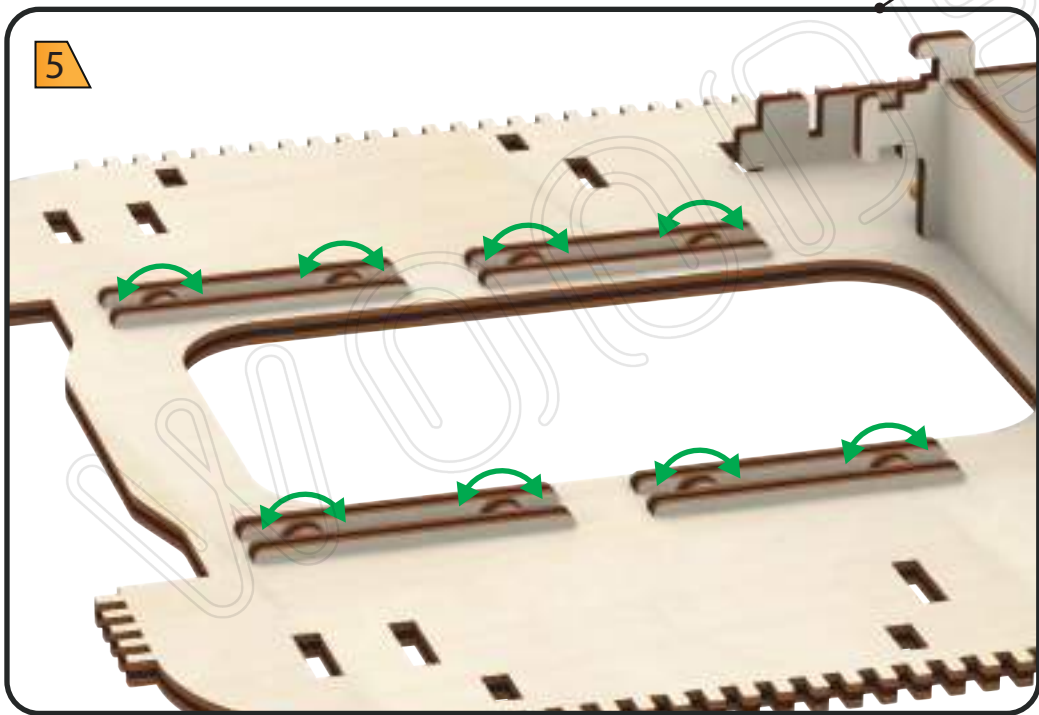
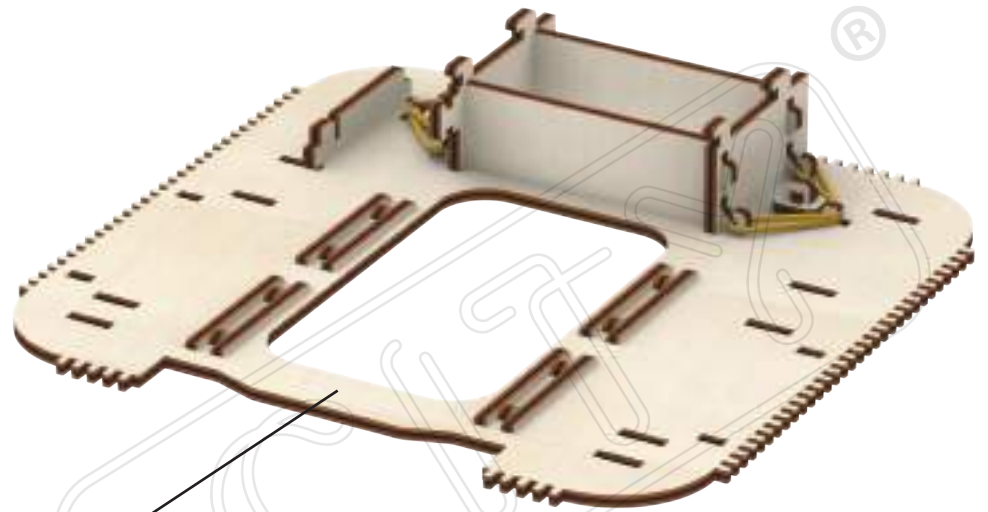
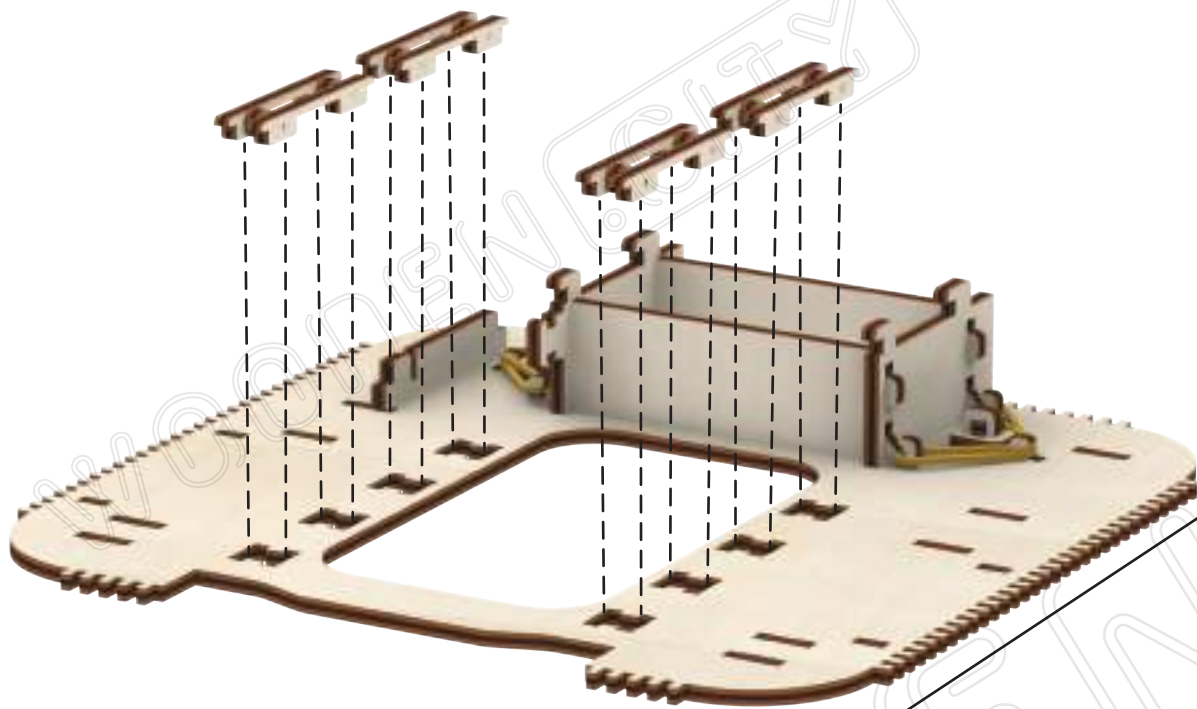

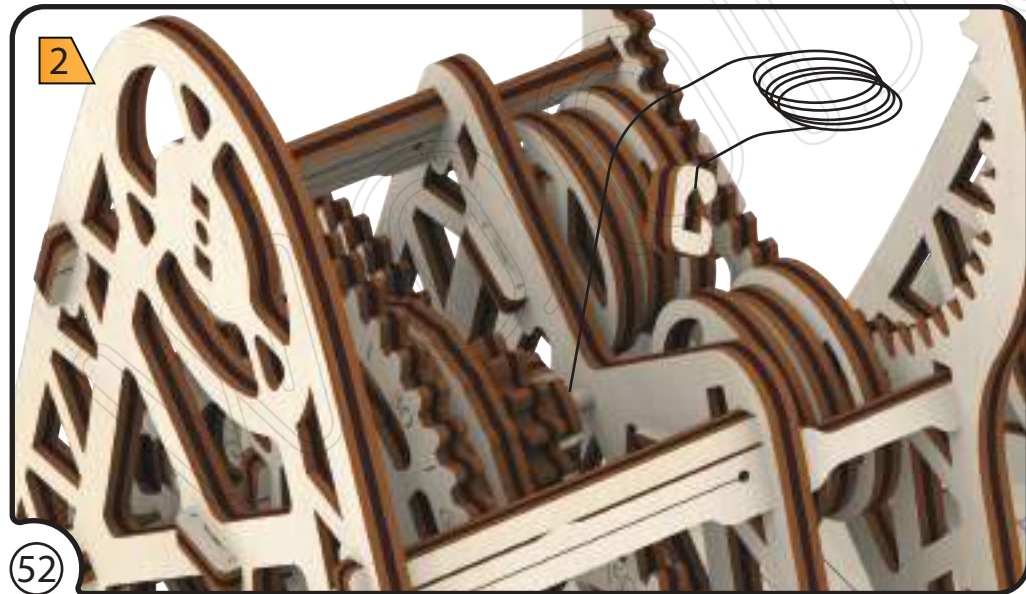
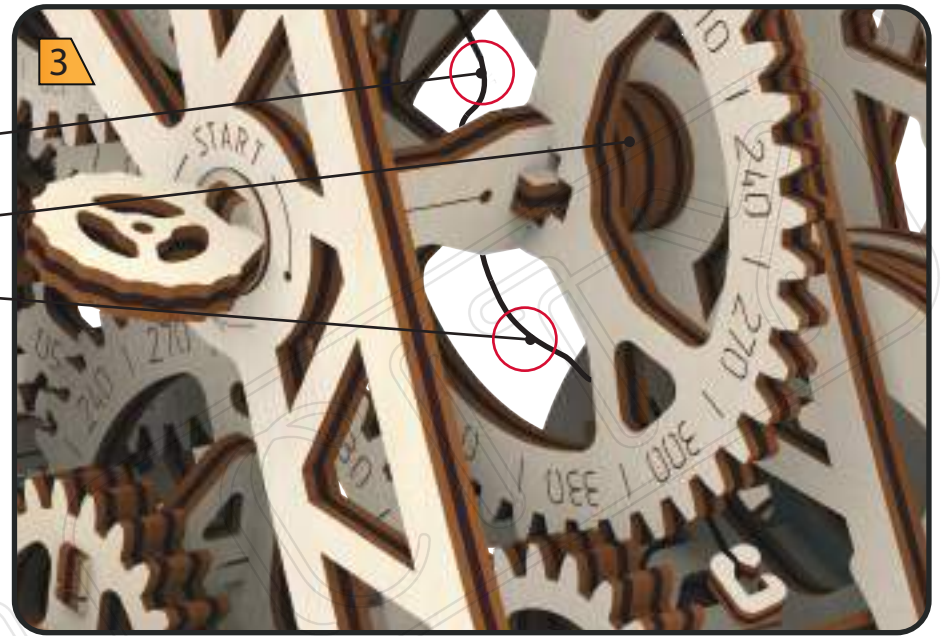
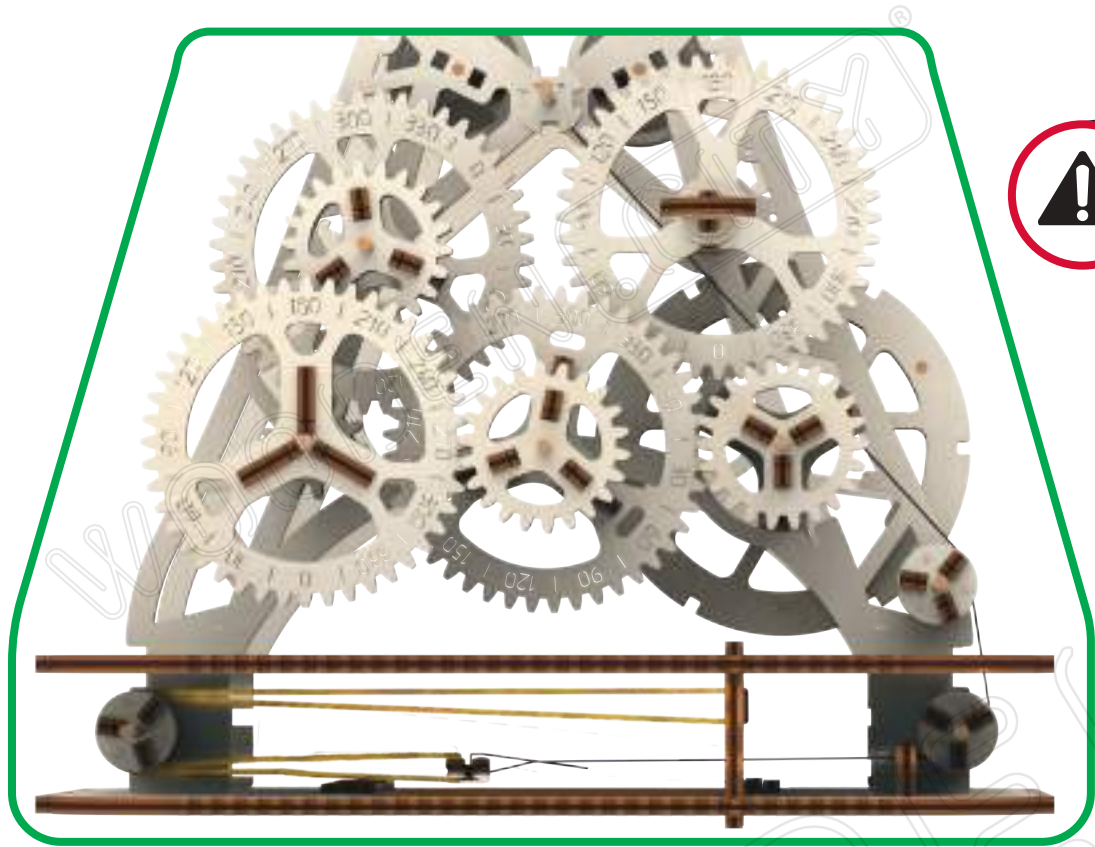

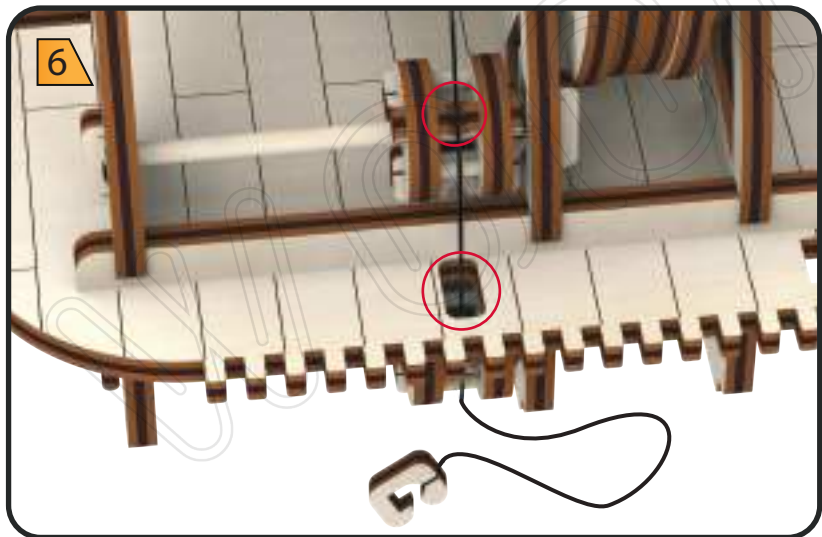
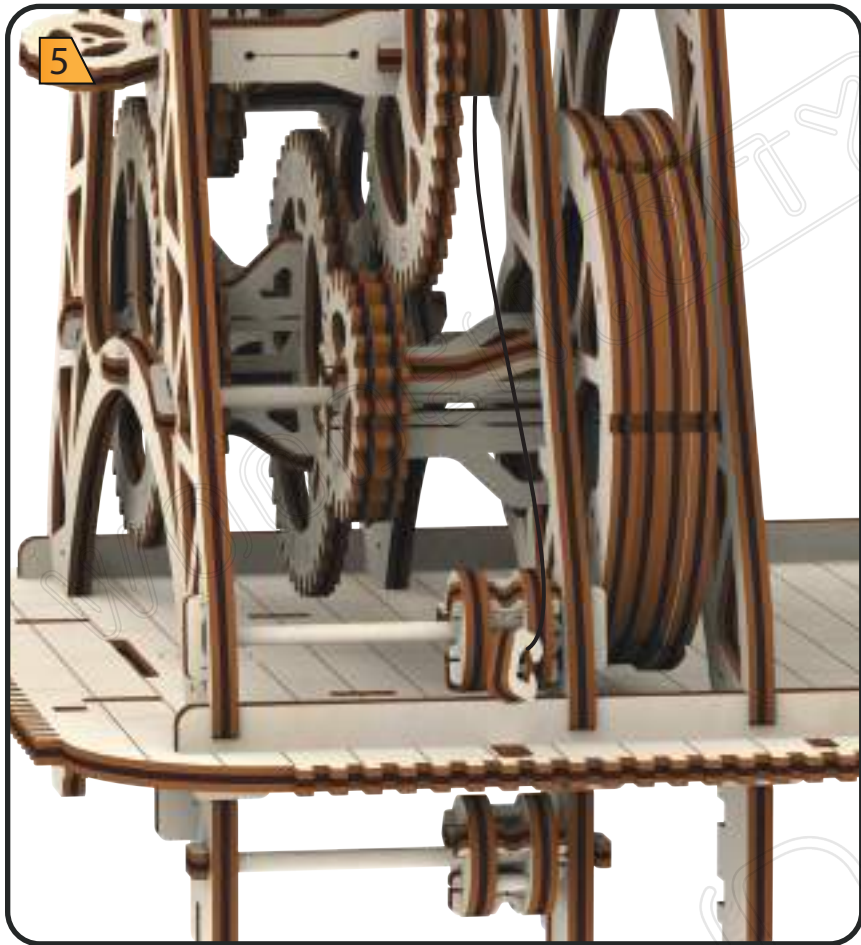

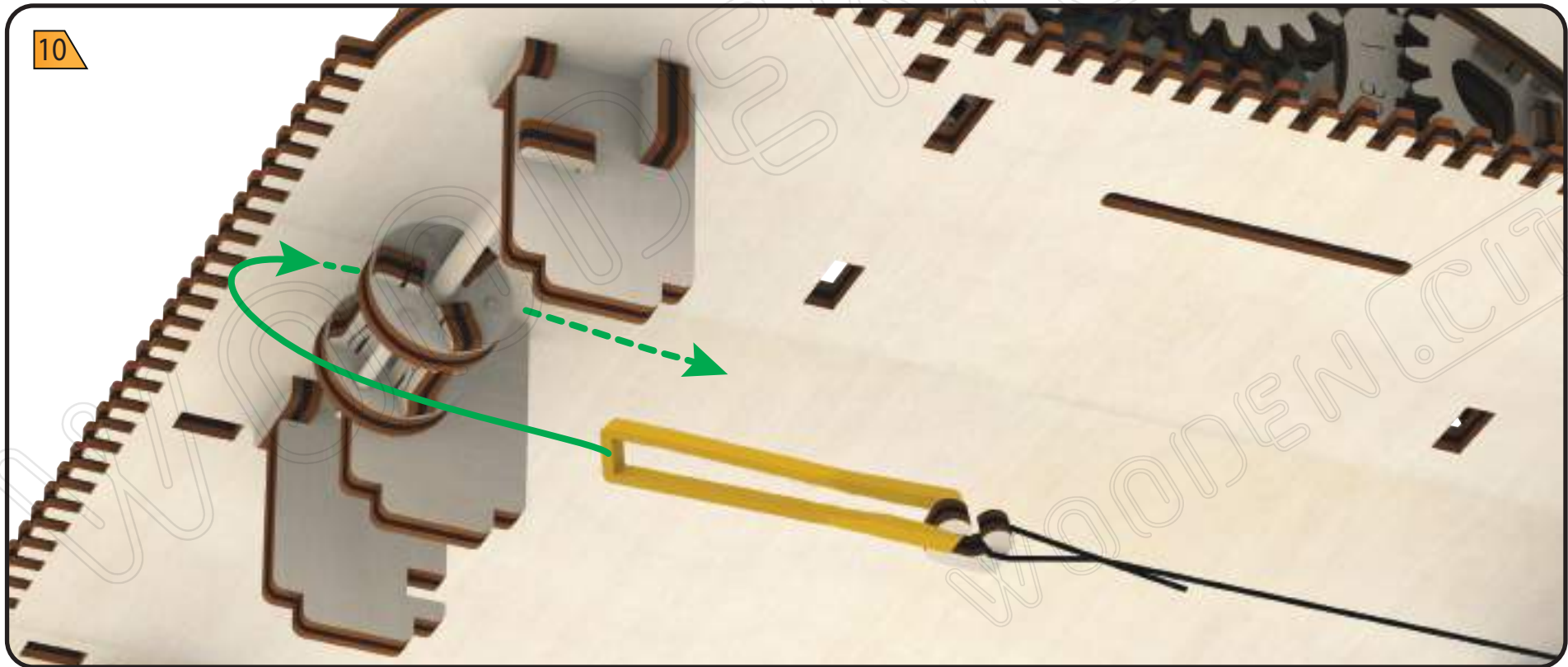
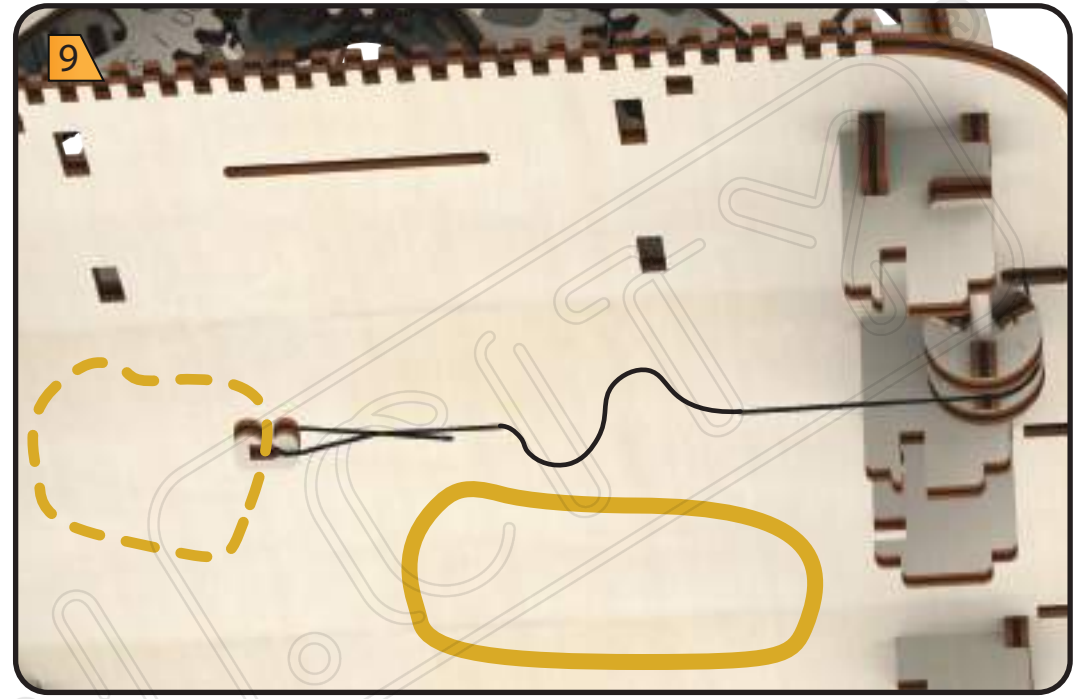
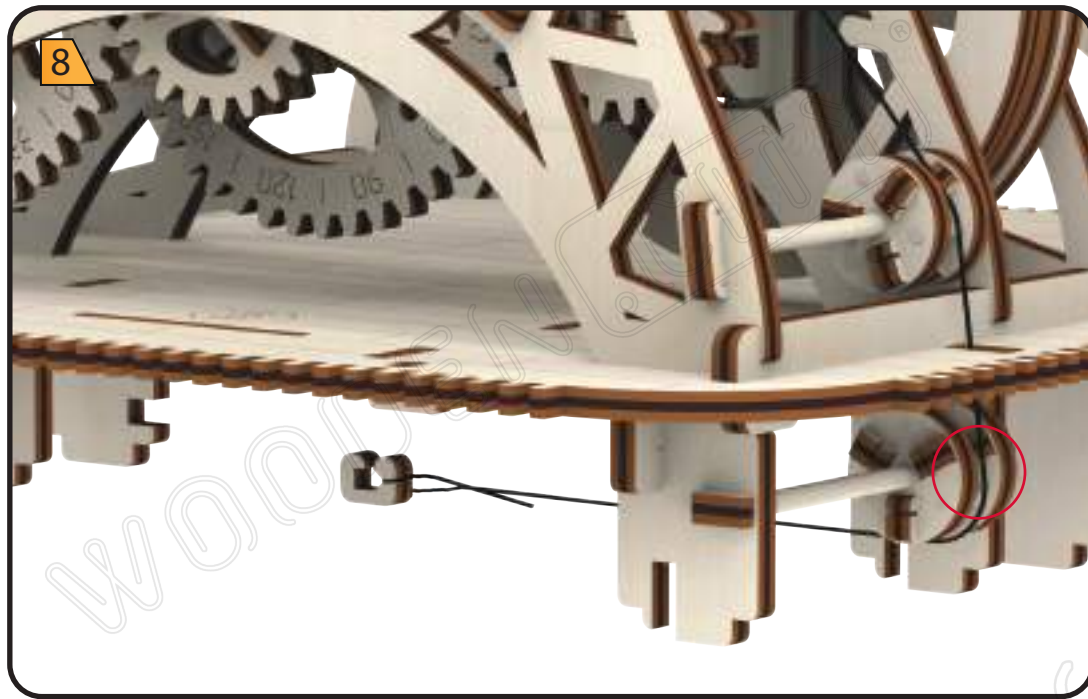

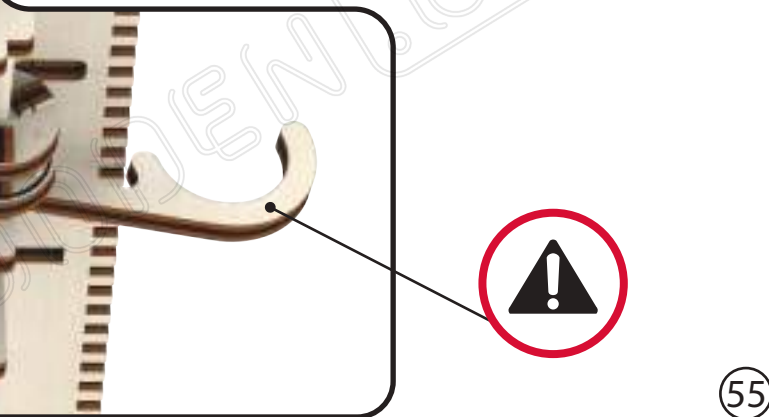
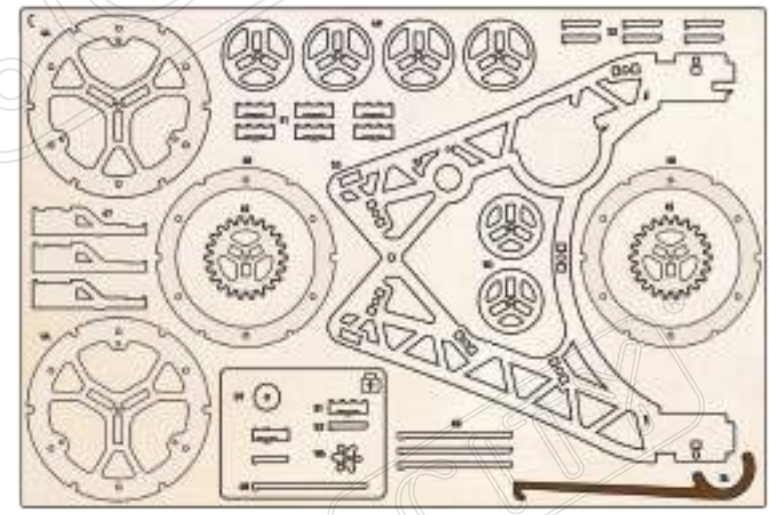
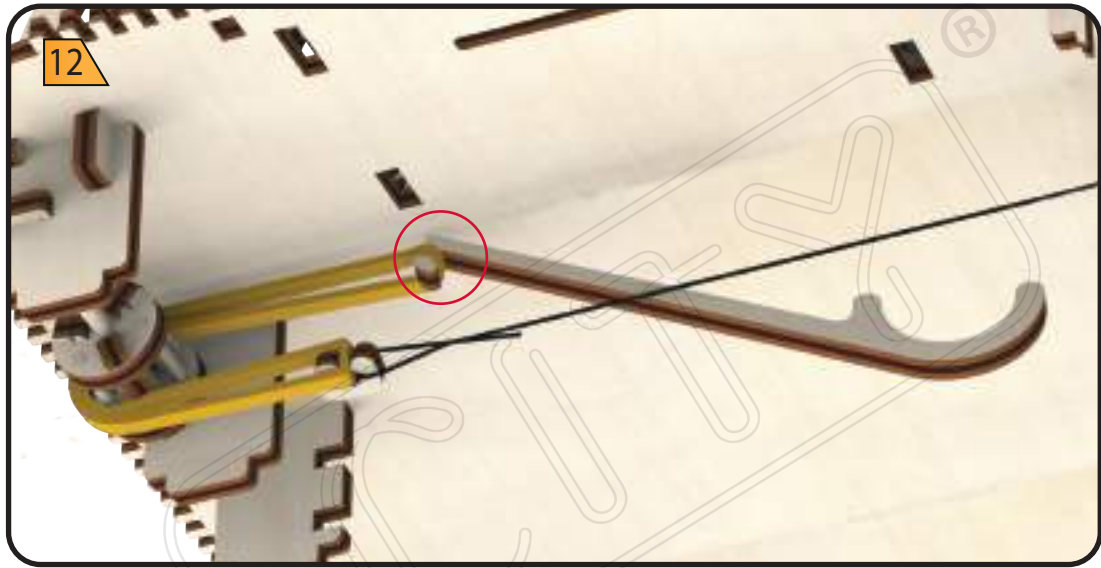
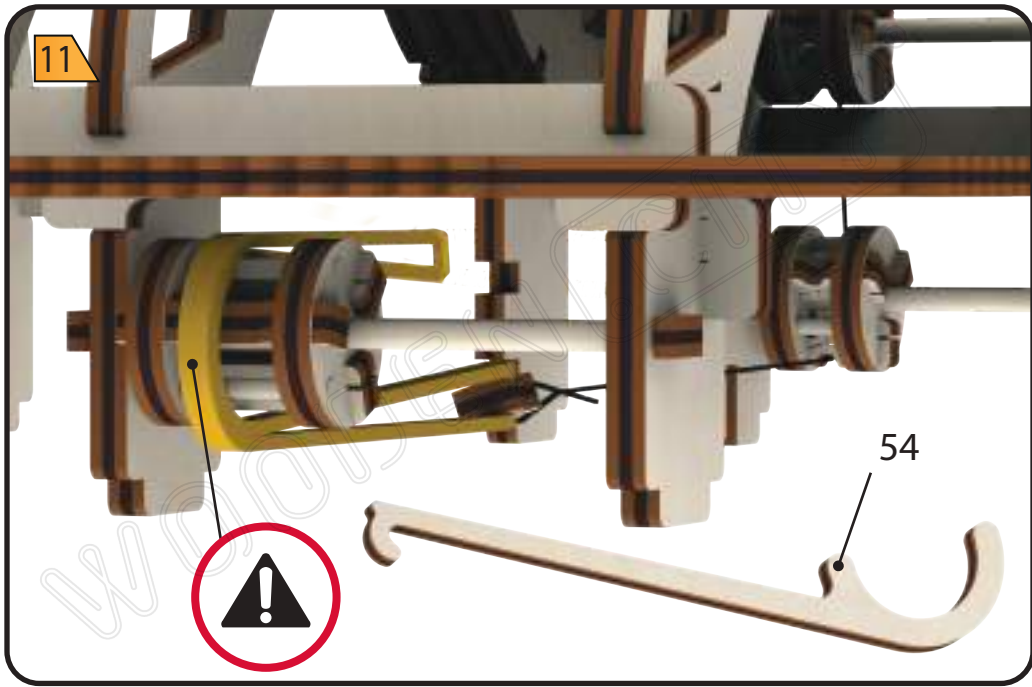

14

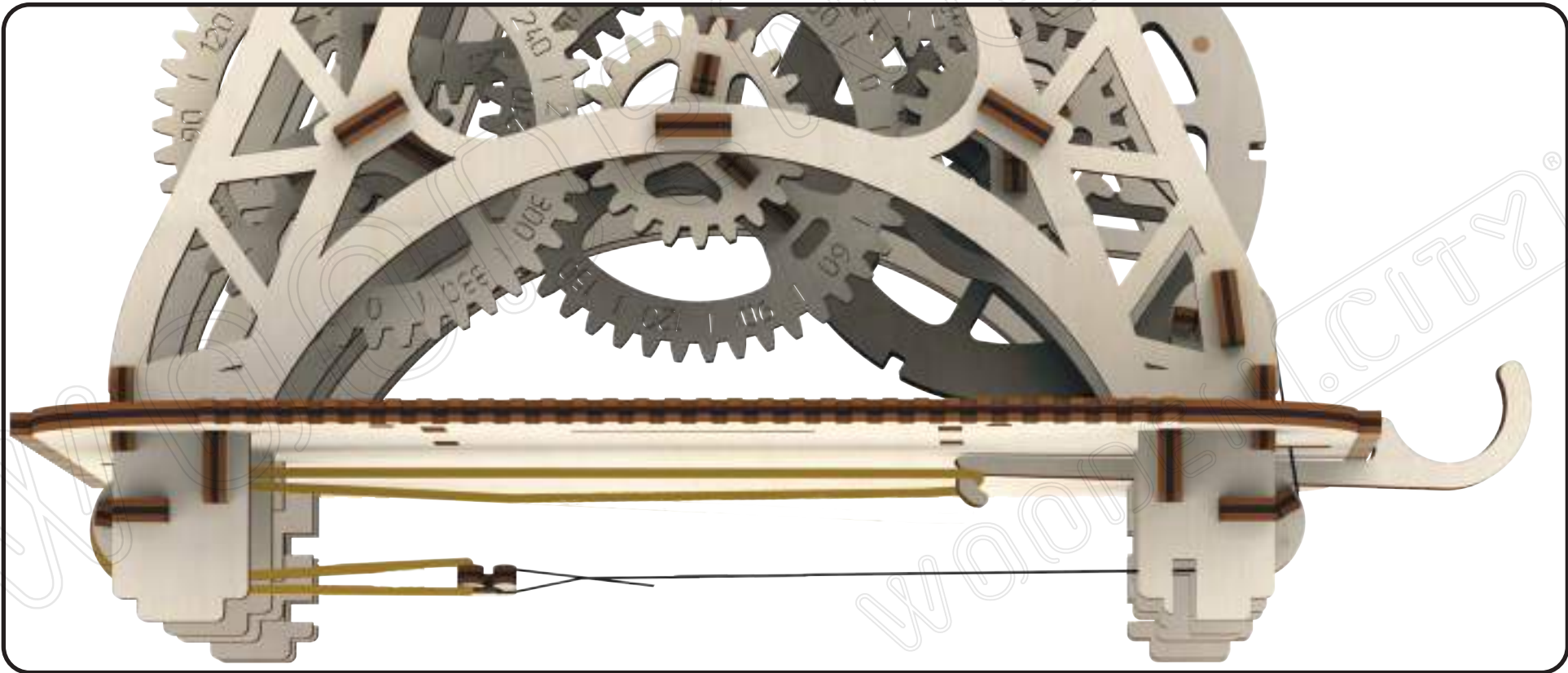
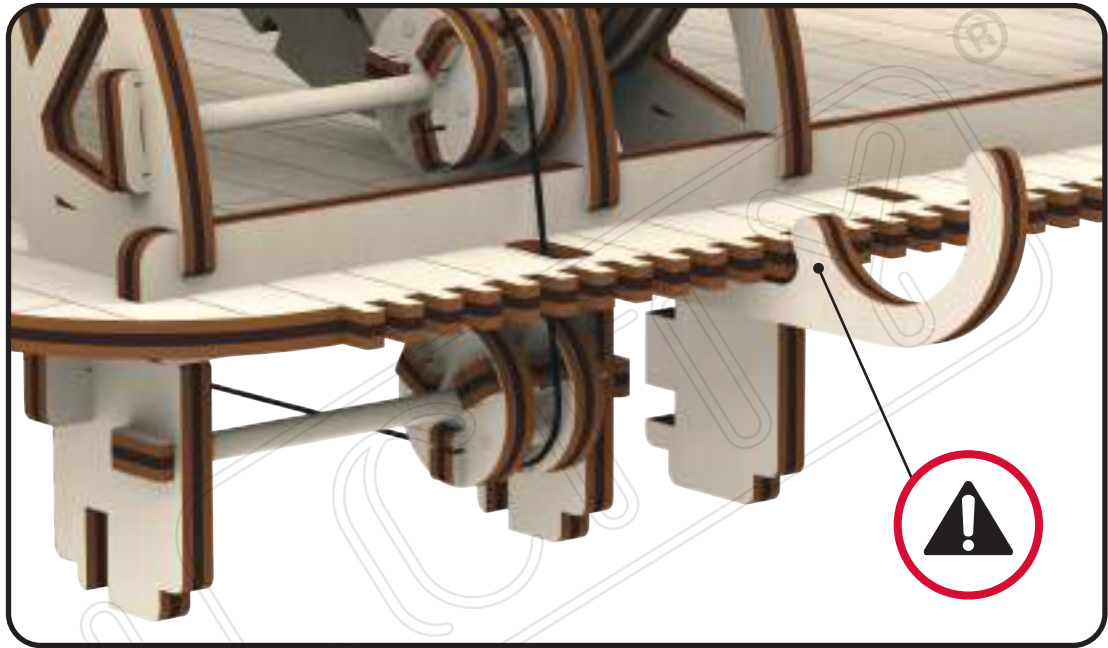
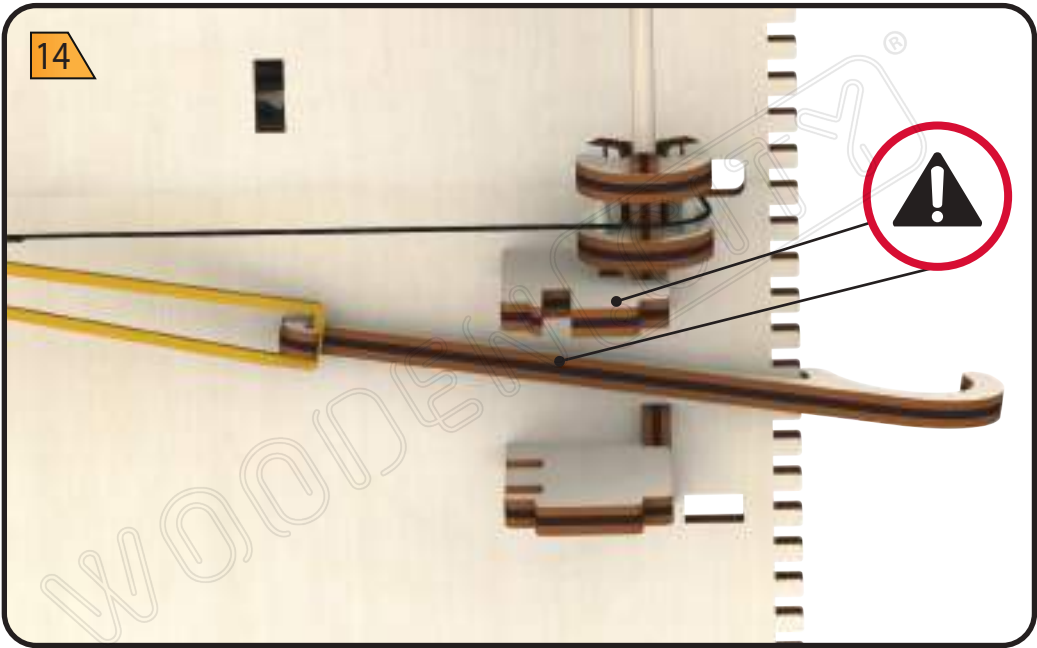

56

1

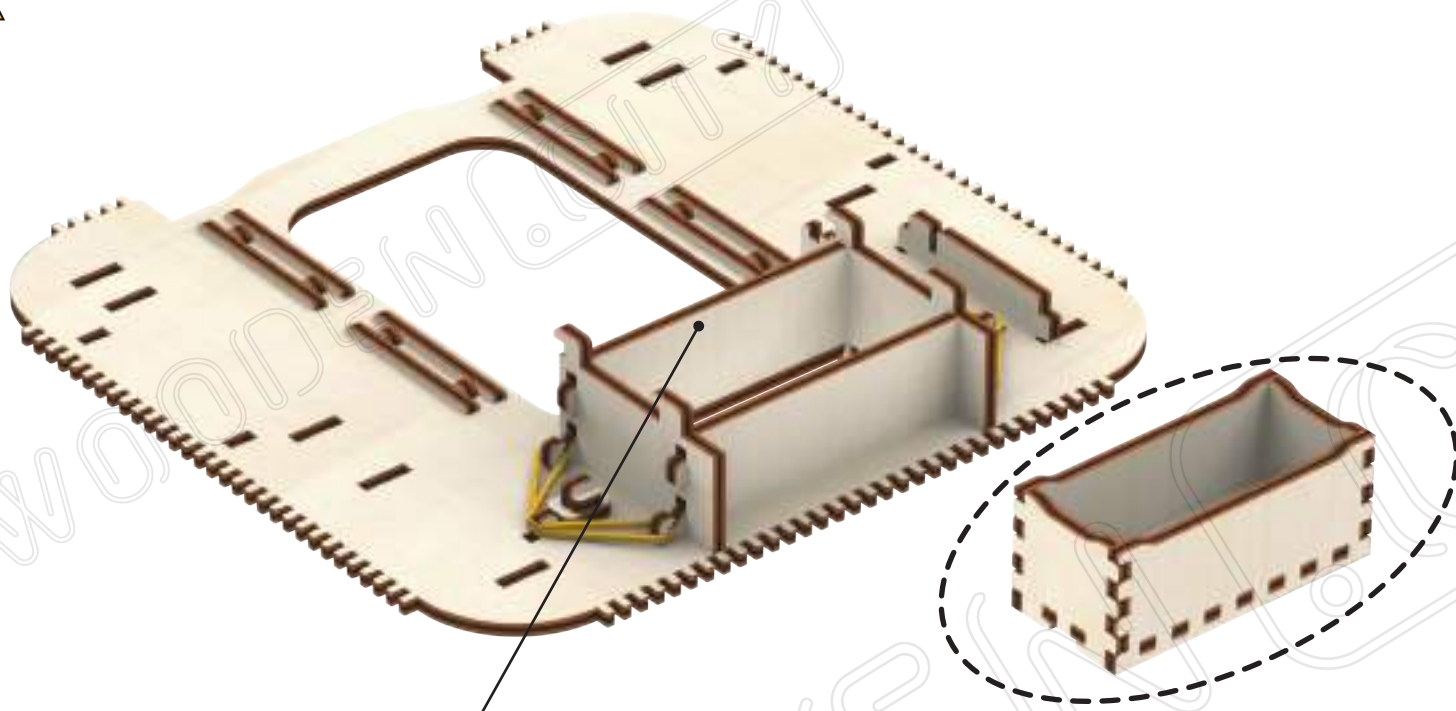

2

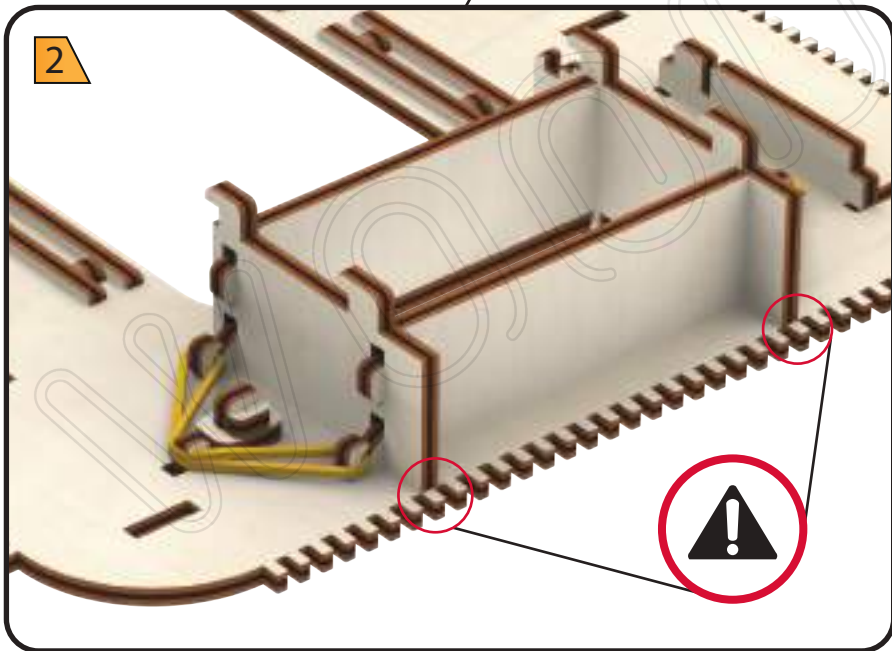

3

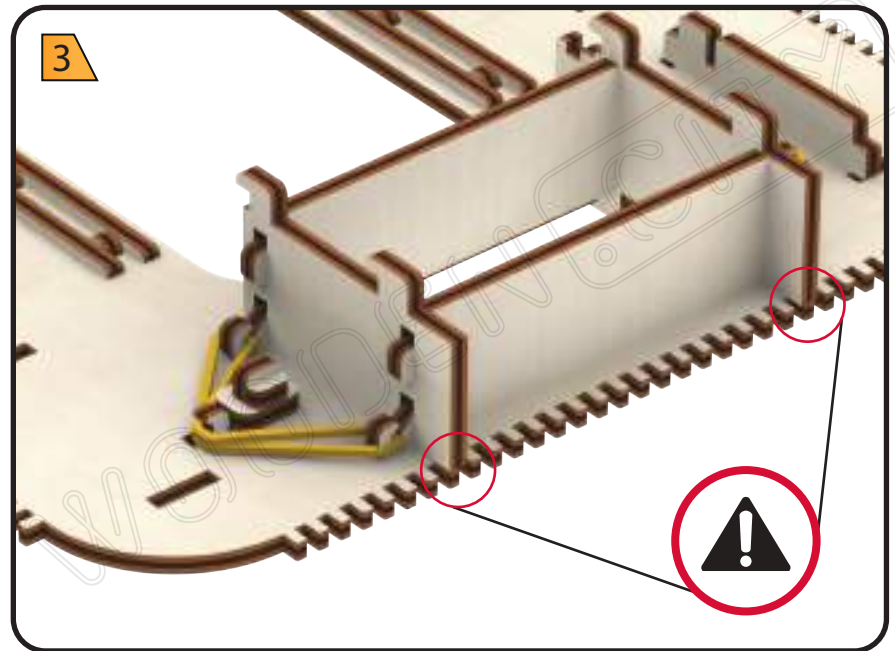

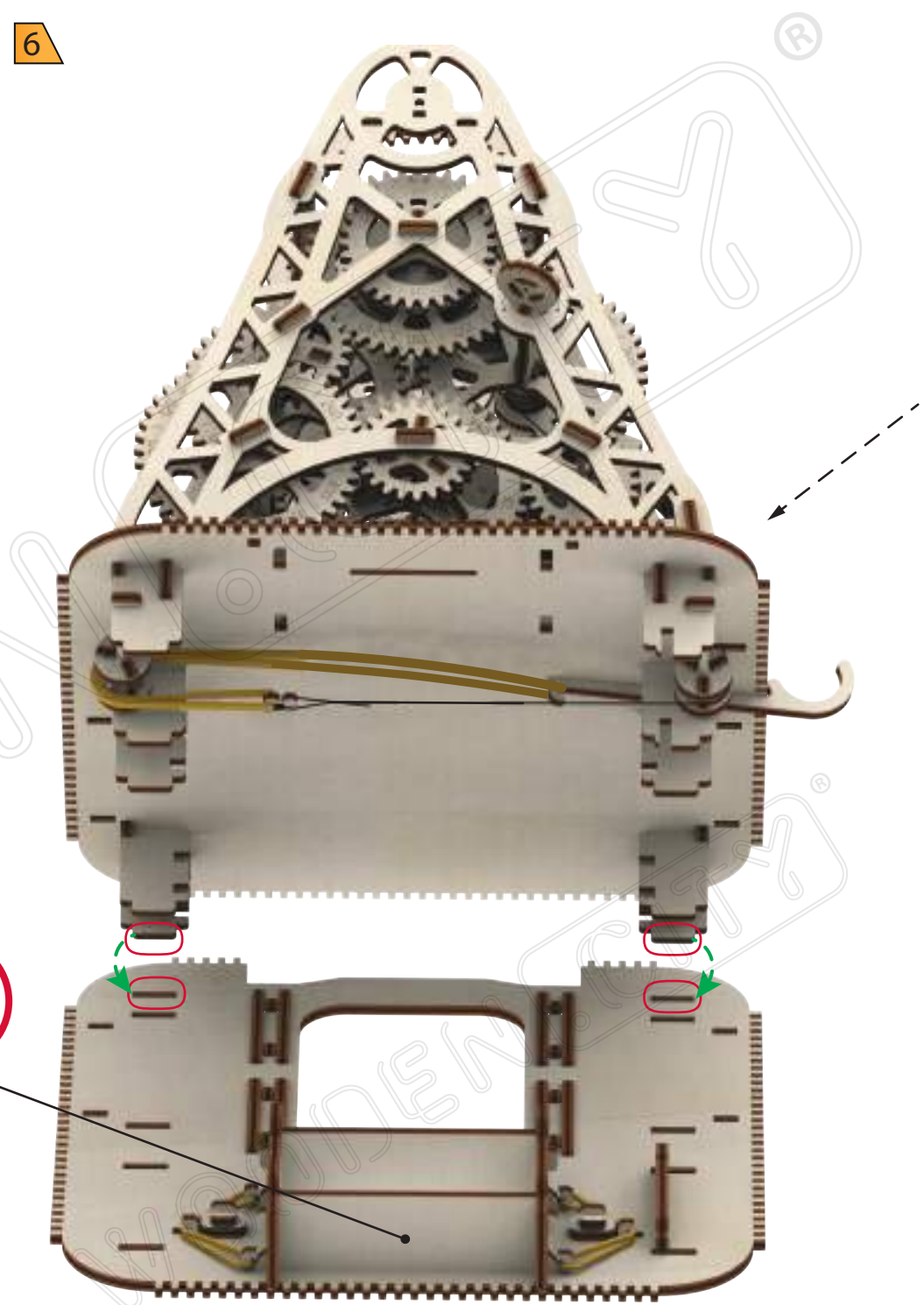
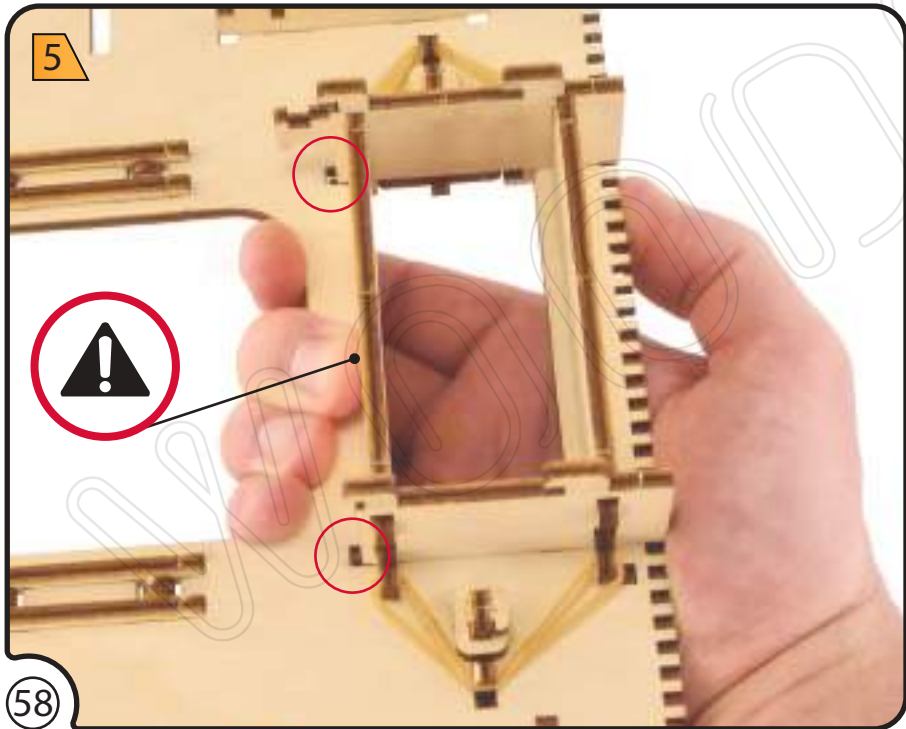
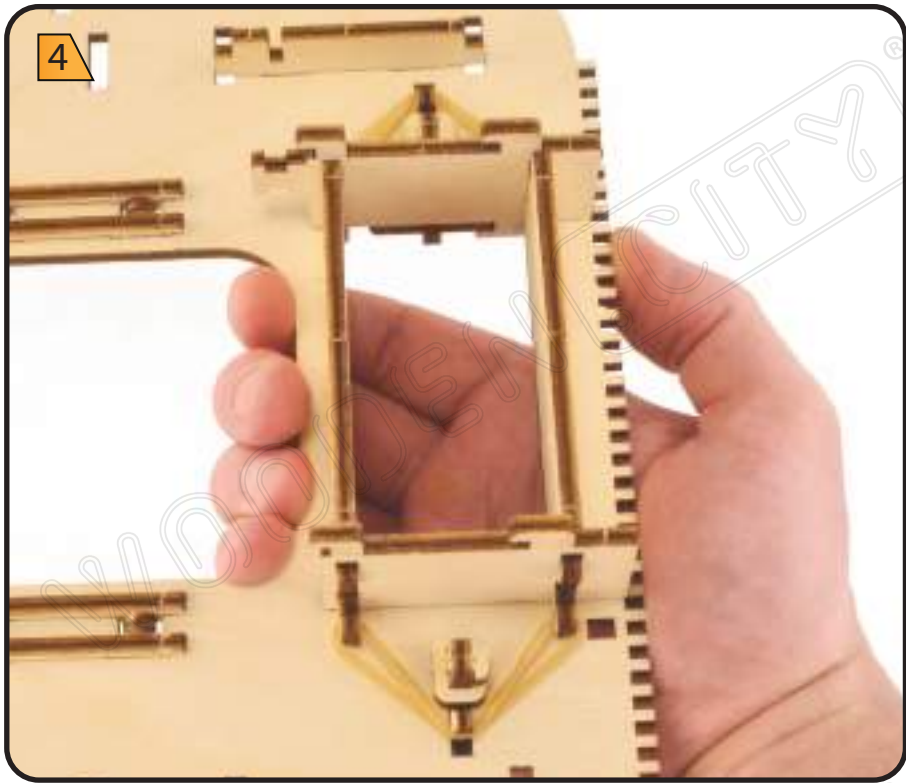

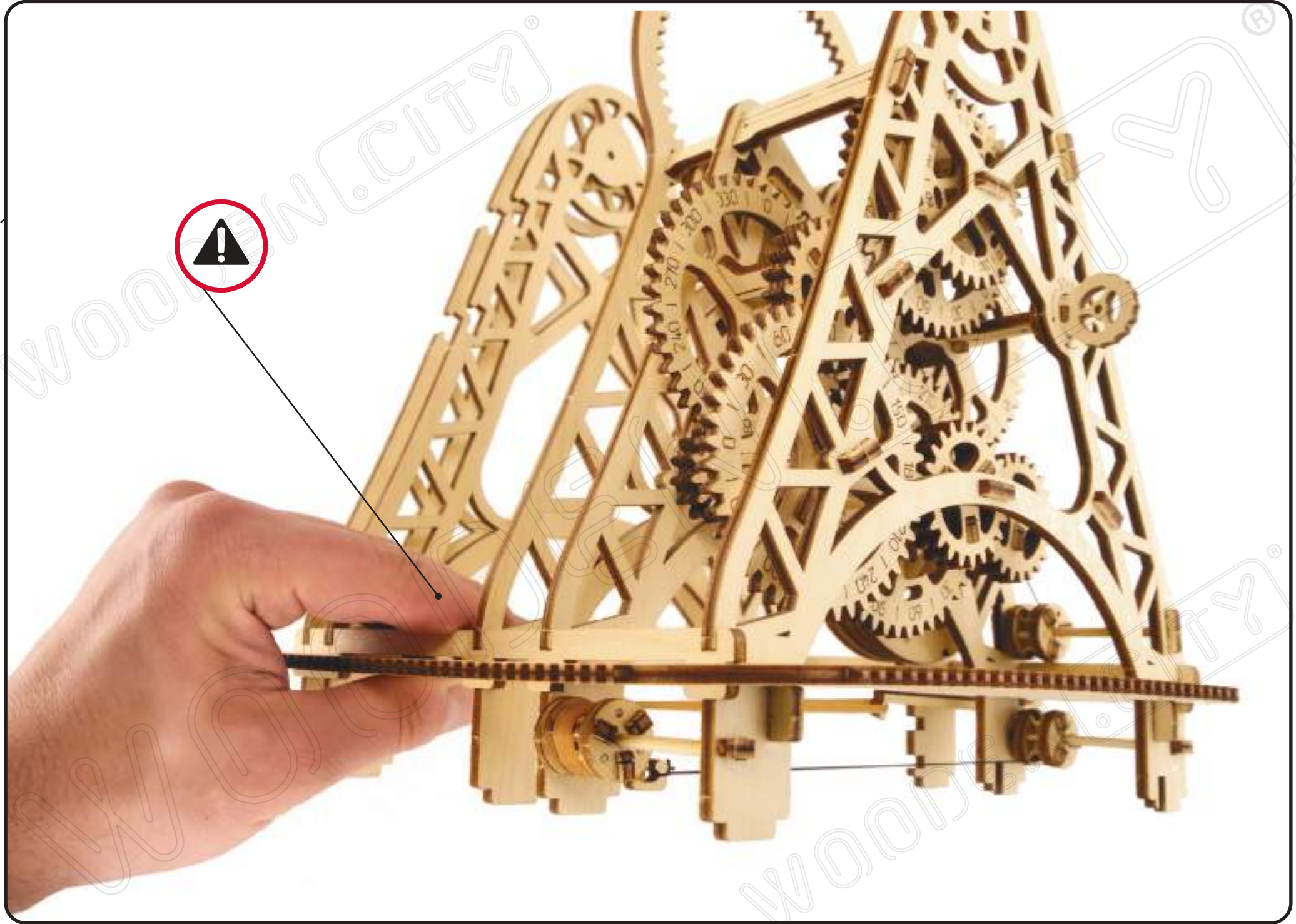

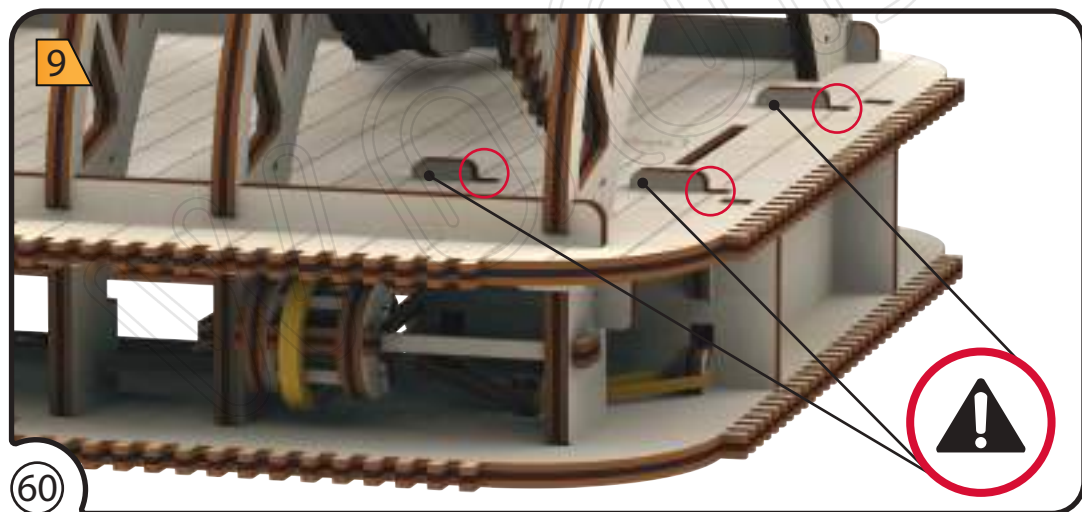
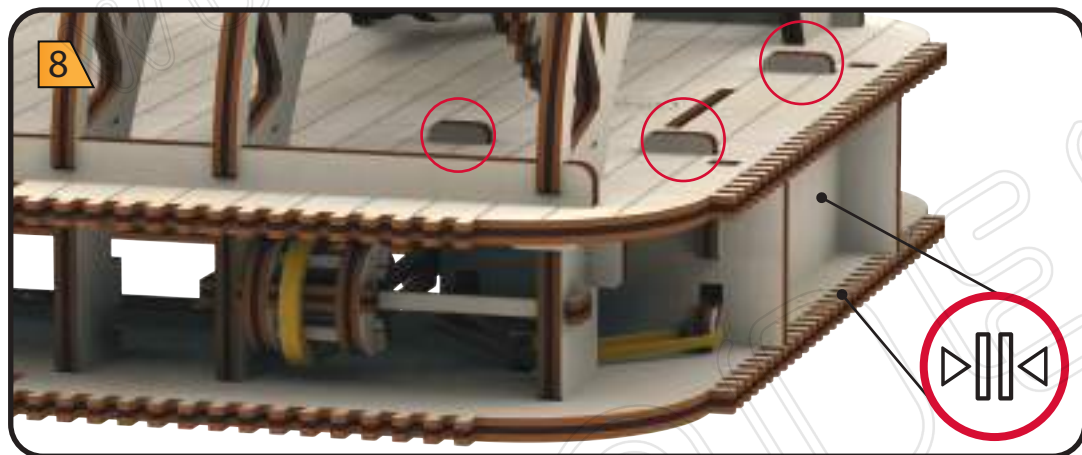
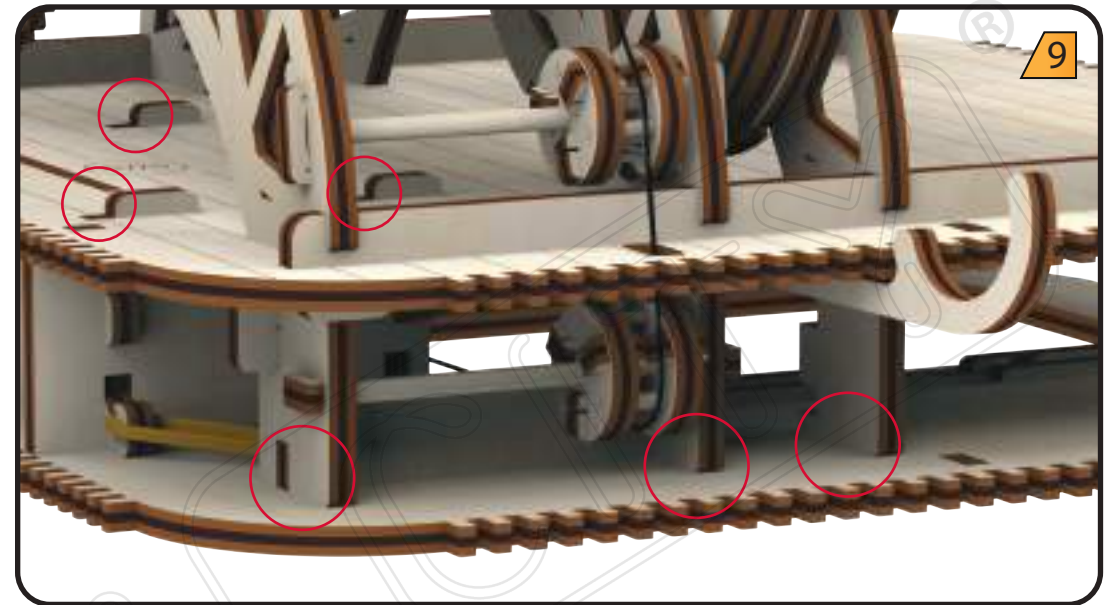
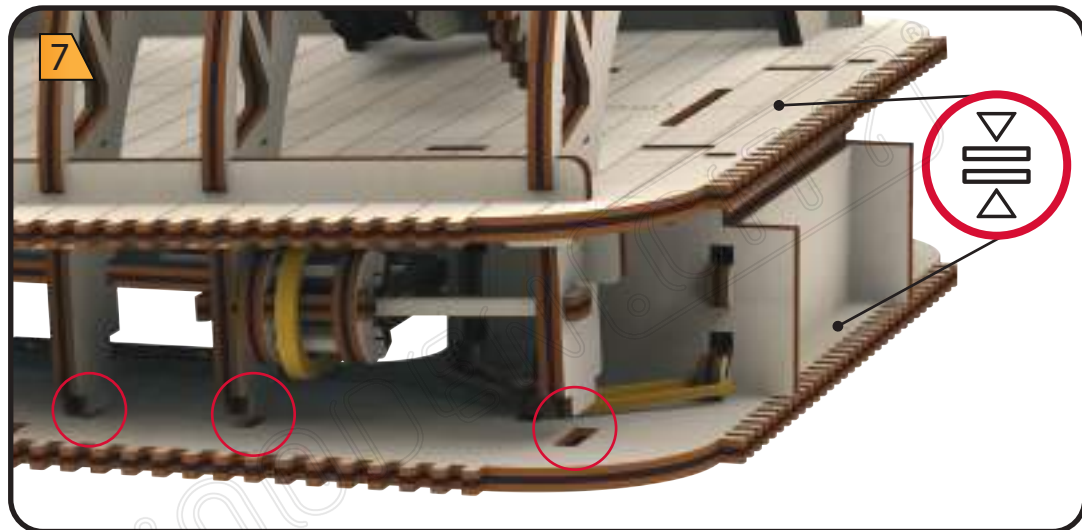

10



11

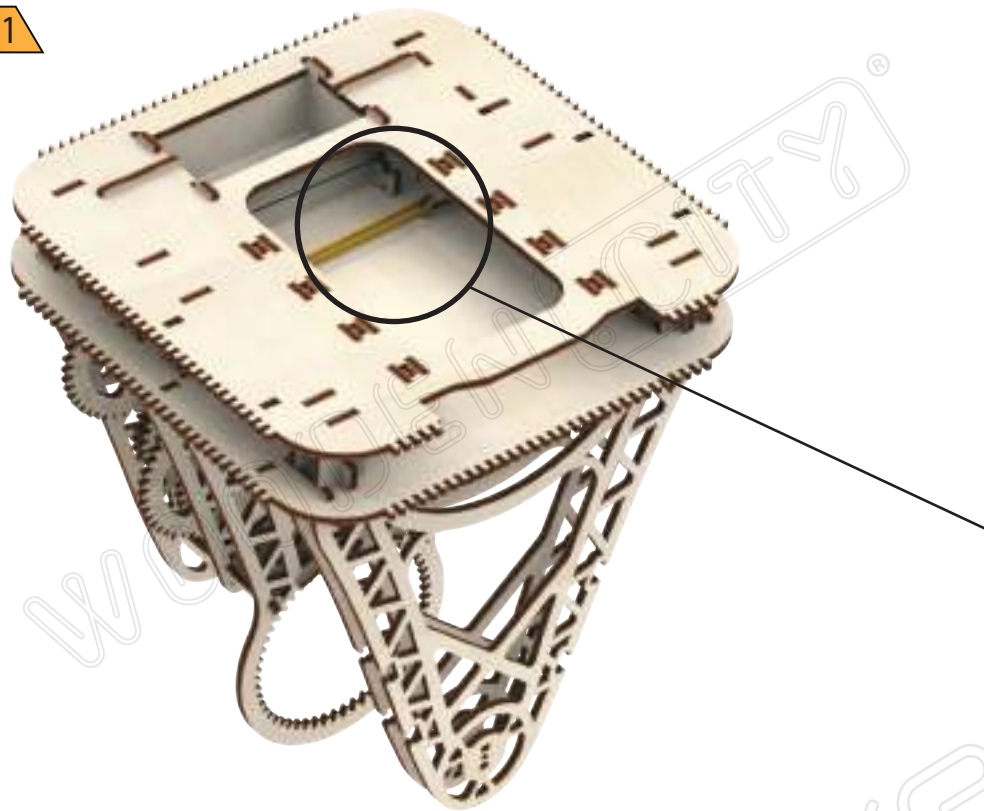

12

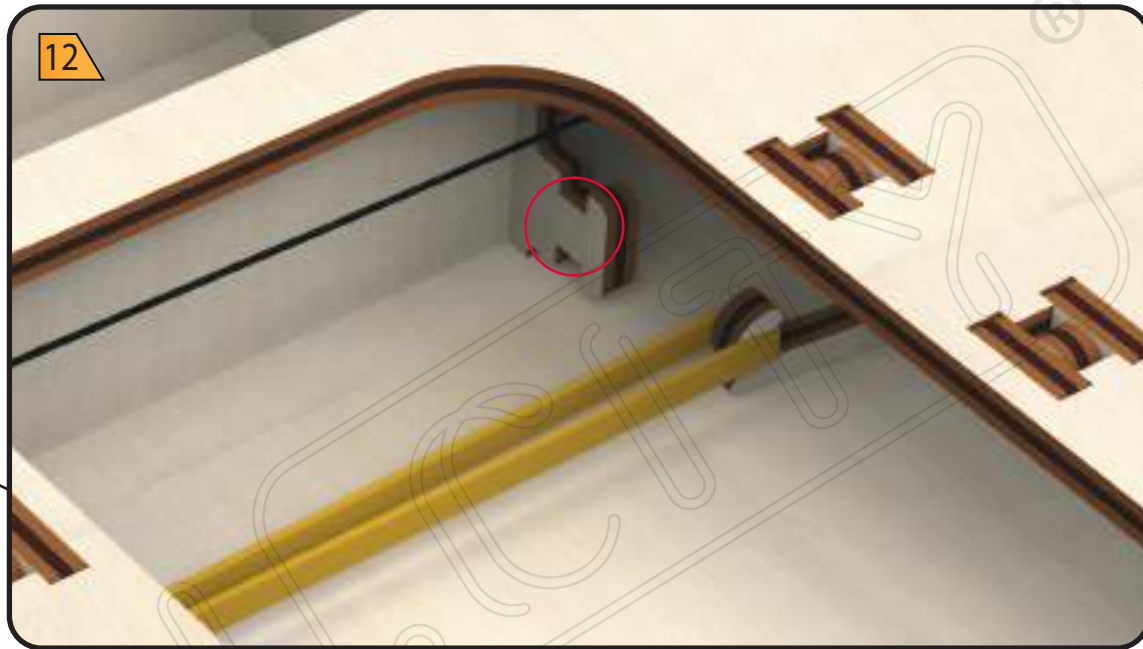

13

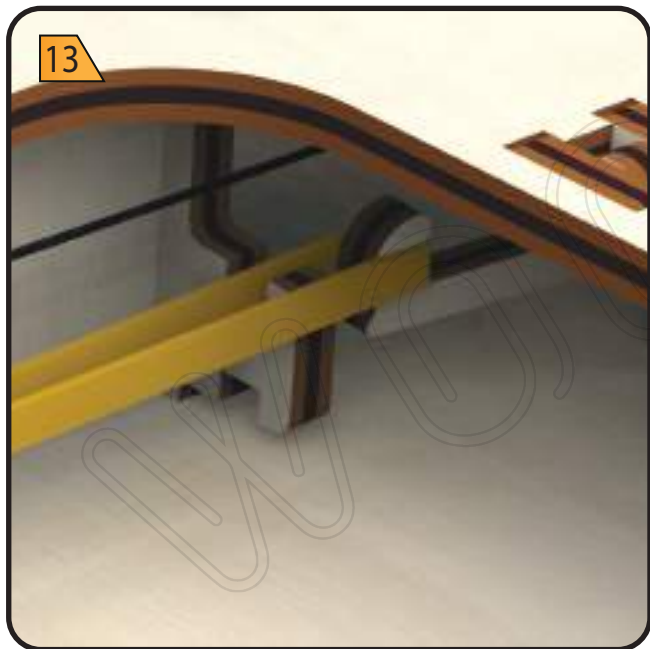

14

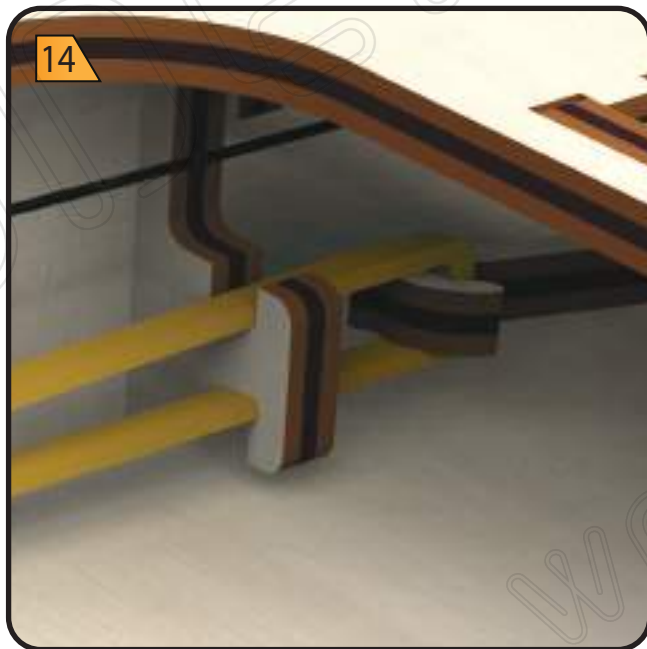

15

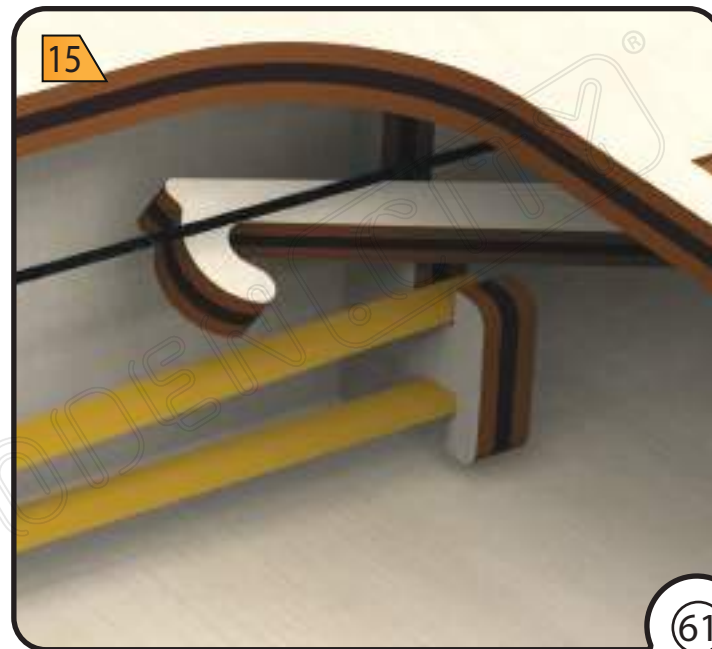

16

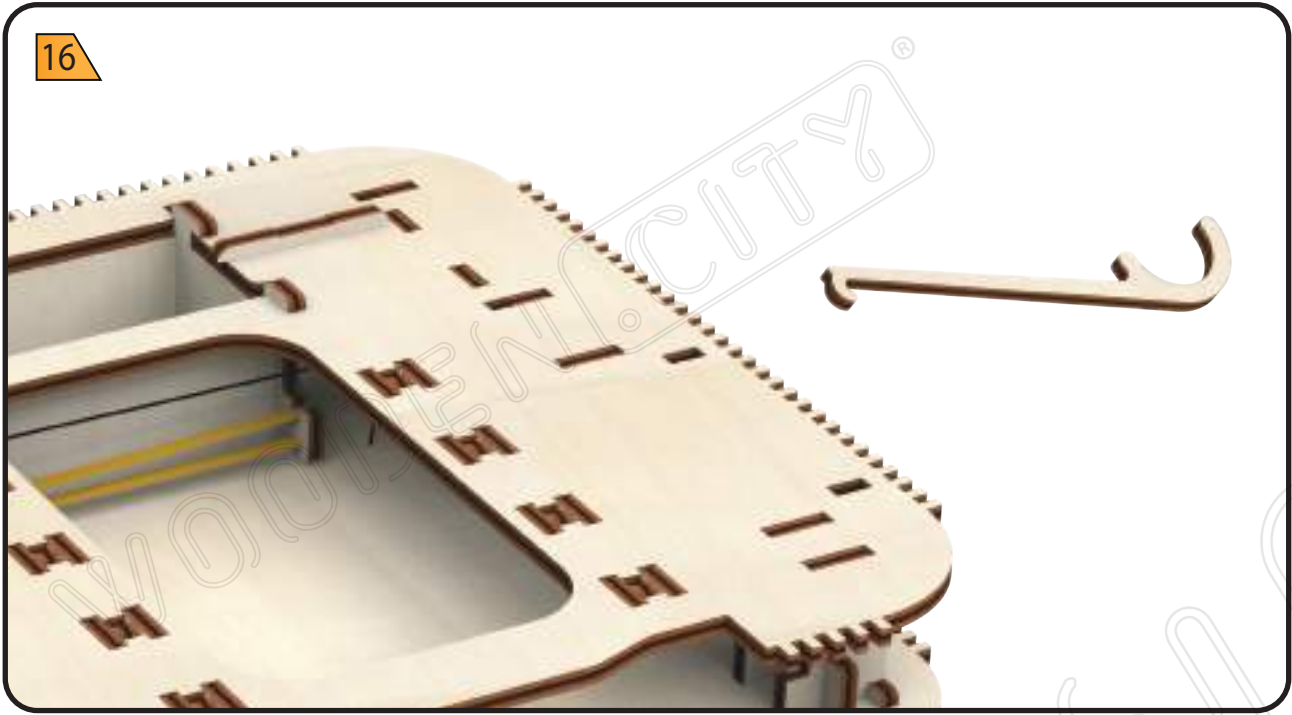

17

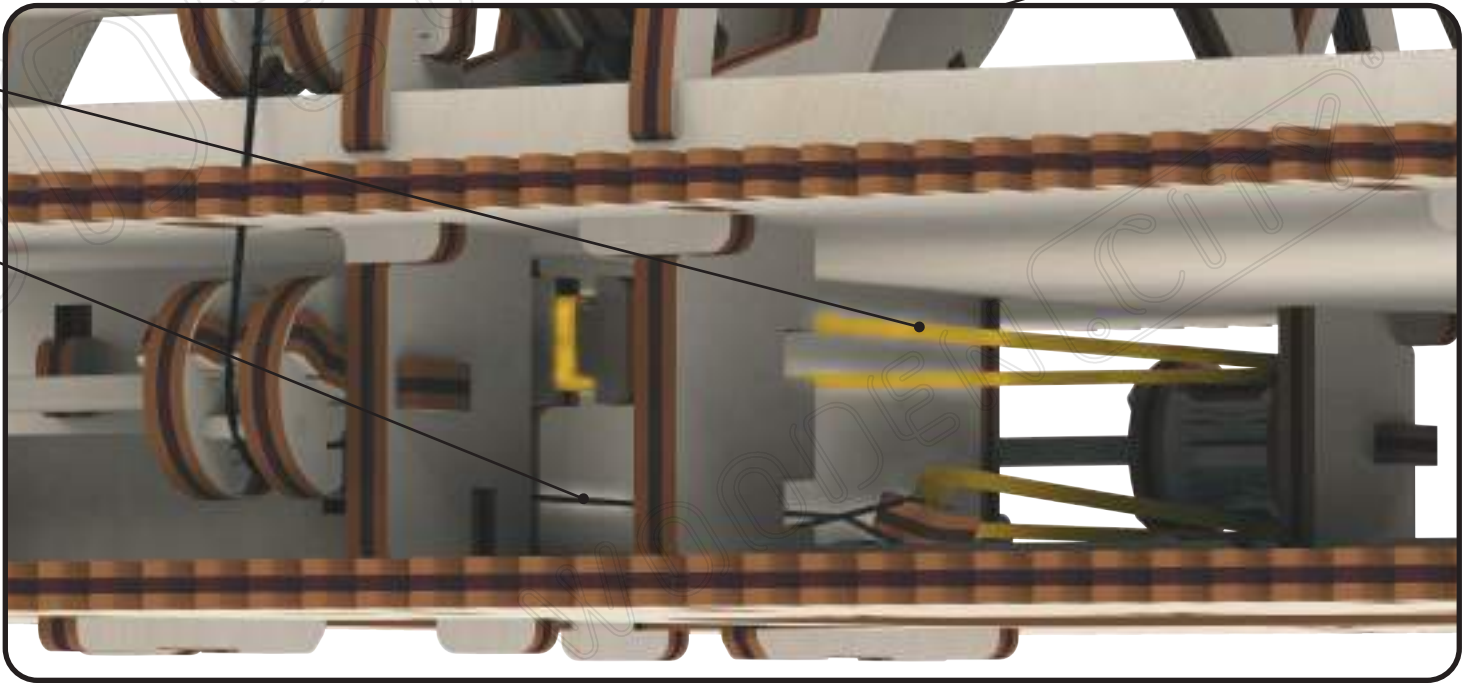

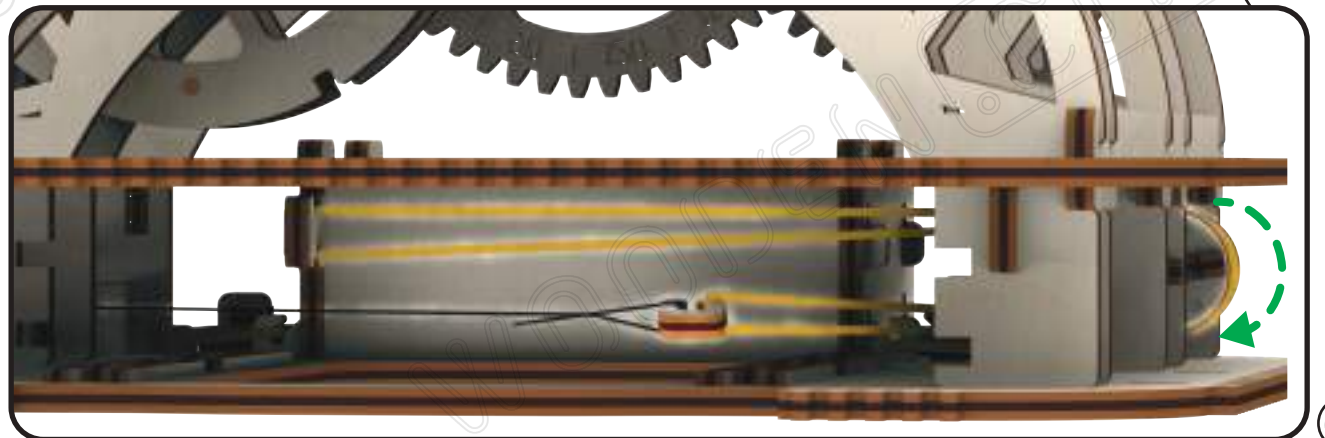
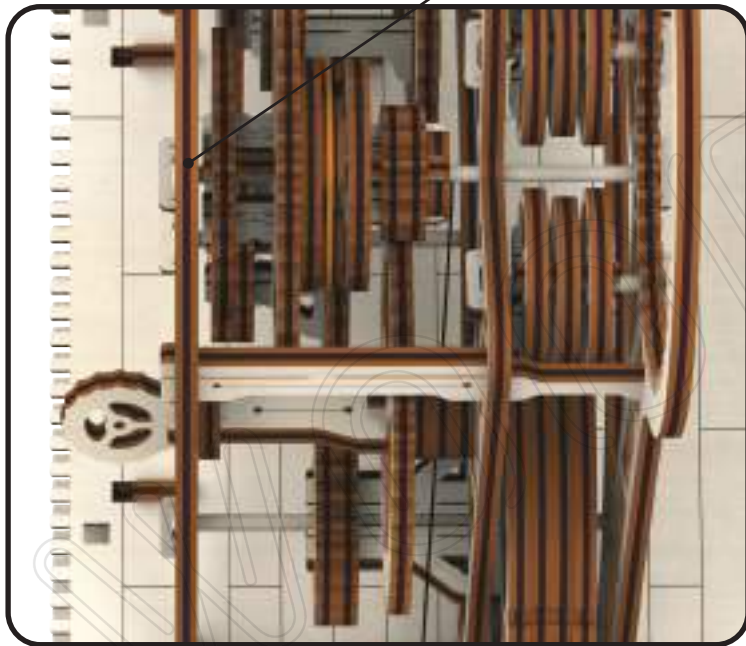
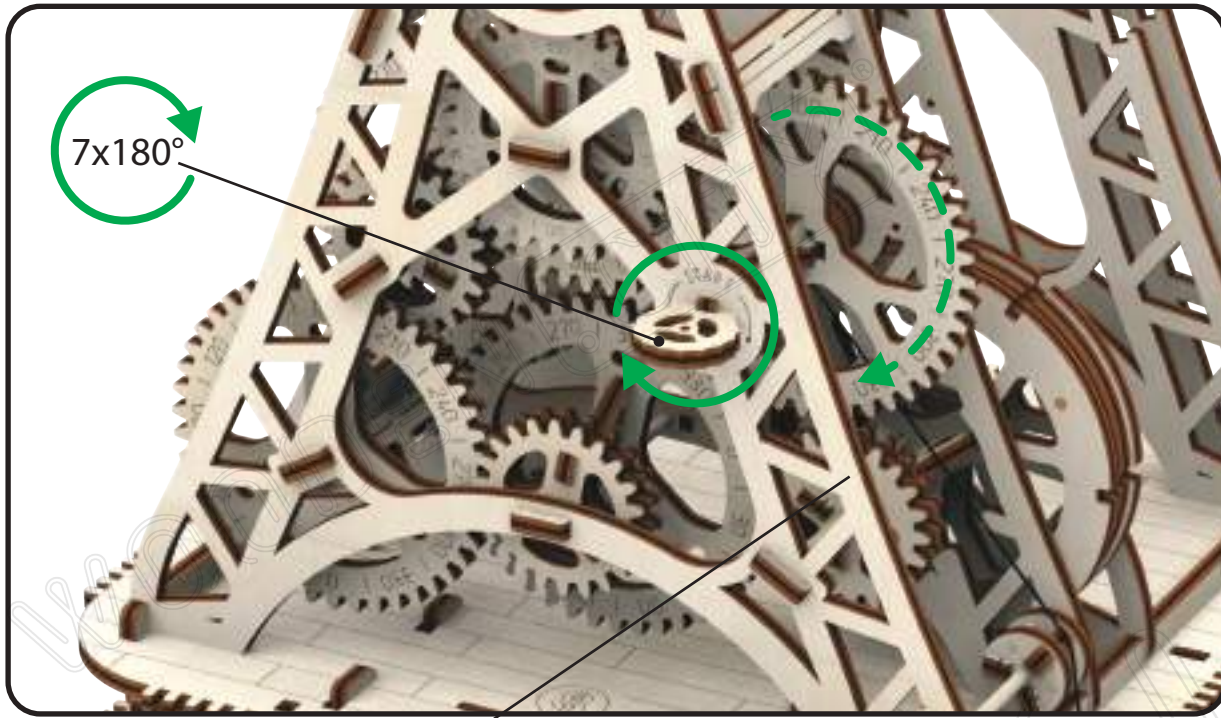

2



1

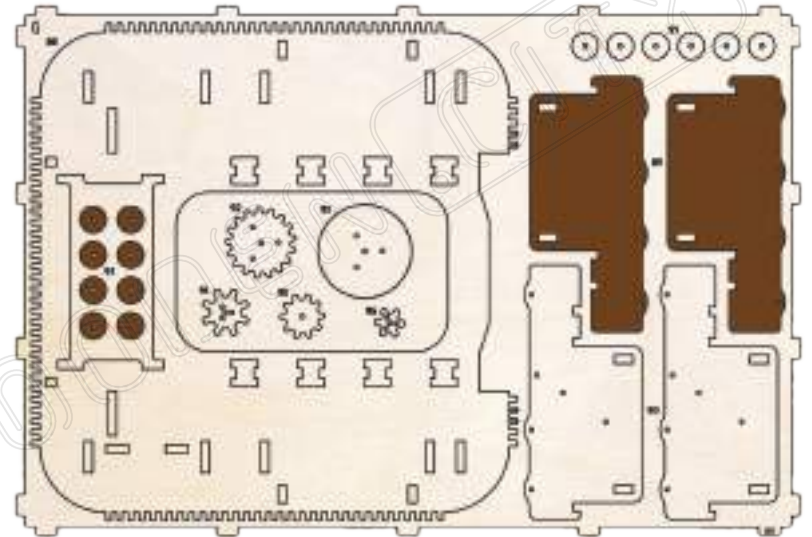

2



3



4

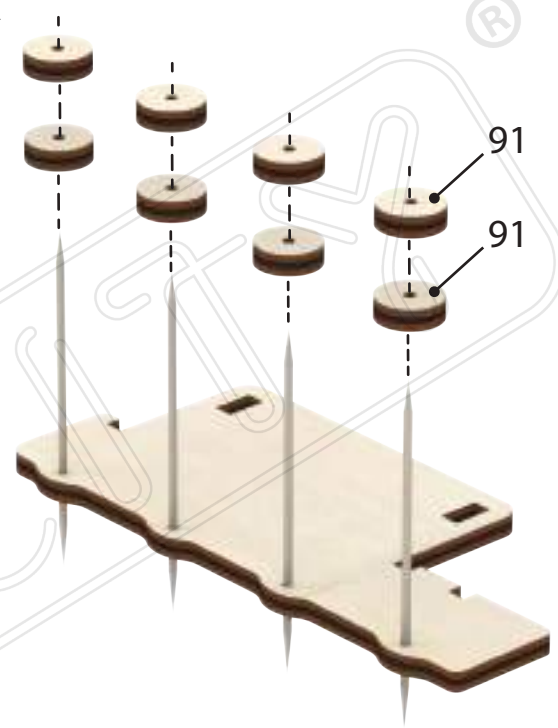

5

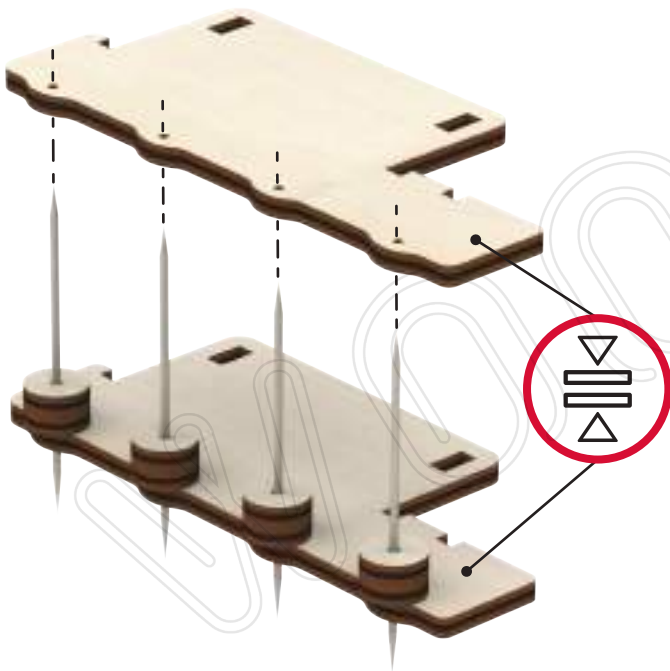

6

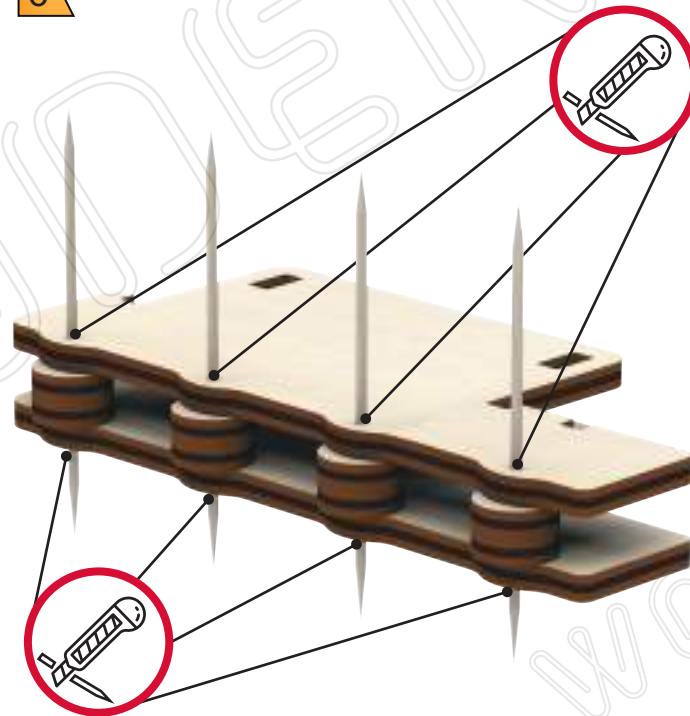

7

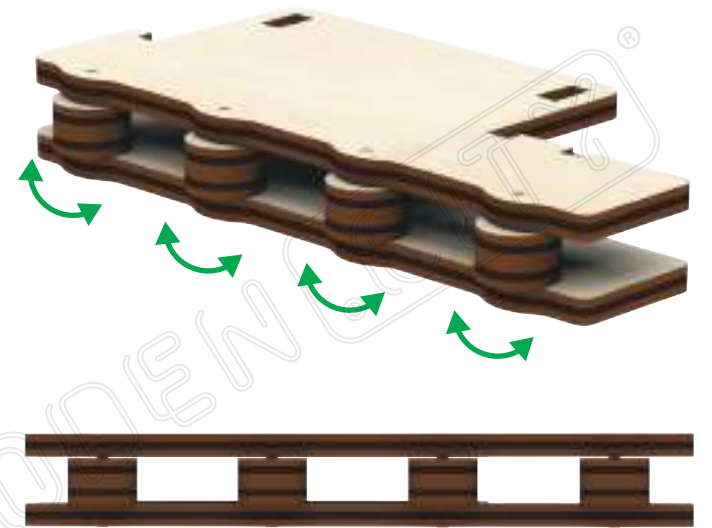

1

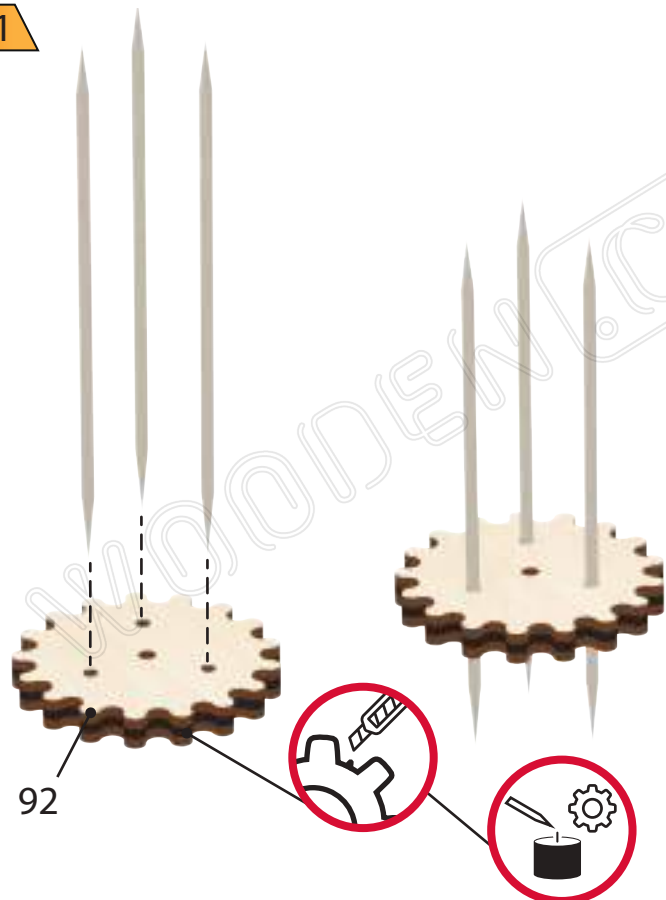

2

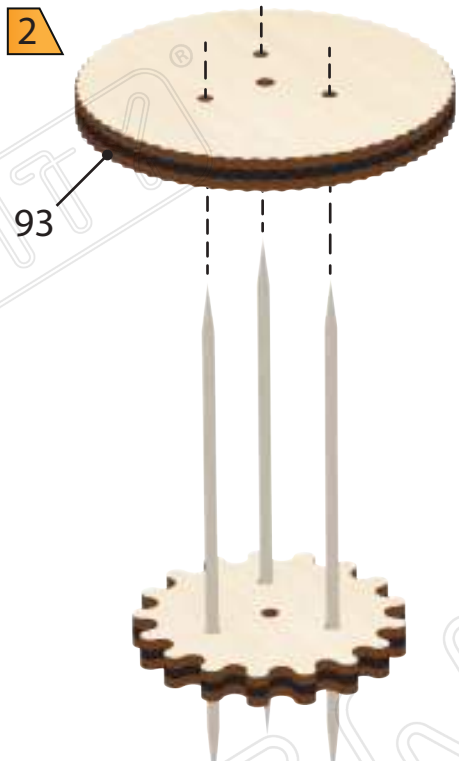

3



4

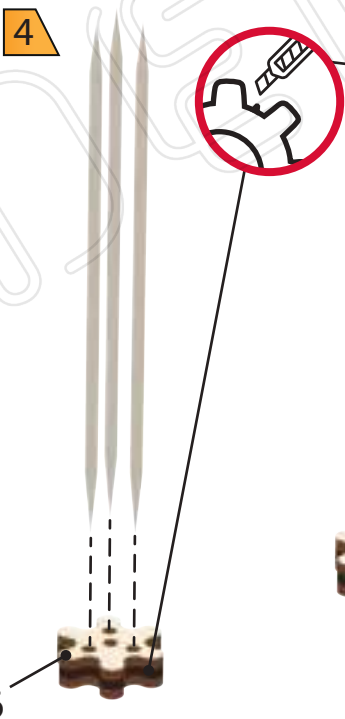

5



6

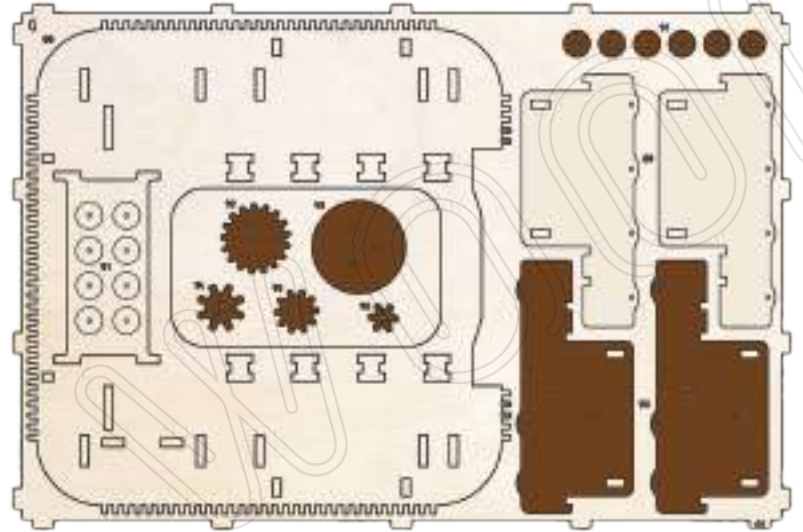
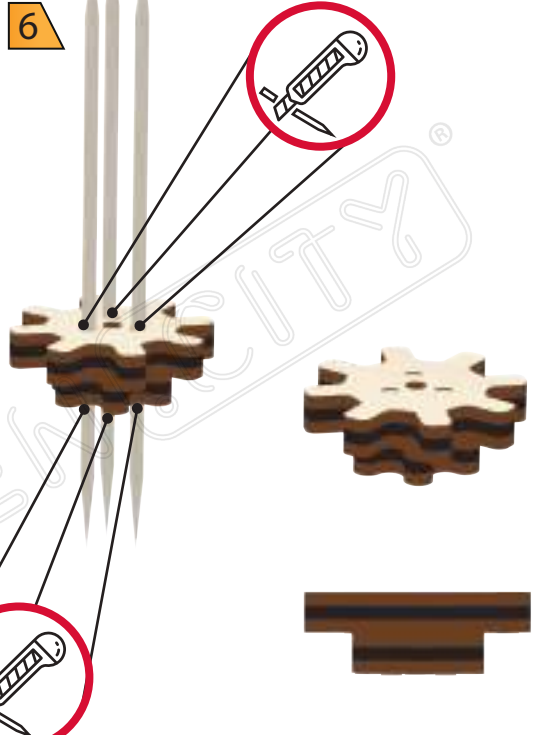

7

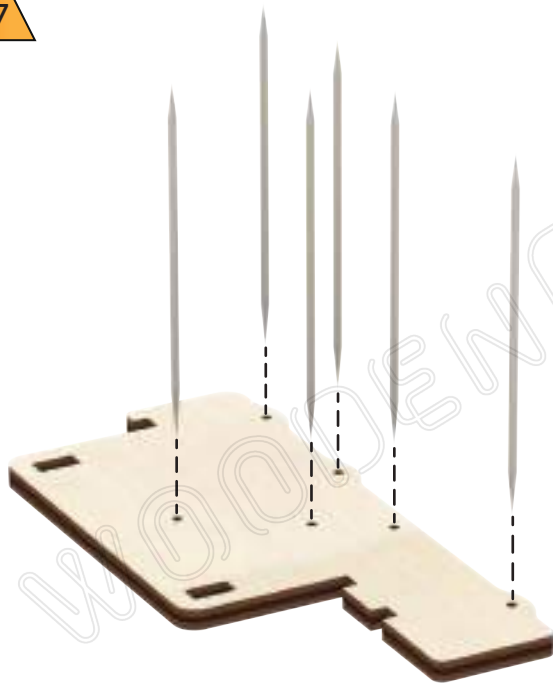

8

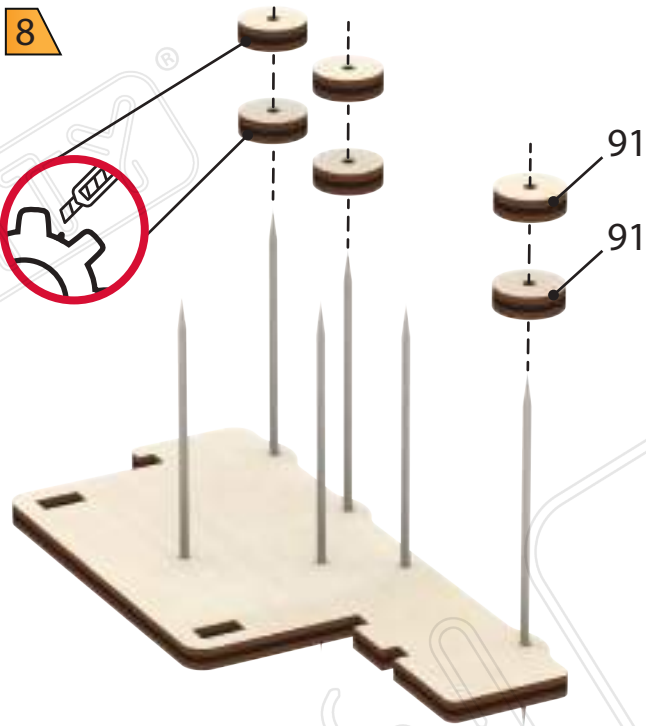

9

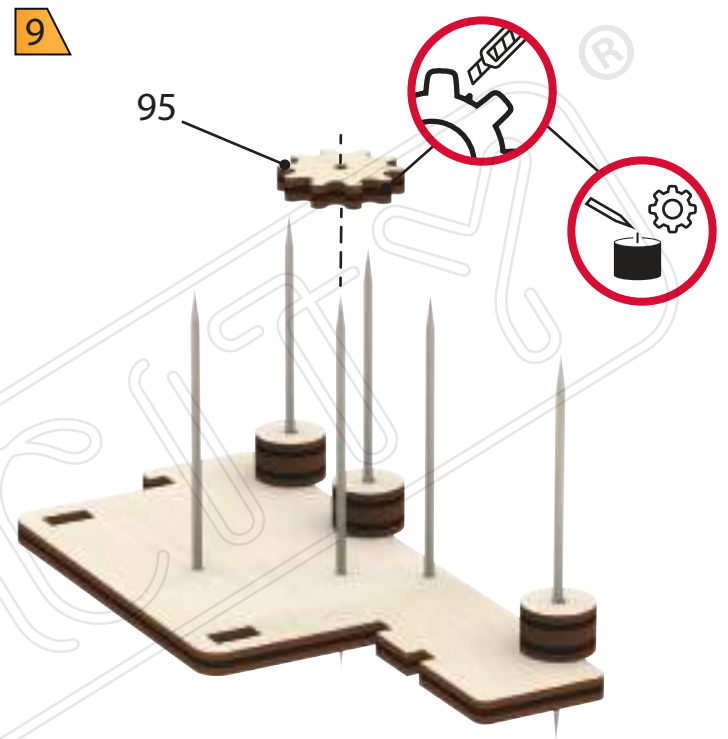

10

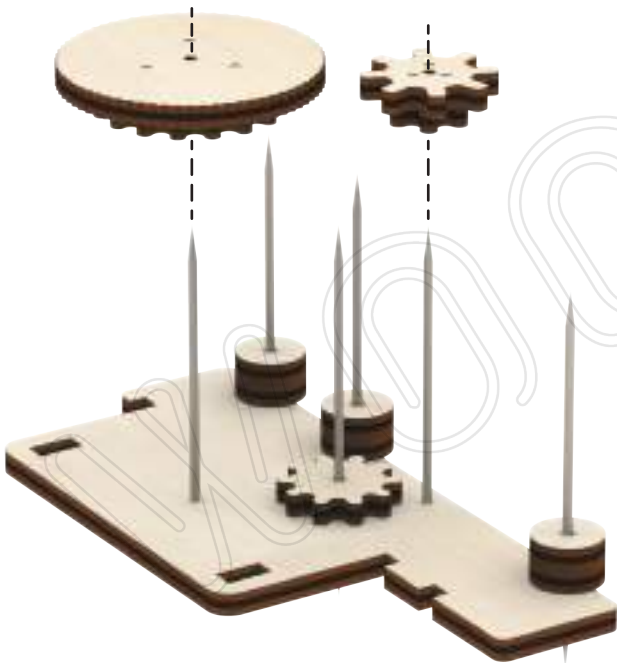

11

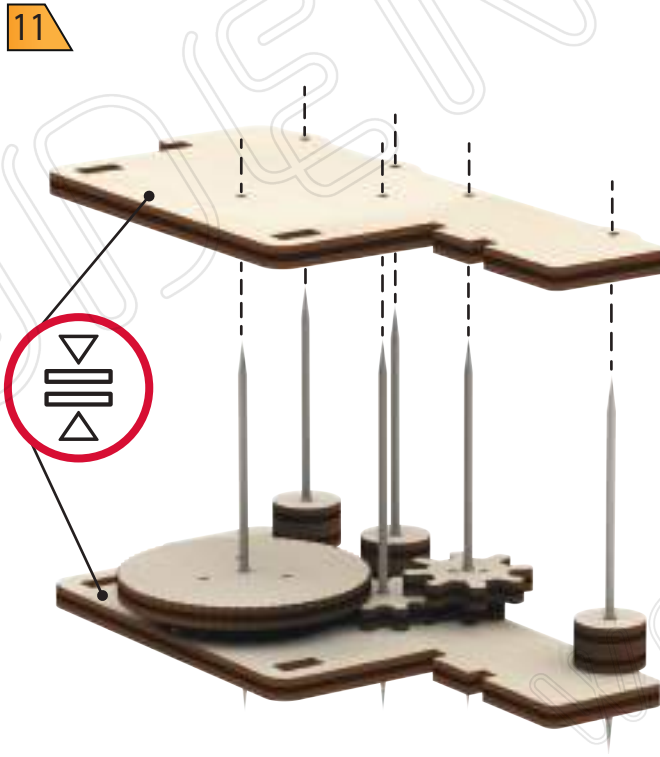

12

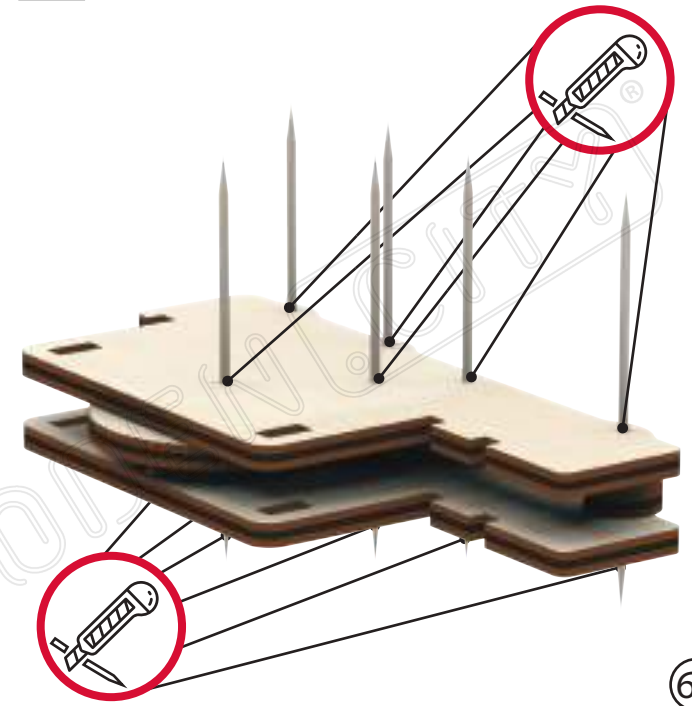



13

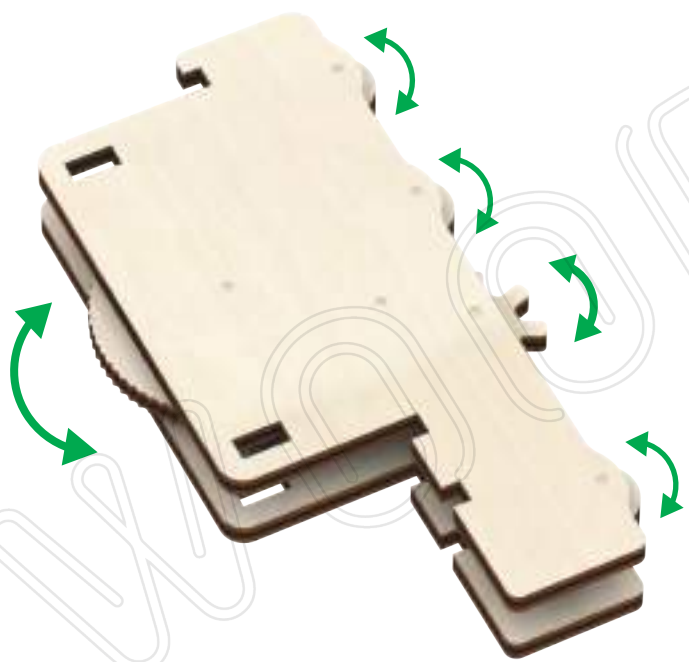

14

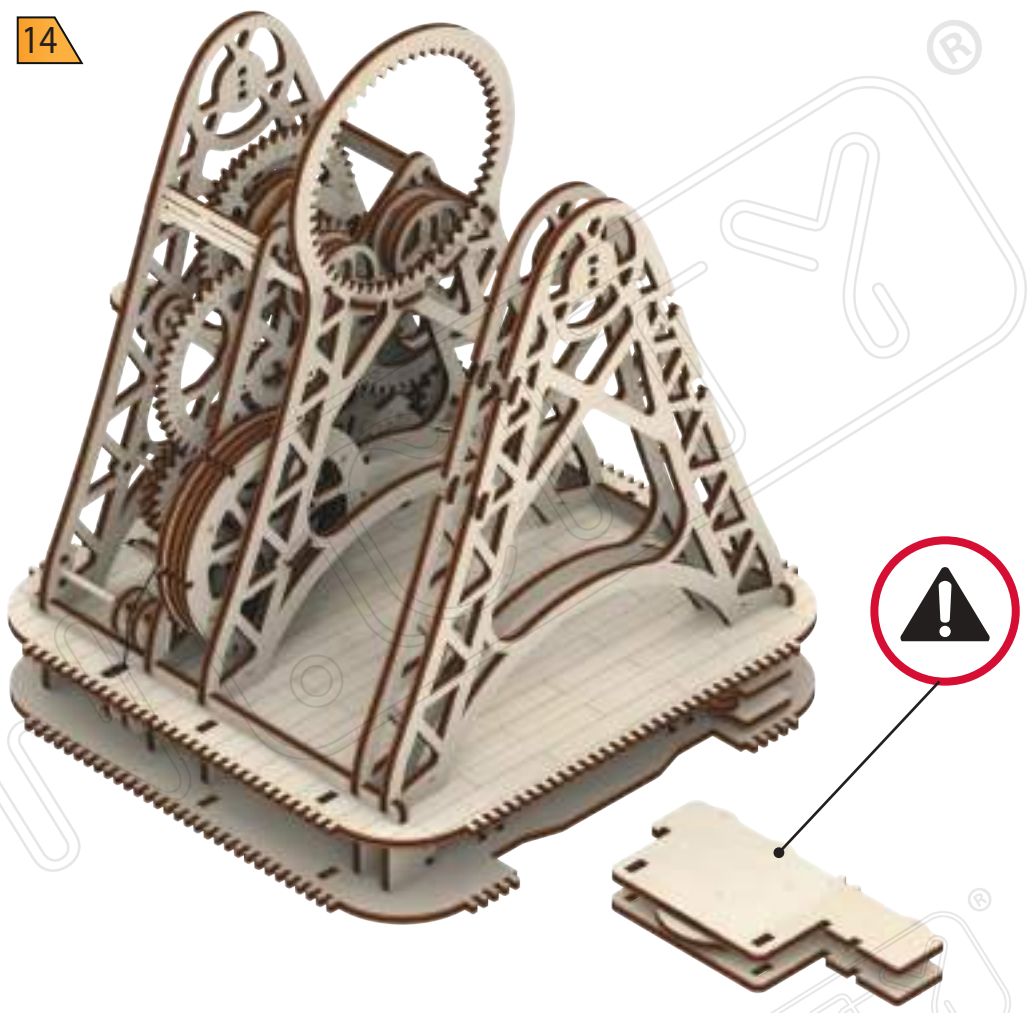

15

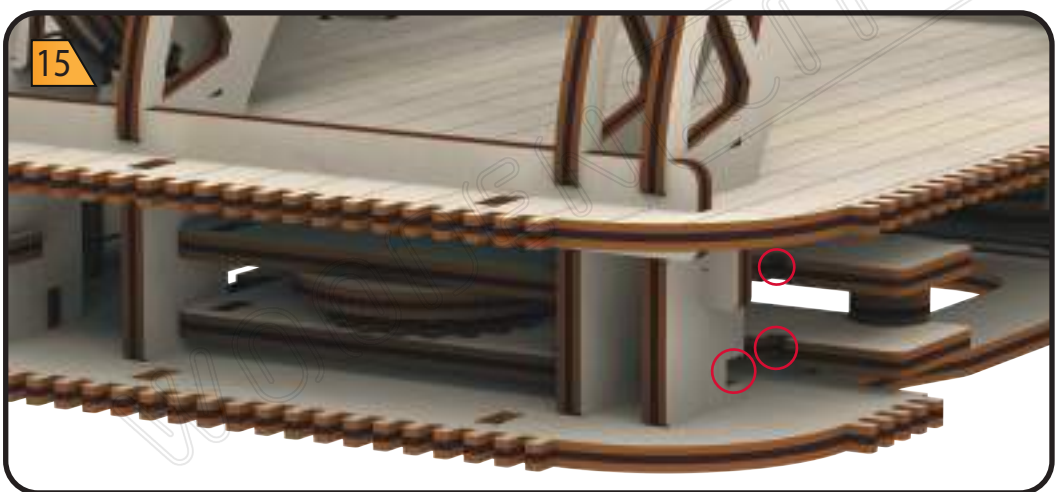

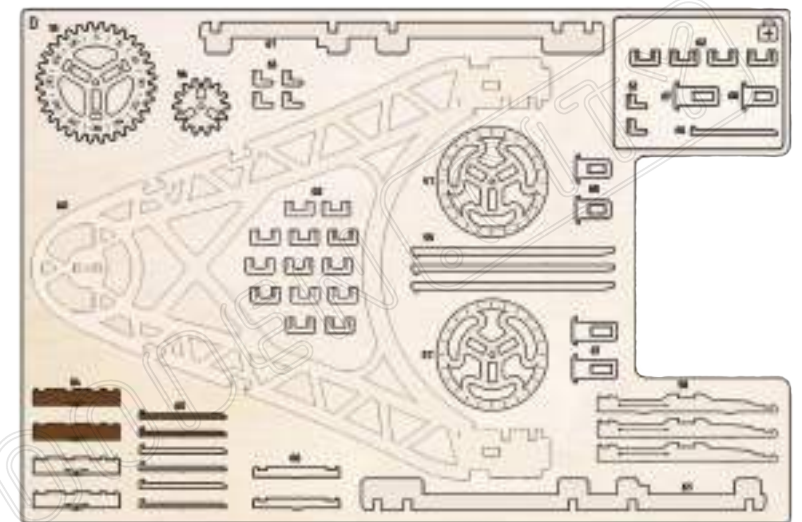
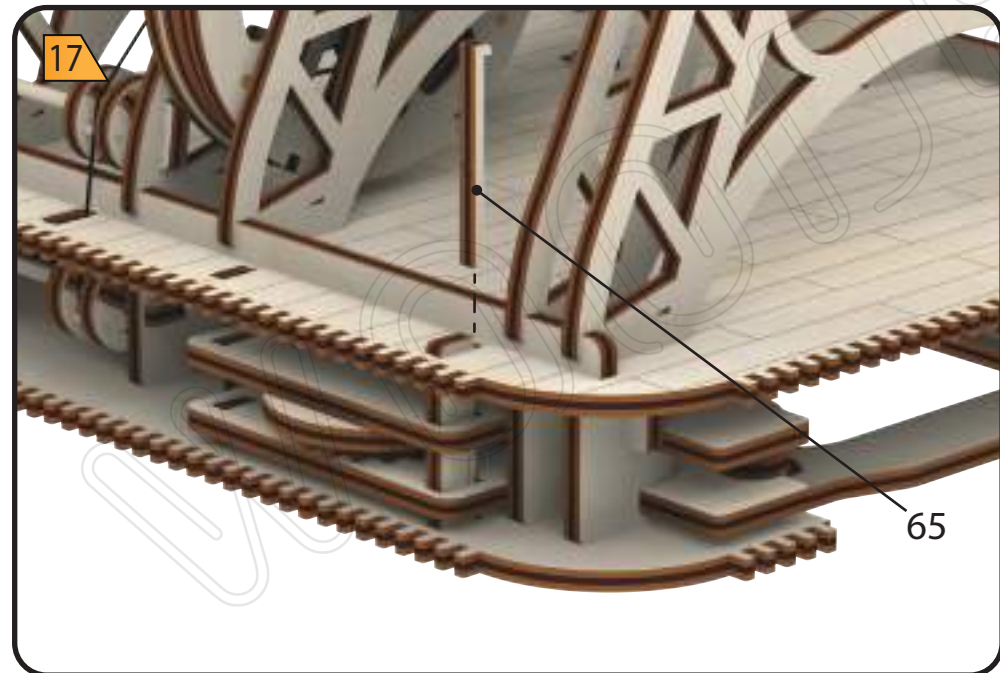
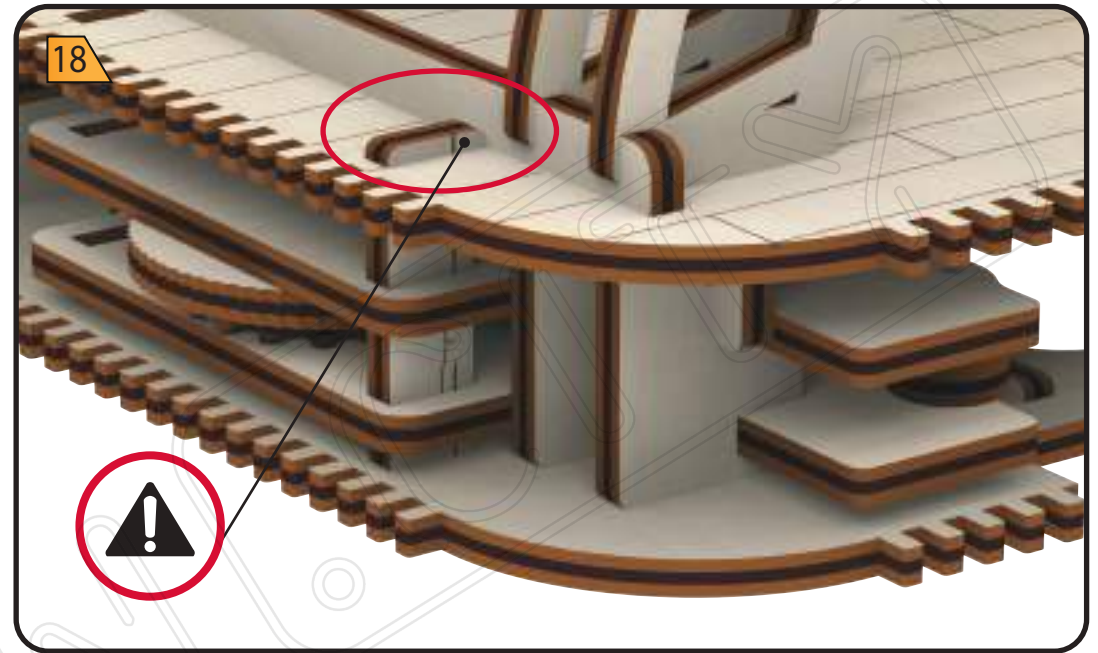
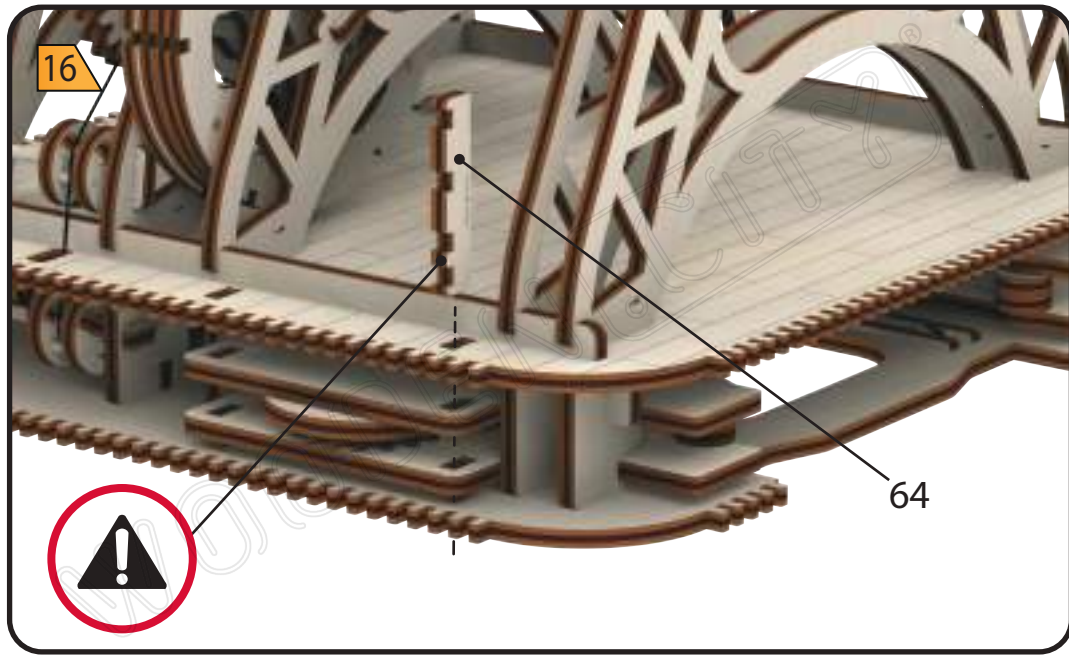

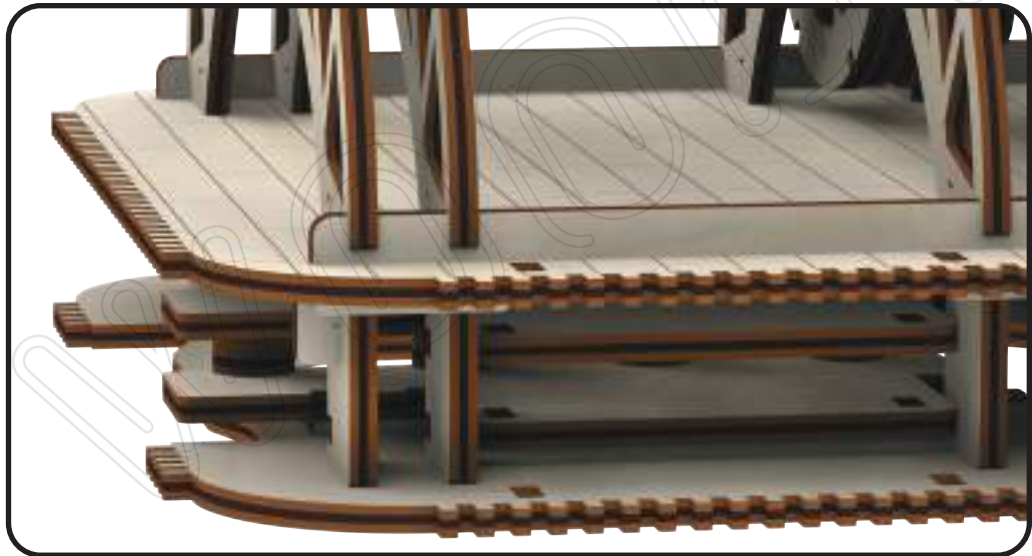
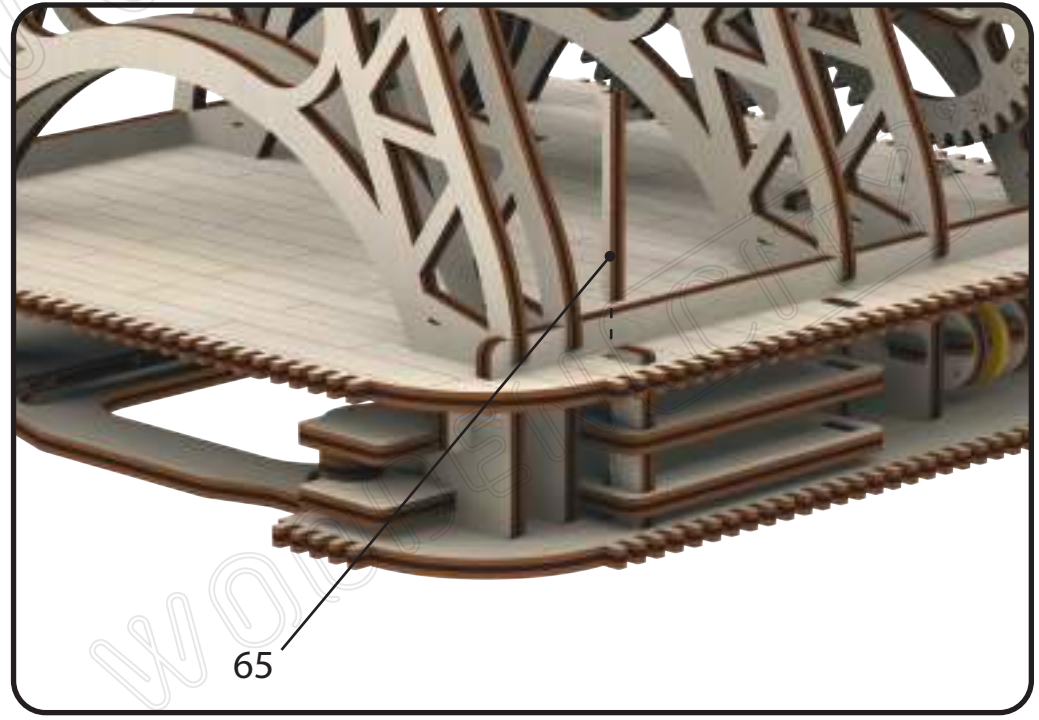
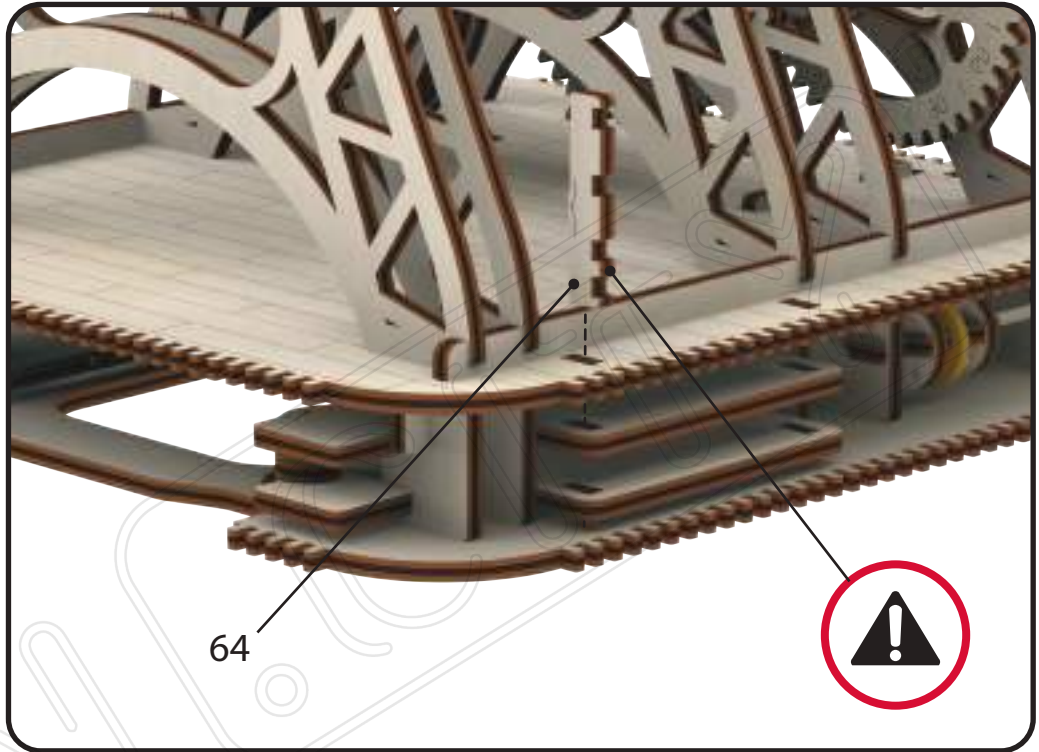
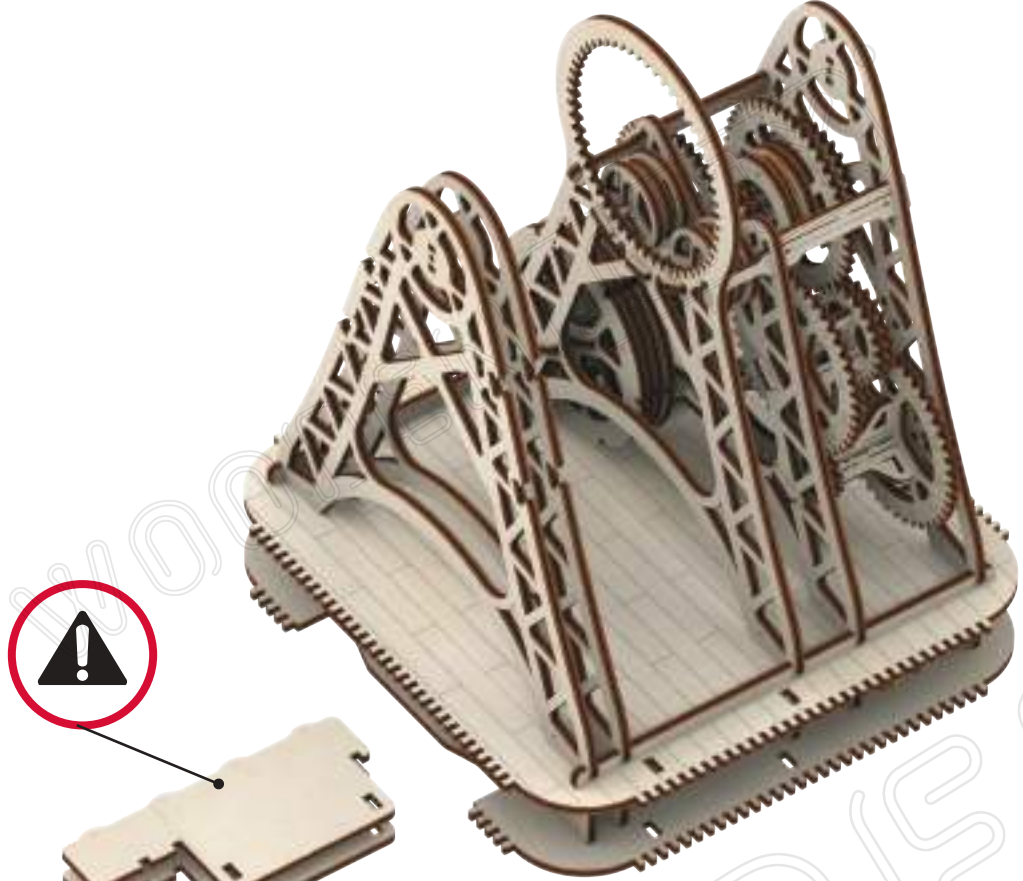

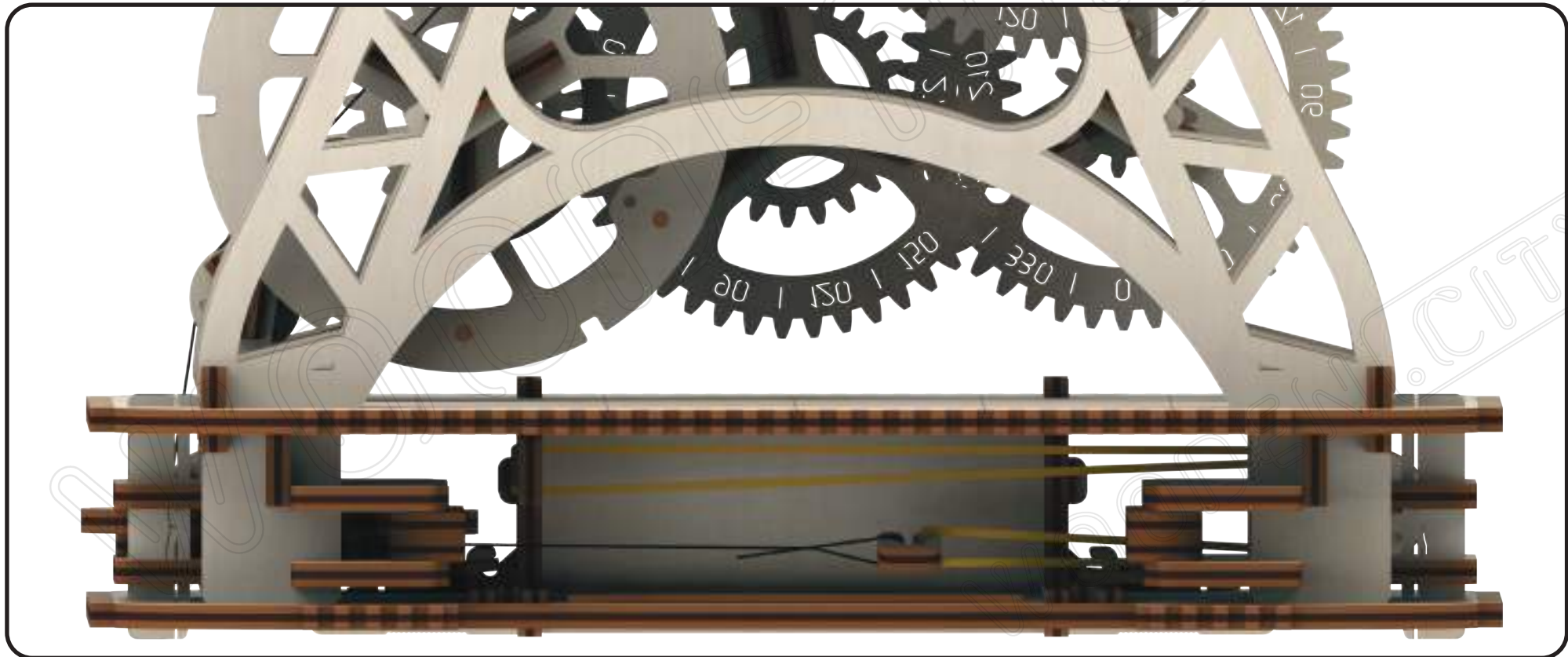
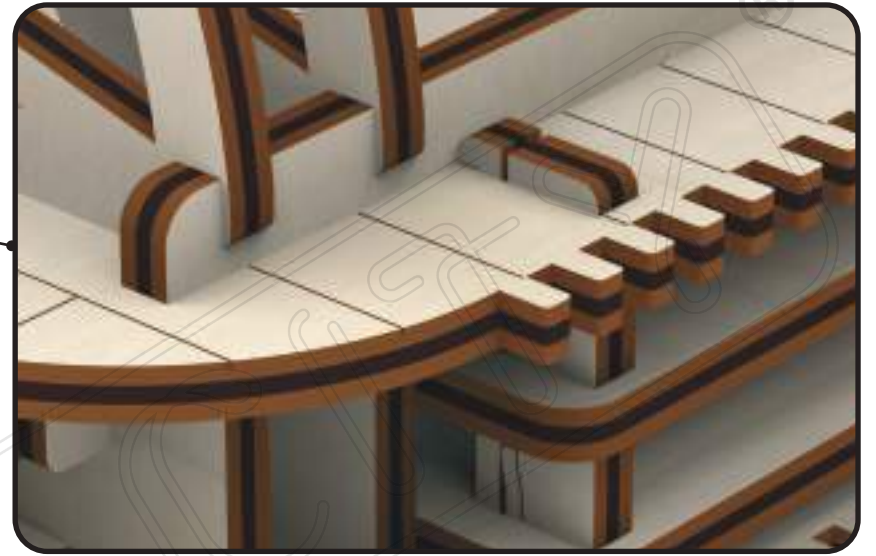
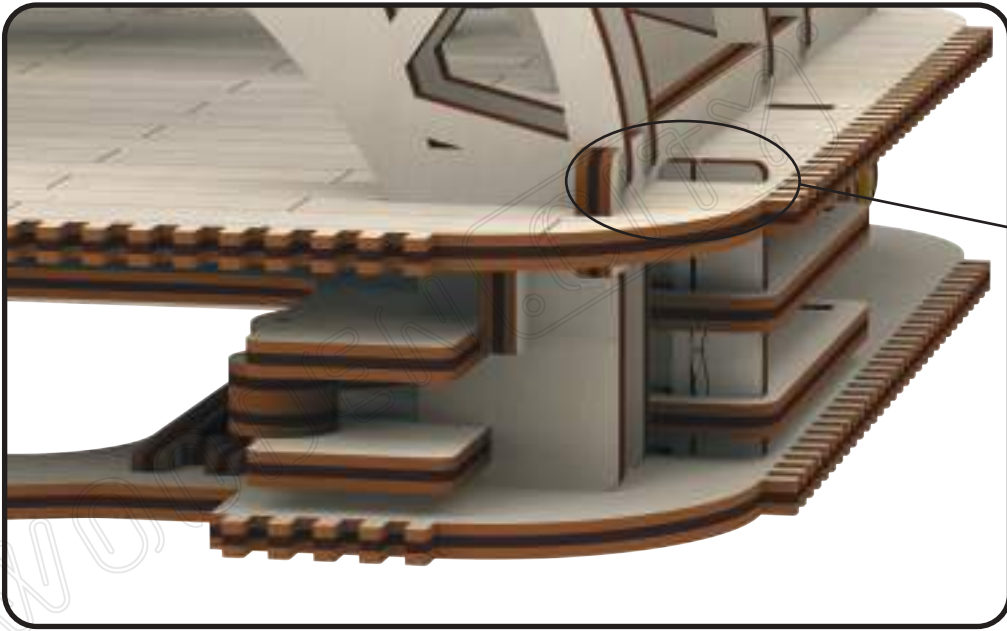

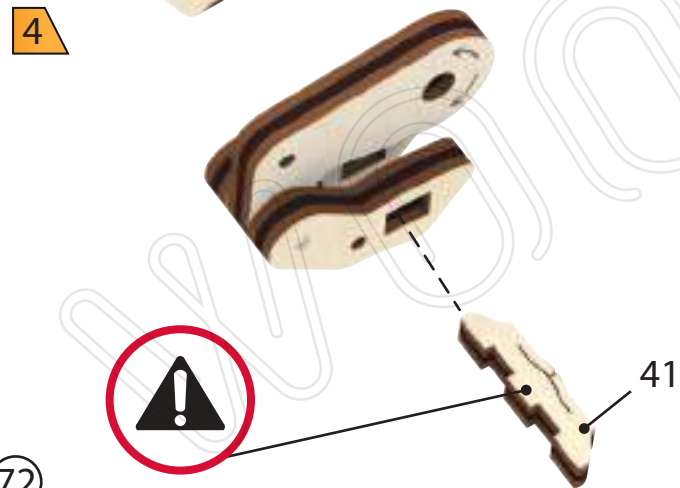
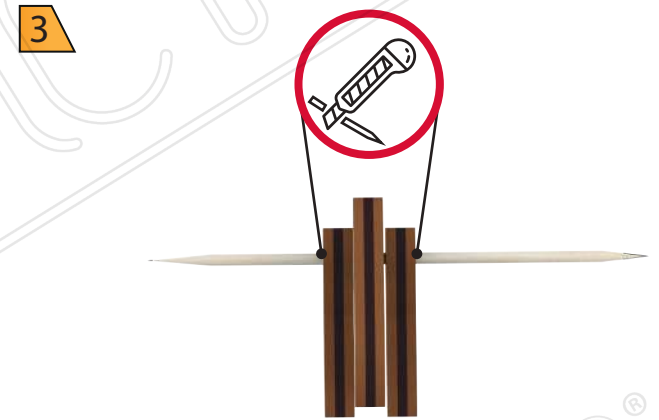
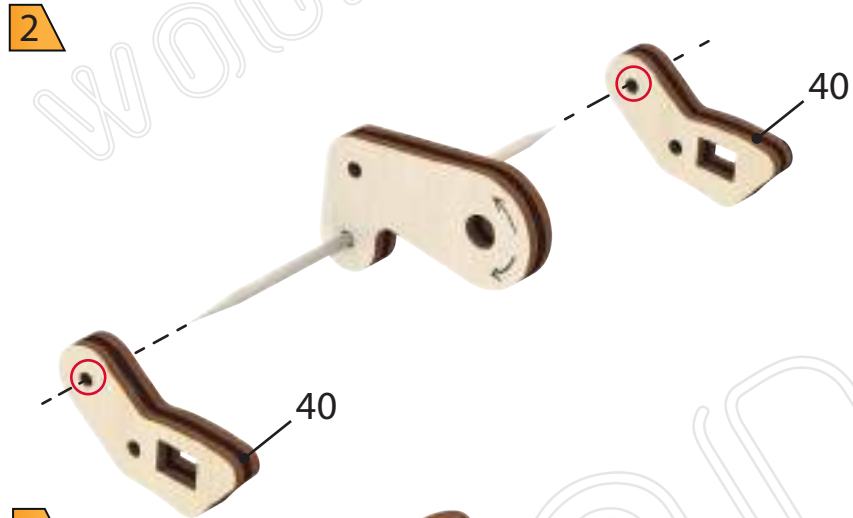
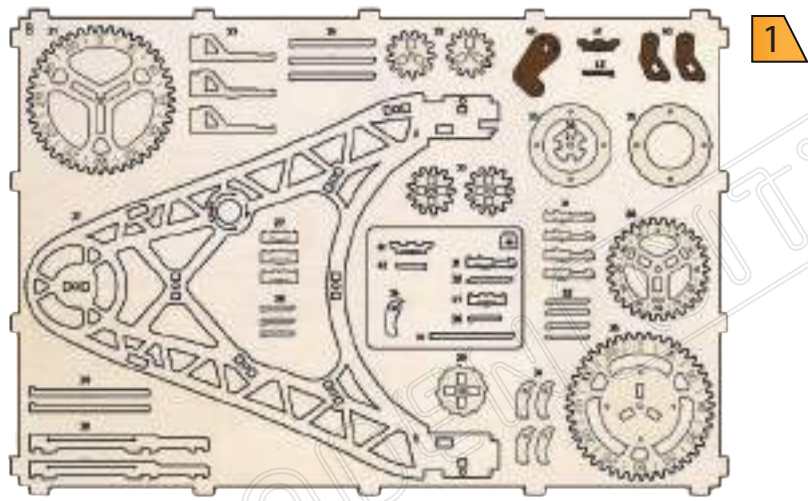

6



7

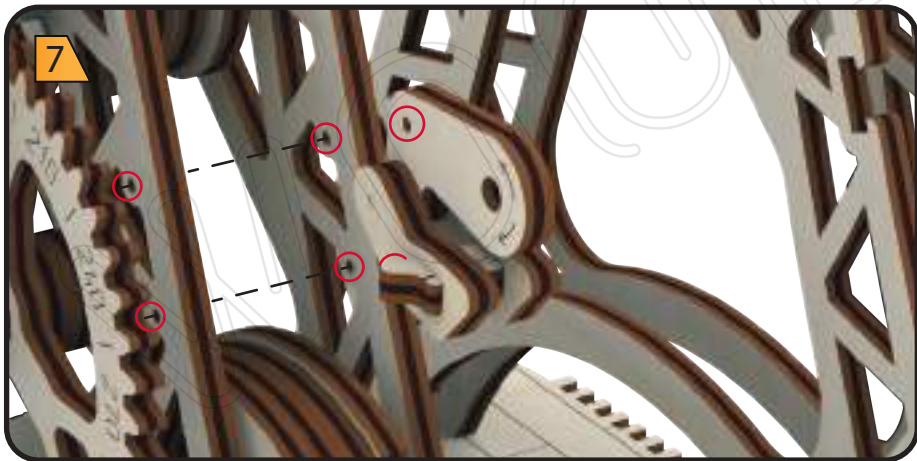

8

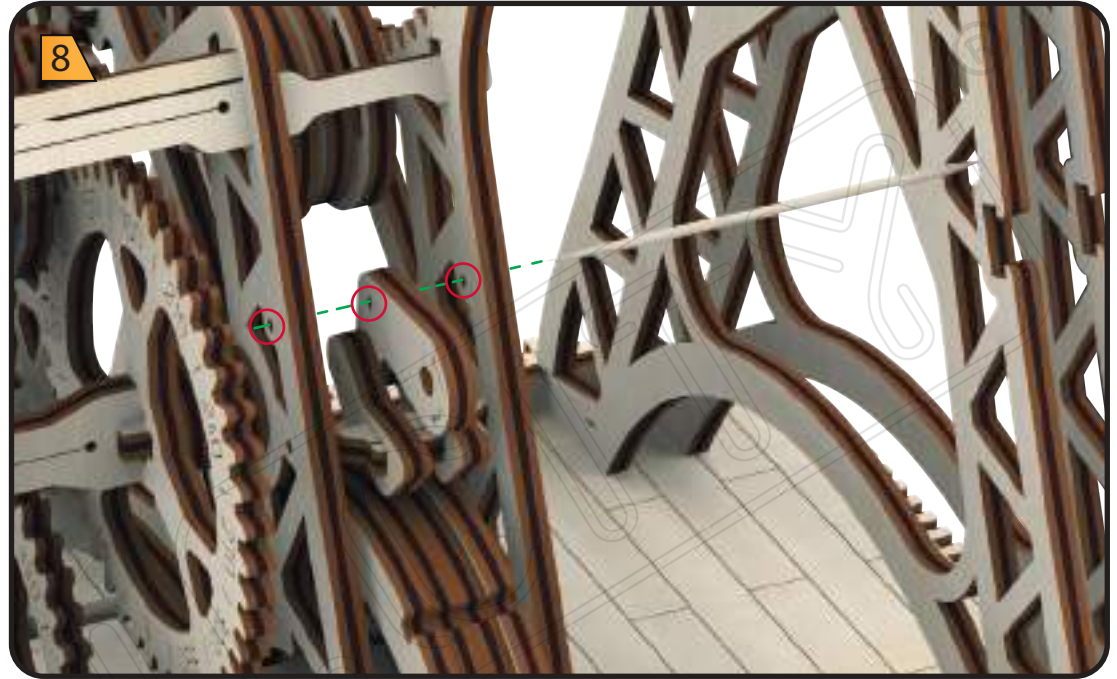

9

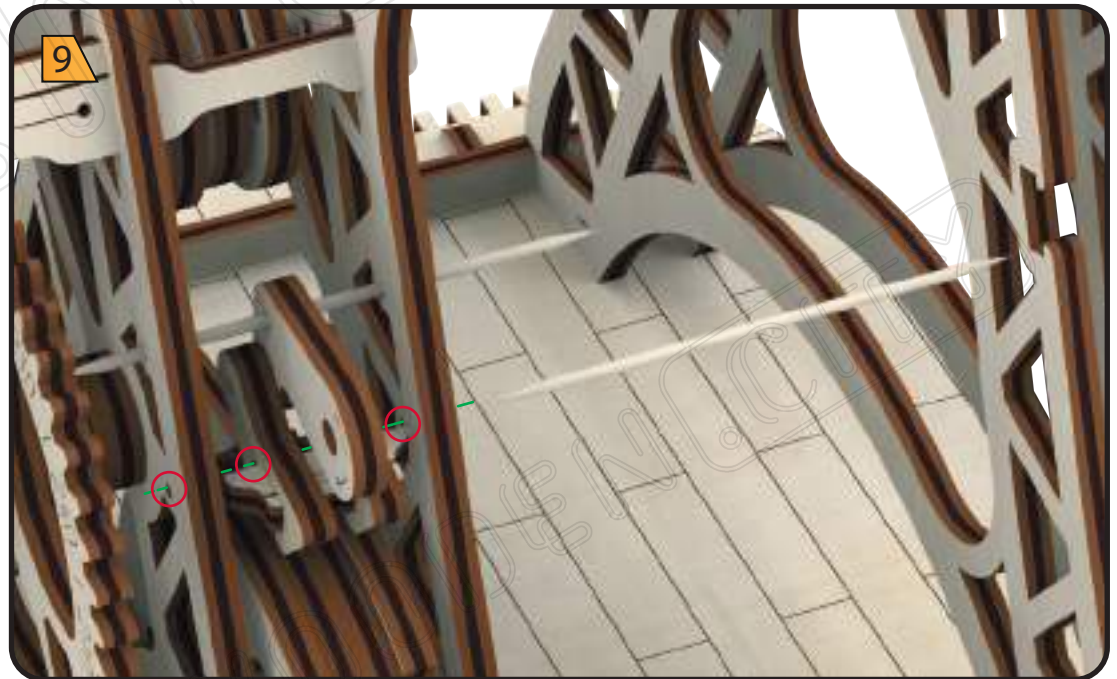

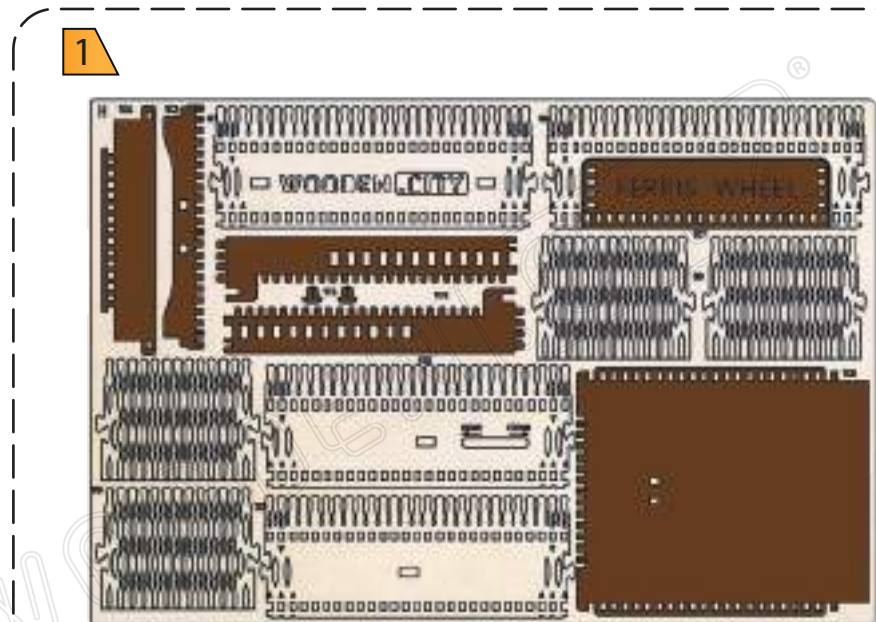
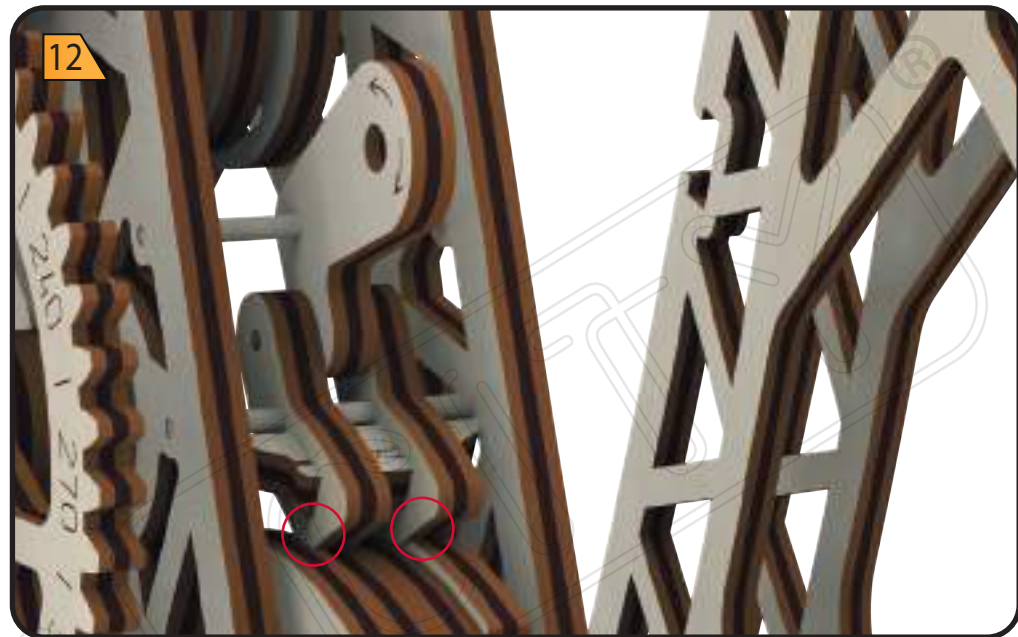
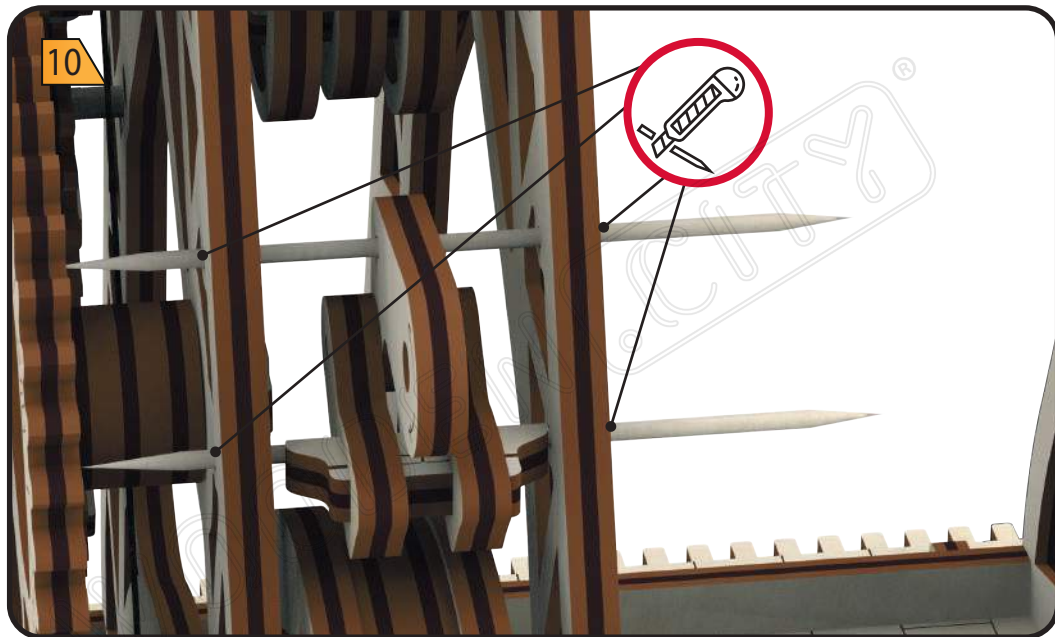

2

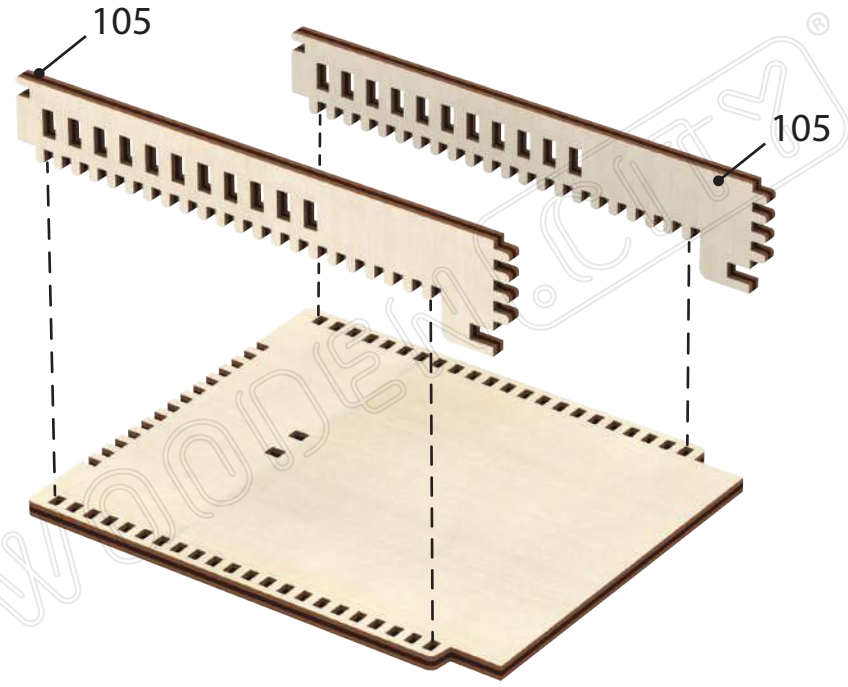

3

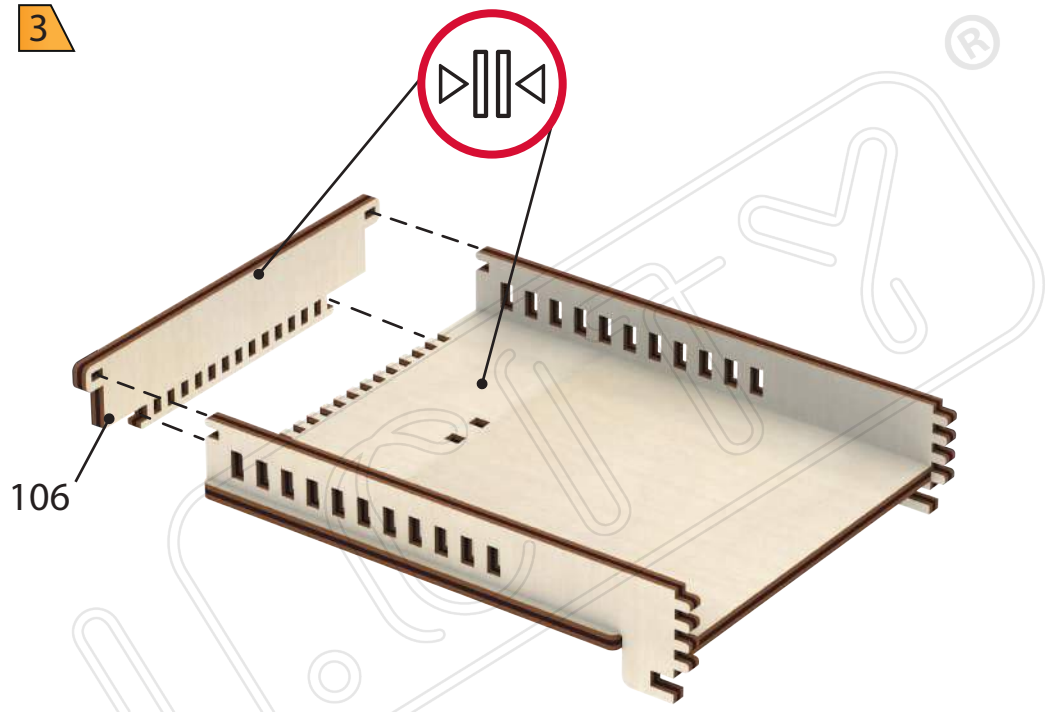

4

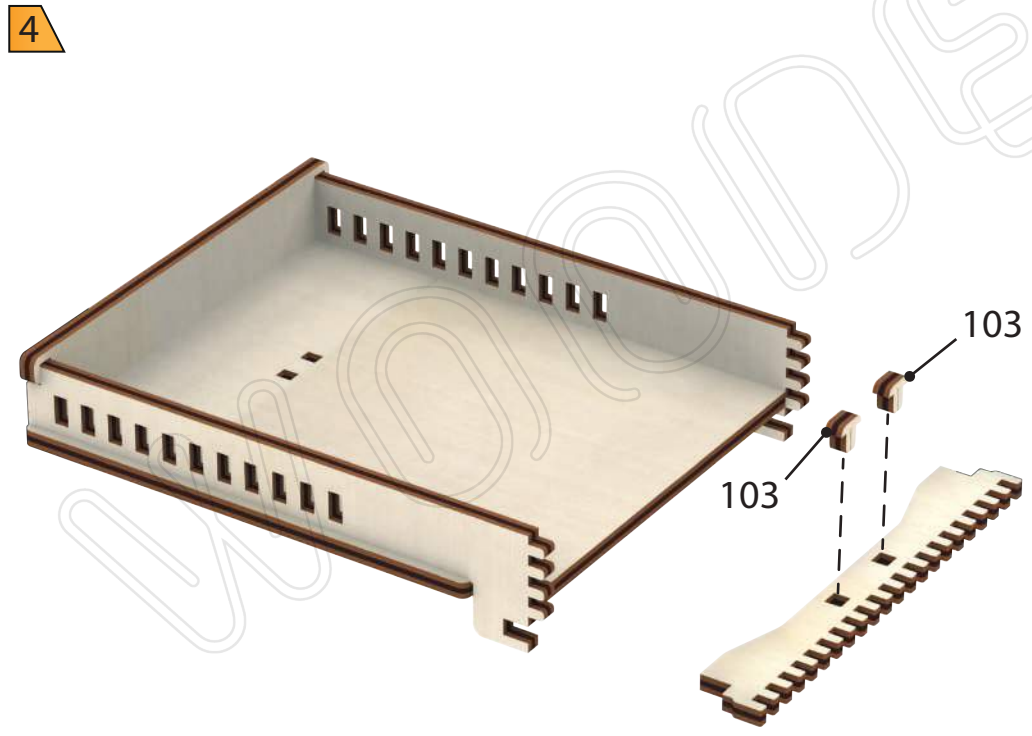

5

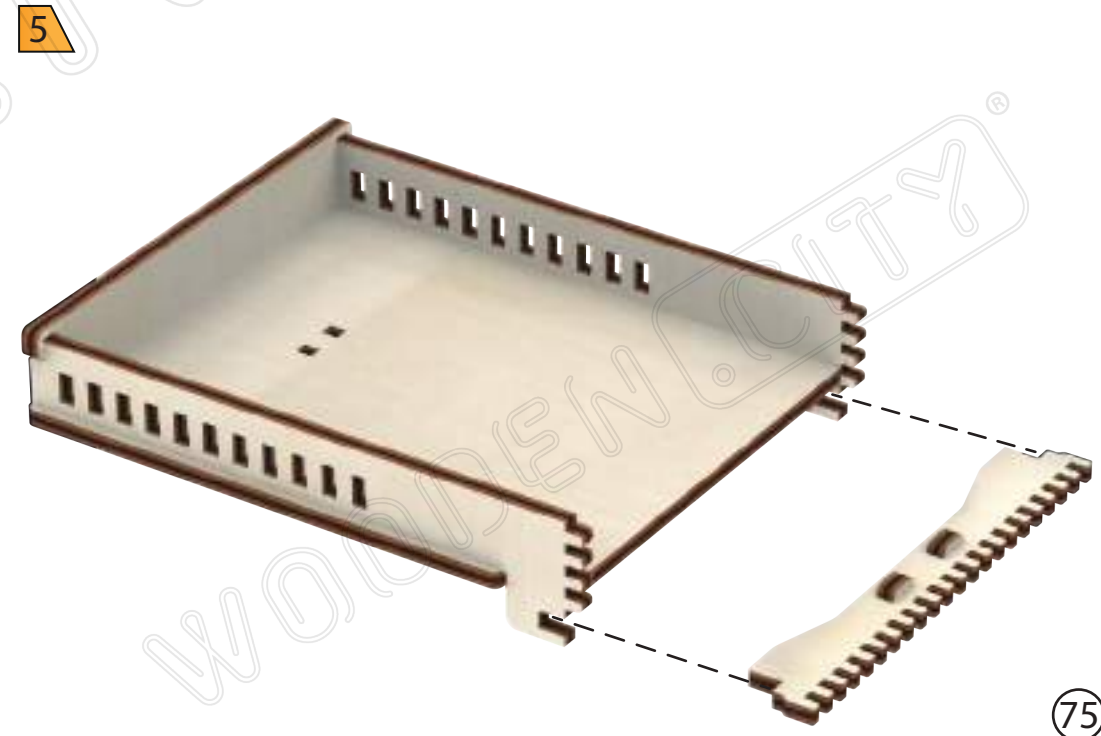

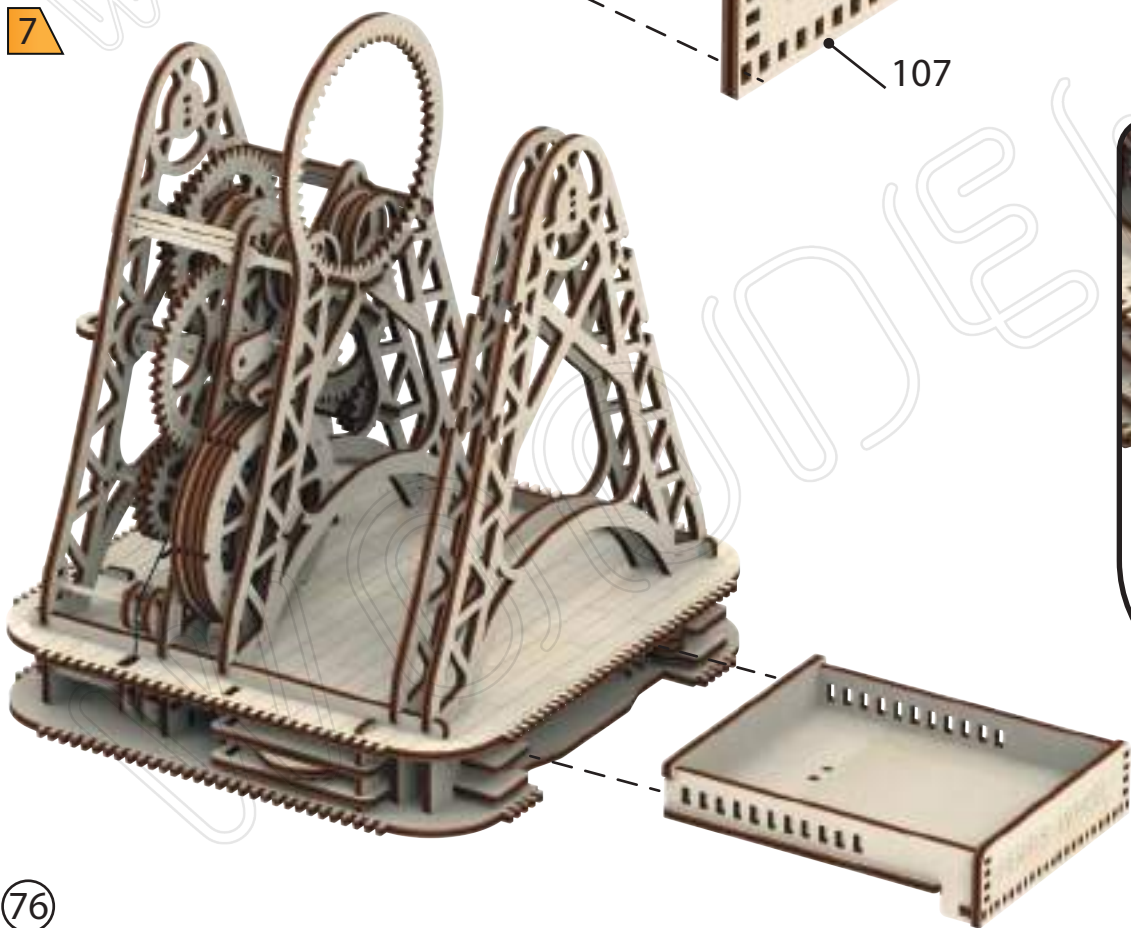
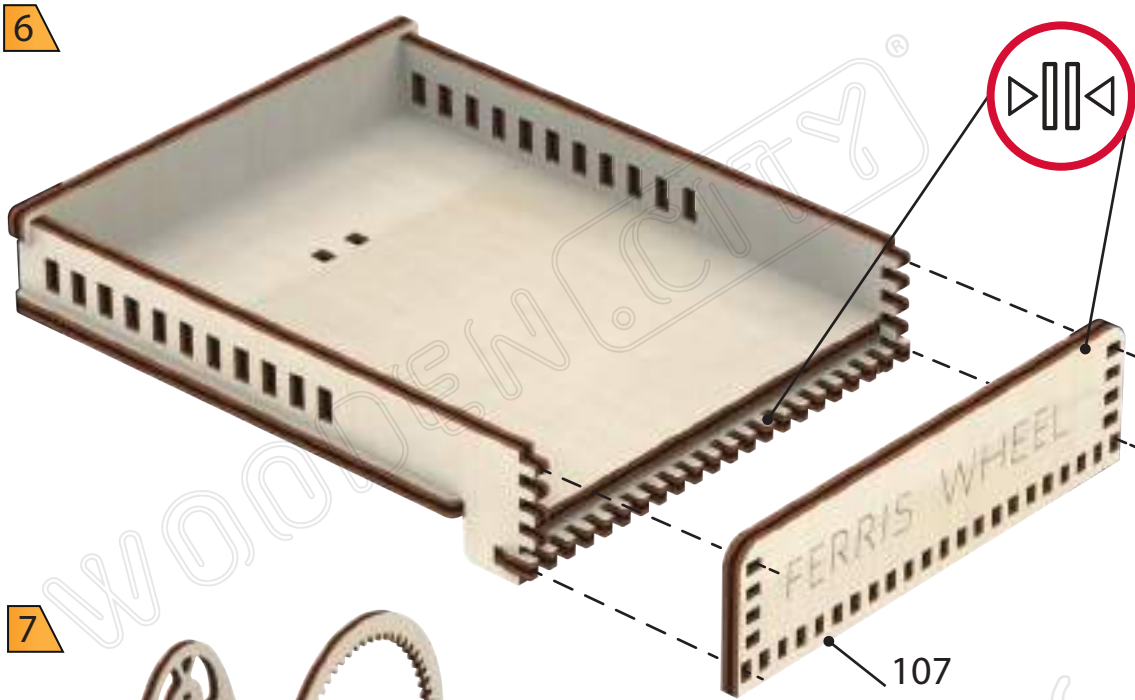

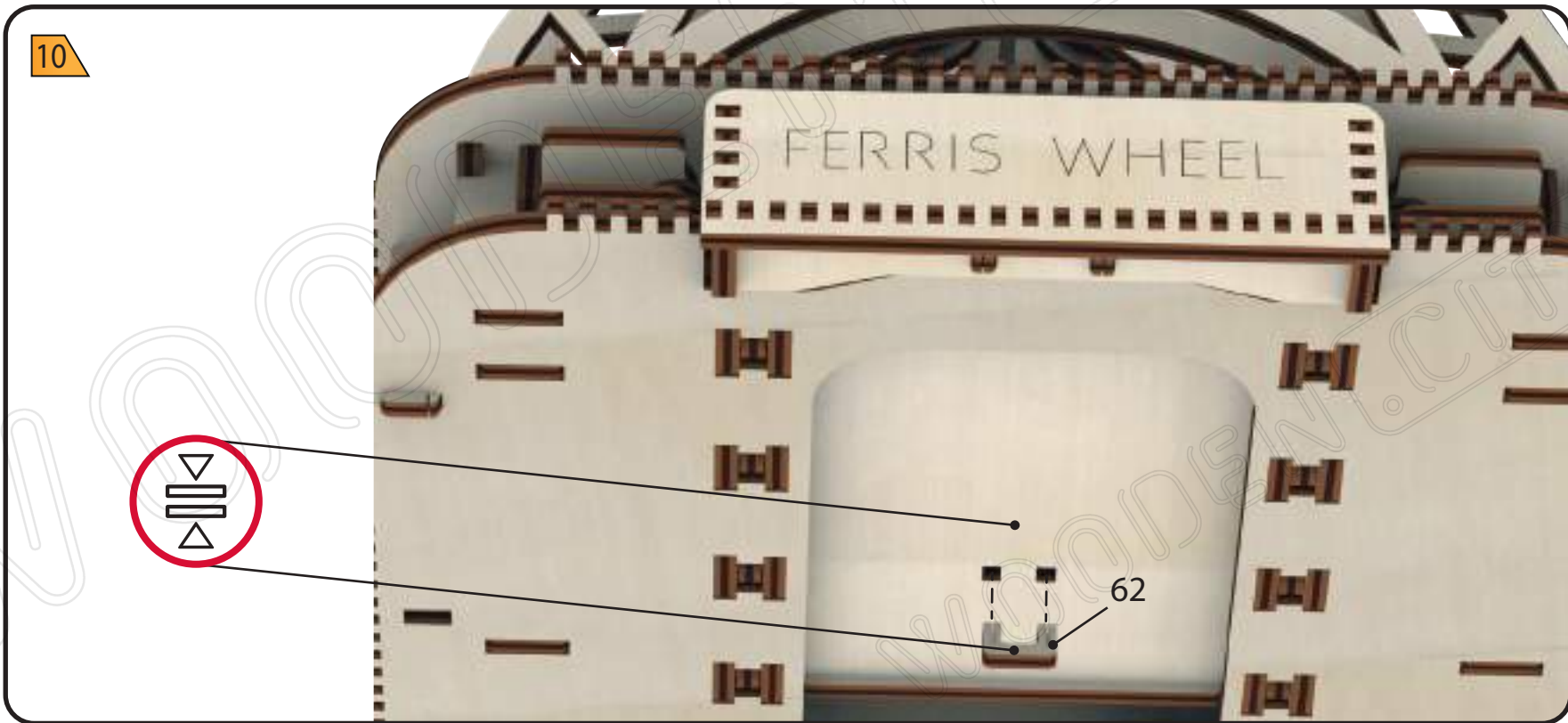

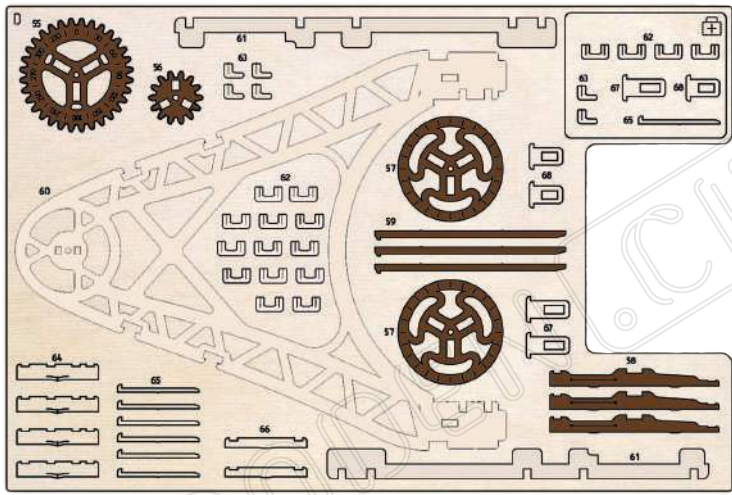

1

172 mm



56

2



57

57



(1:1)



172 mm

3

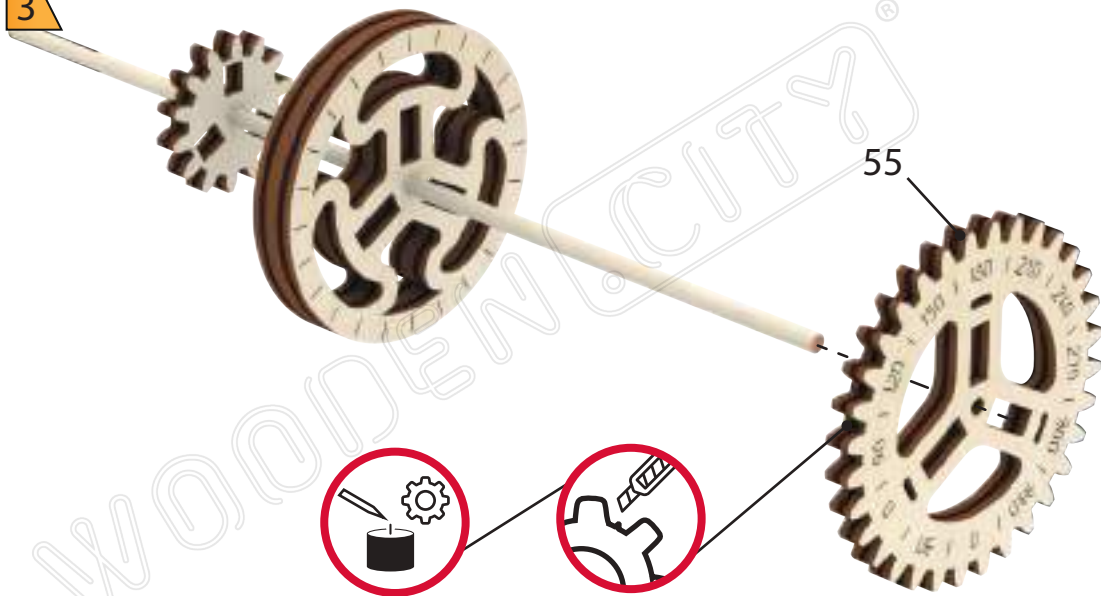

4



5



58

6

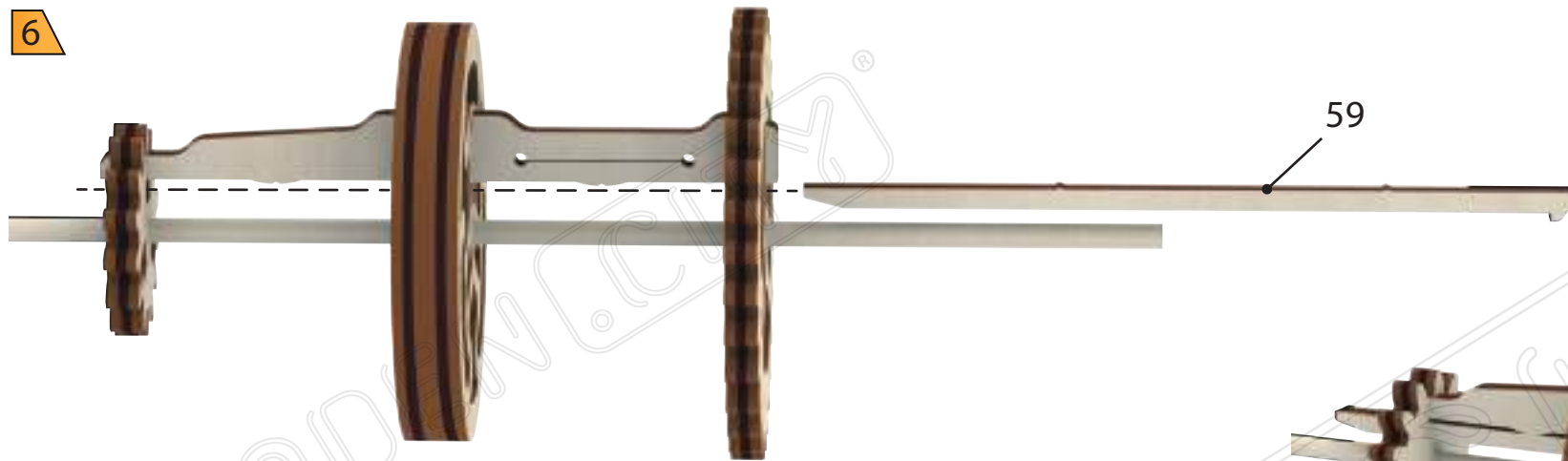

7



8

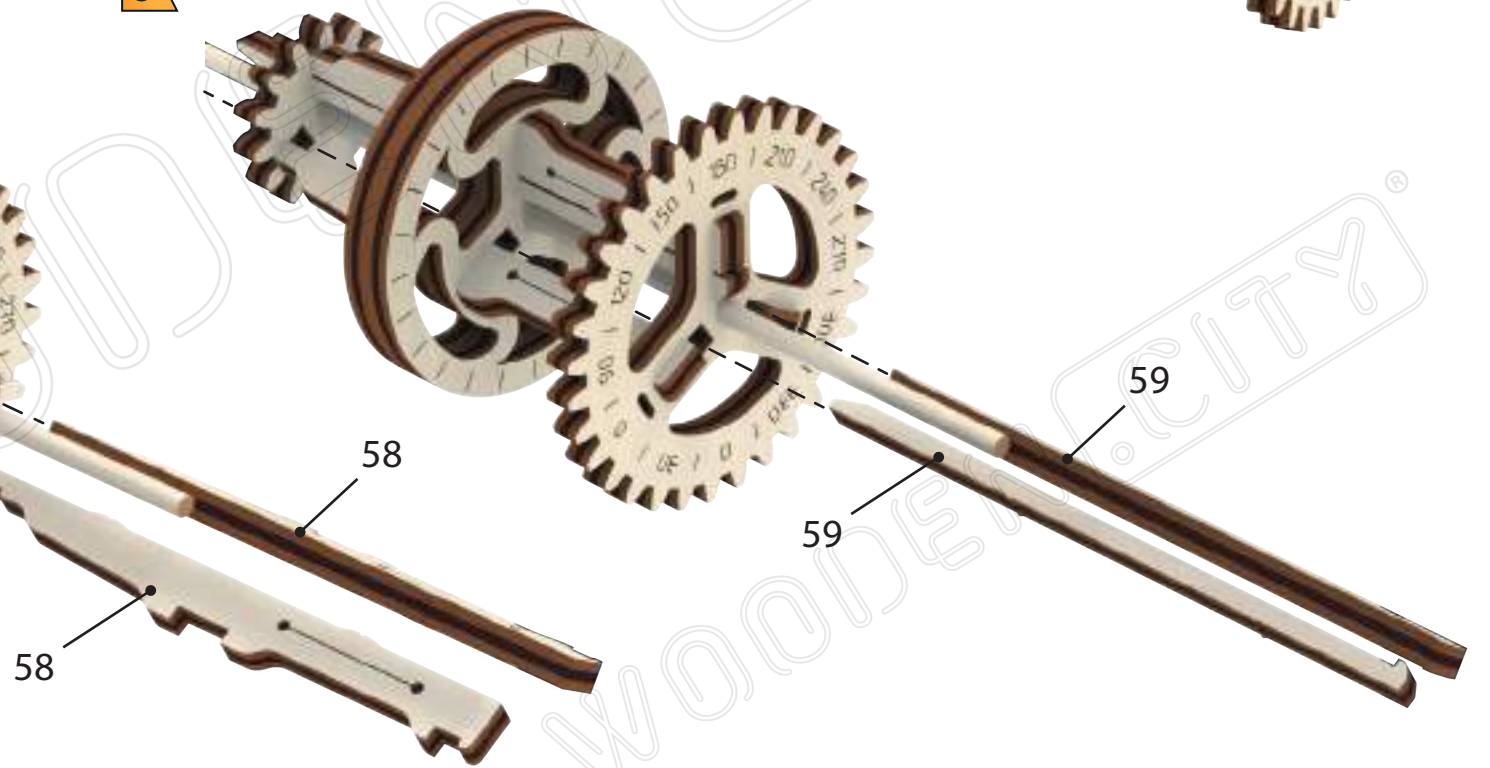

80

®

®

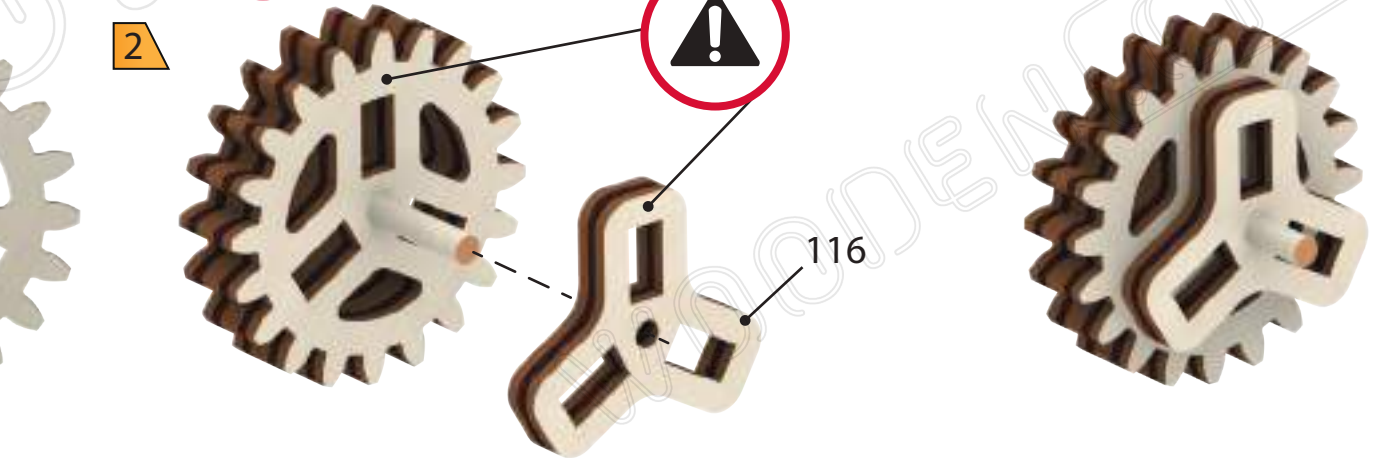
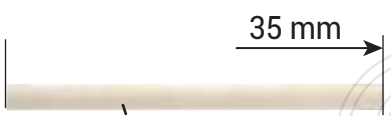
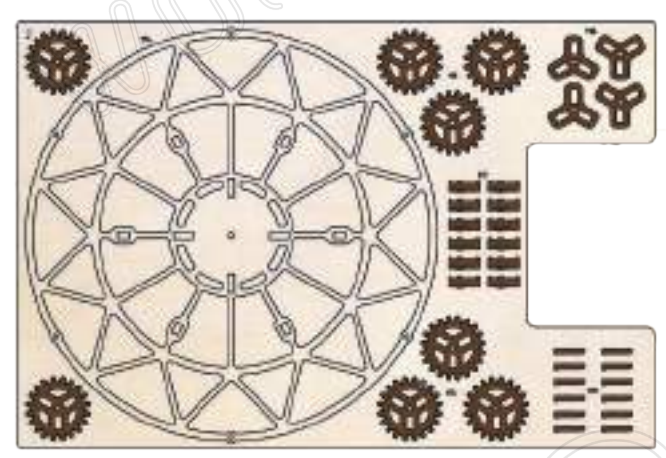

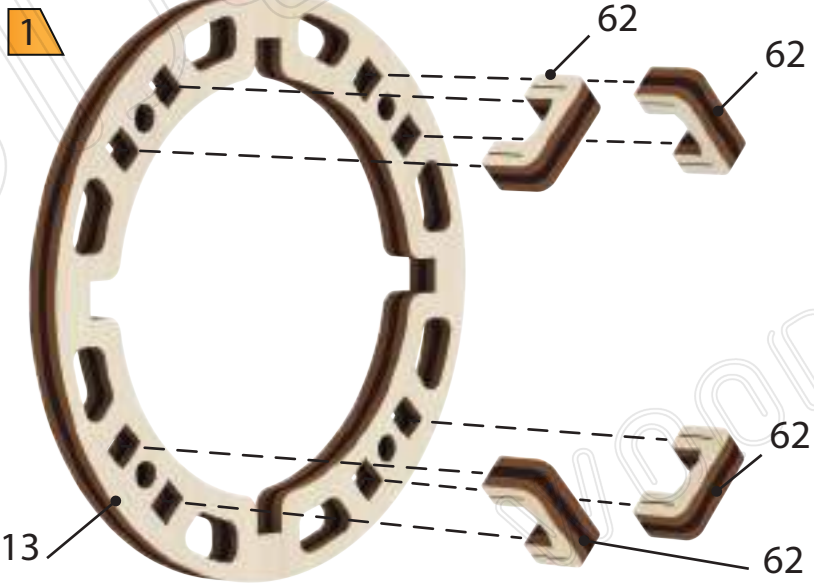
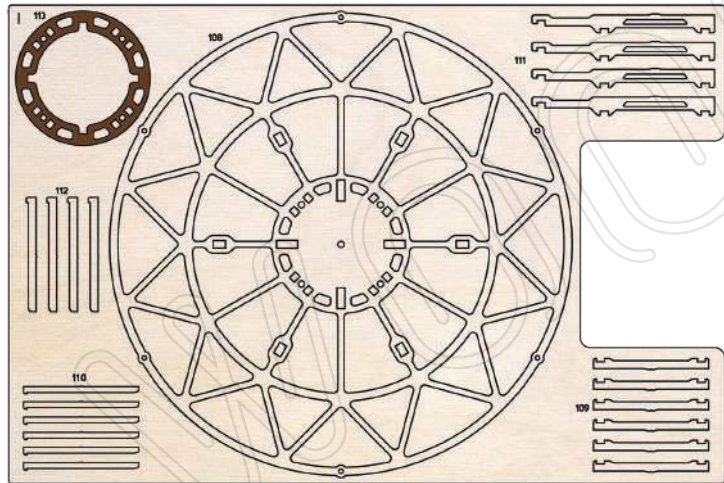
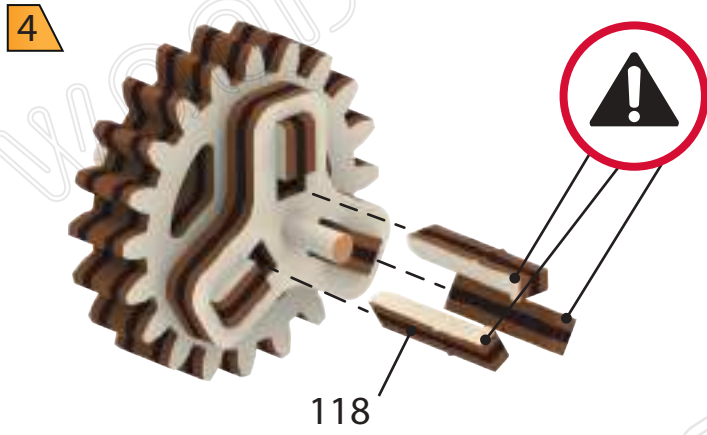
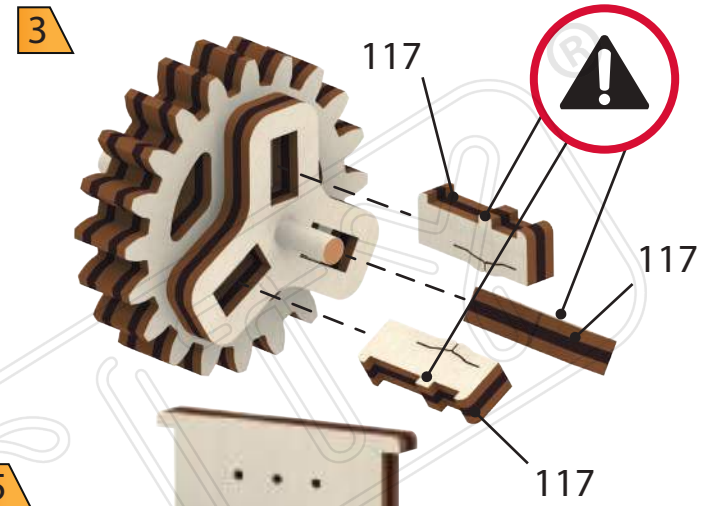
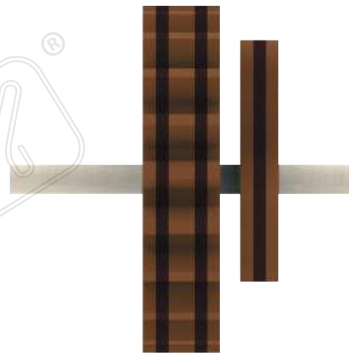

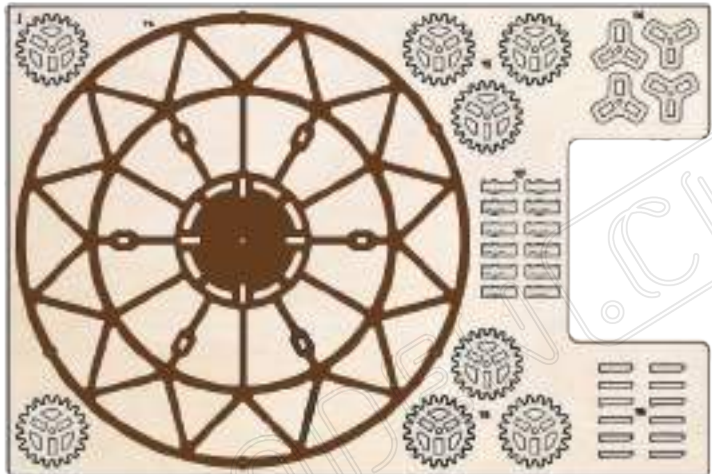

4

114

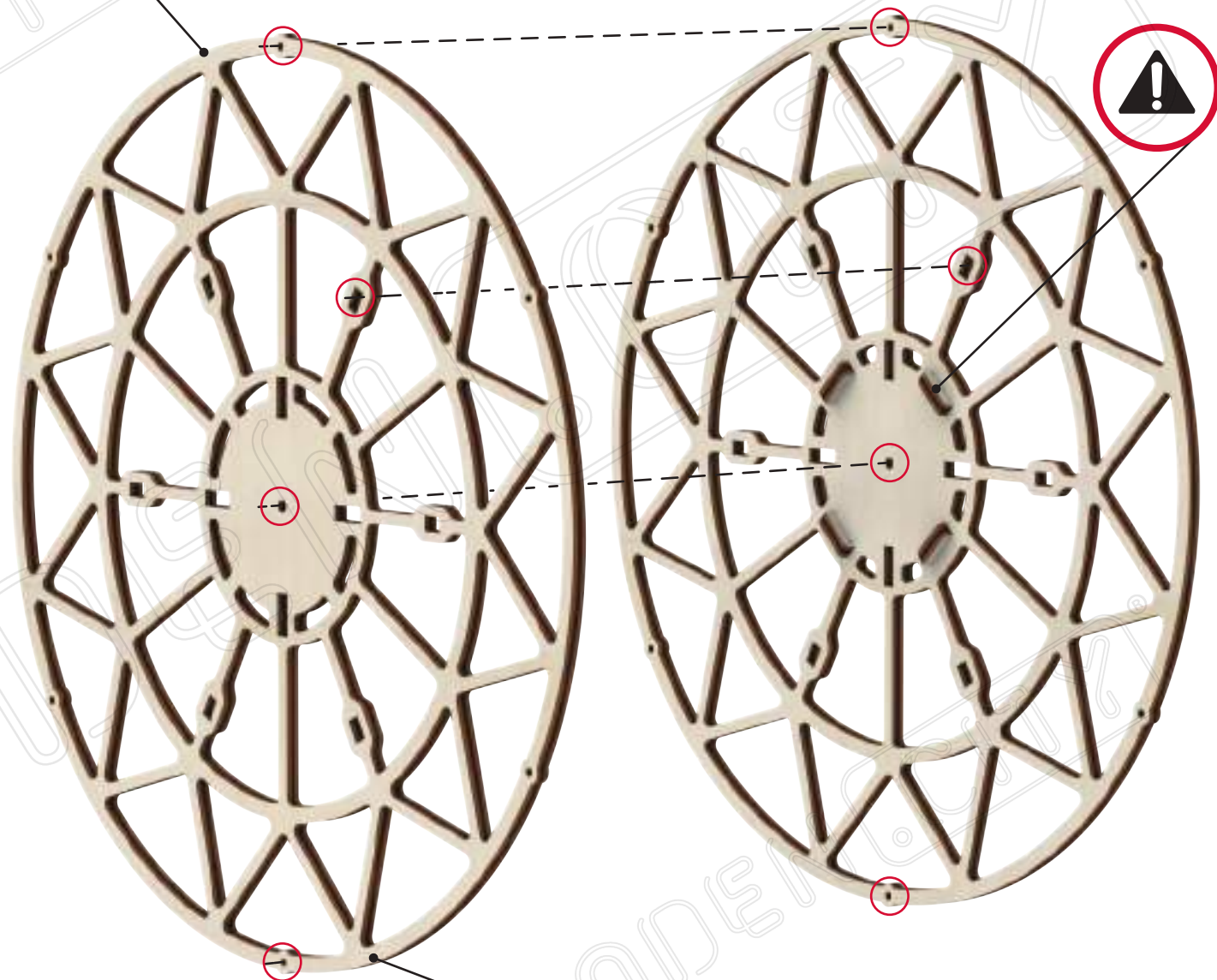

5

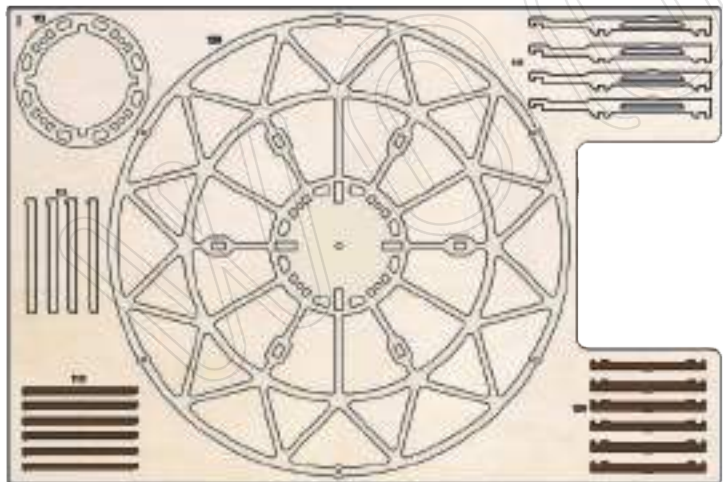
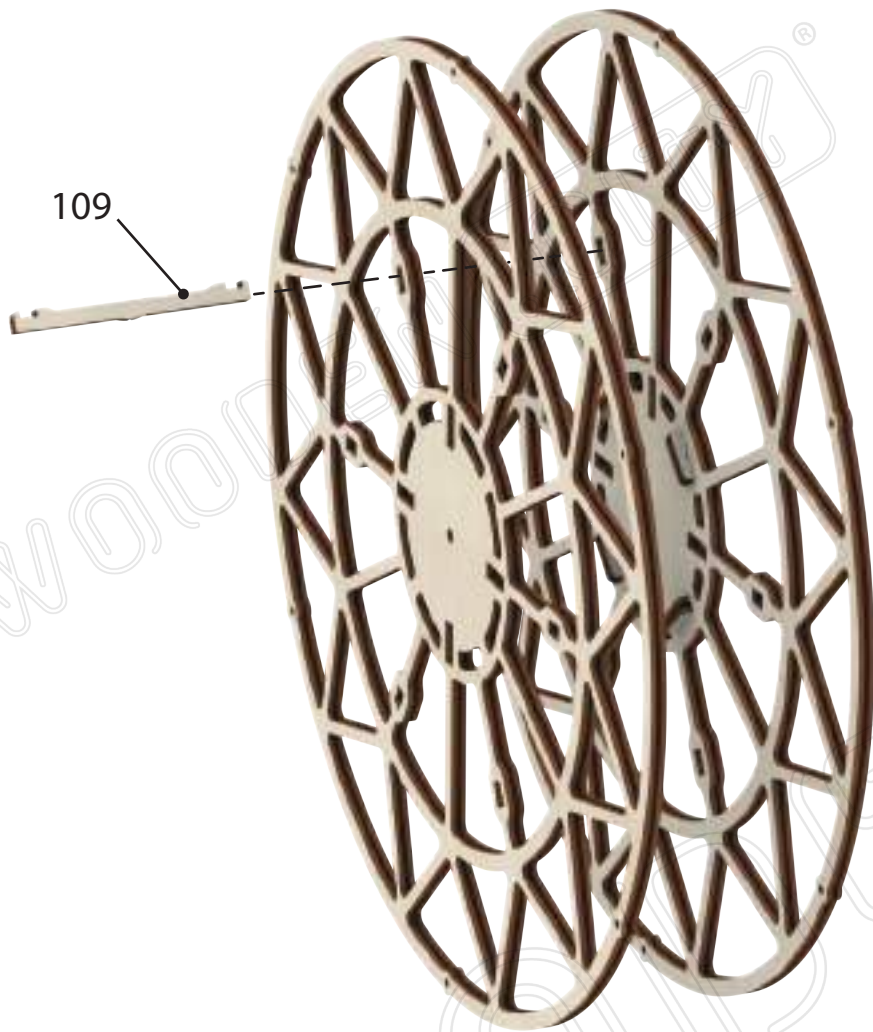

6

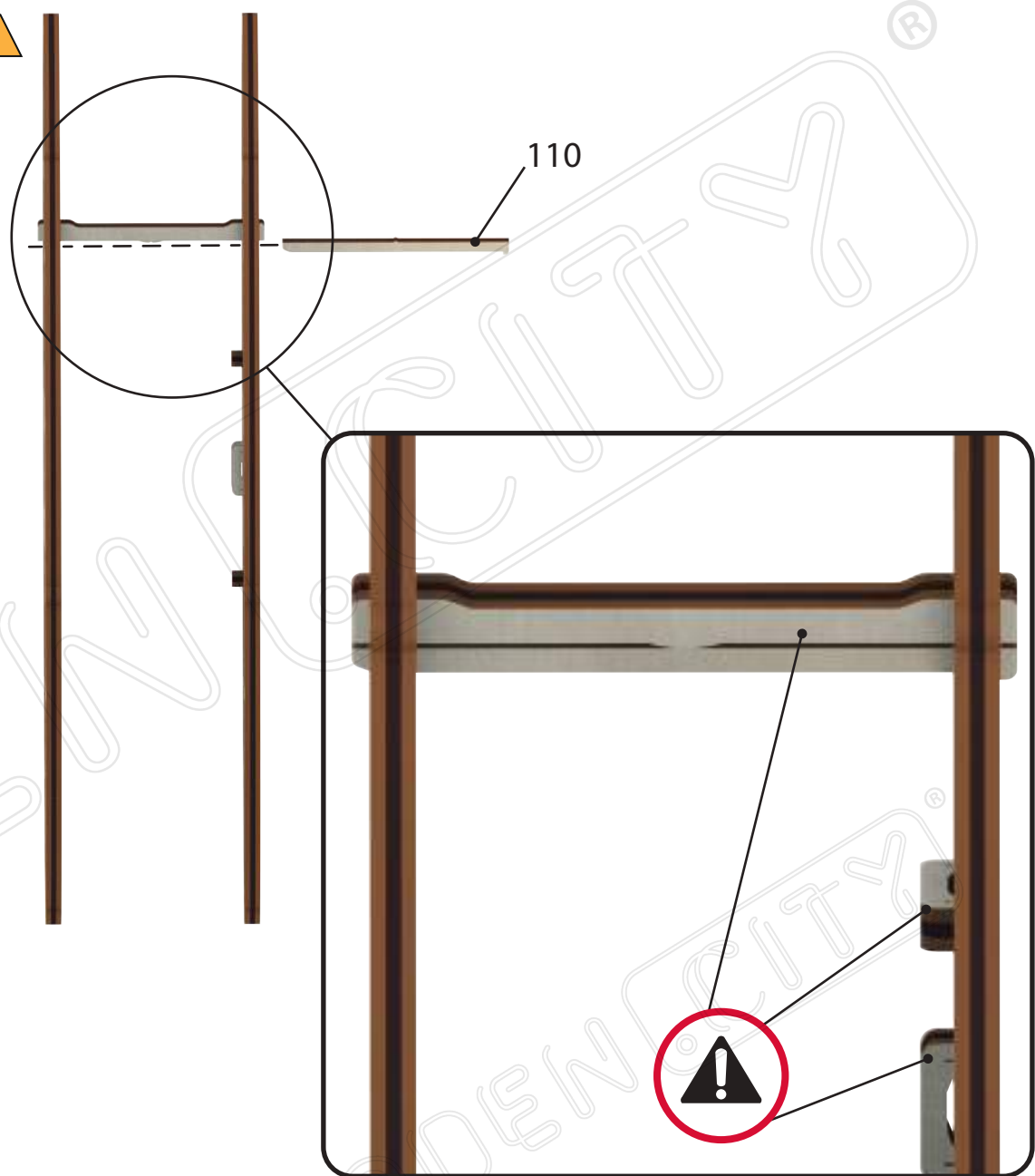

7

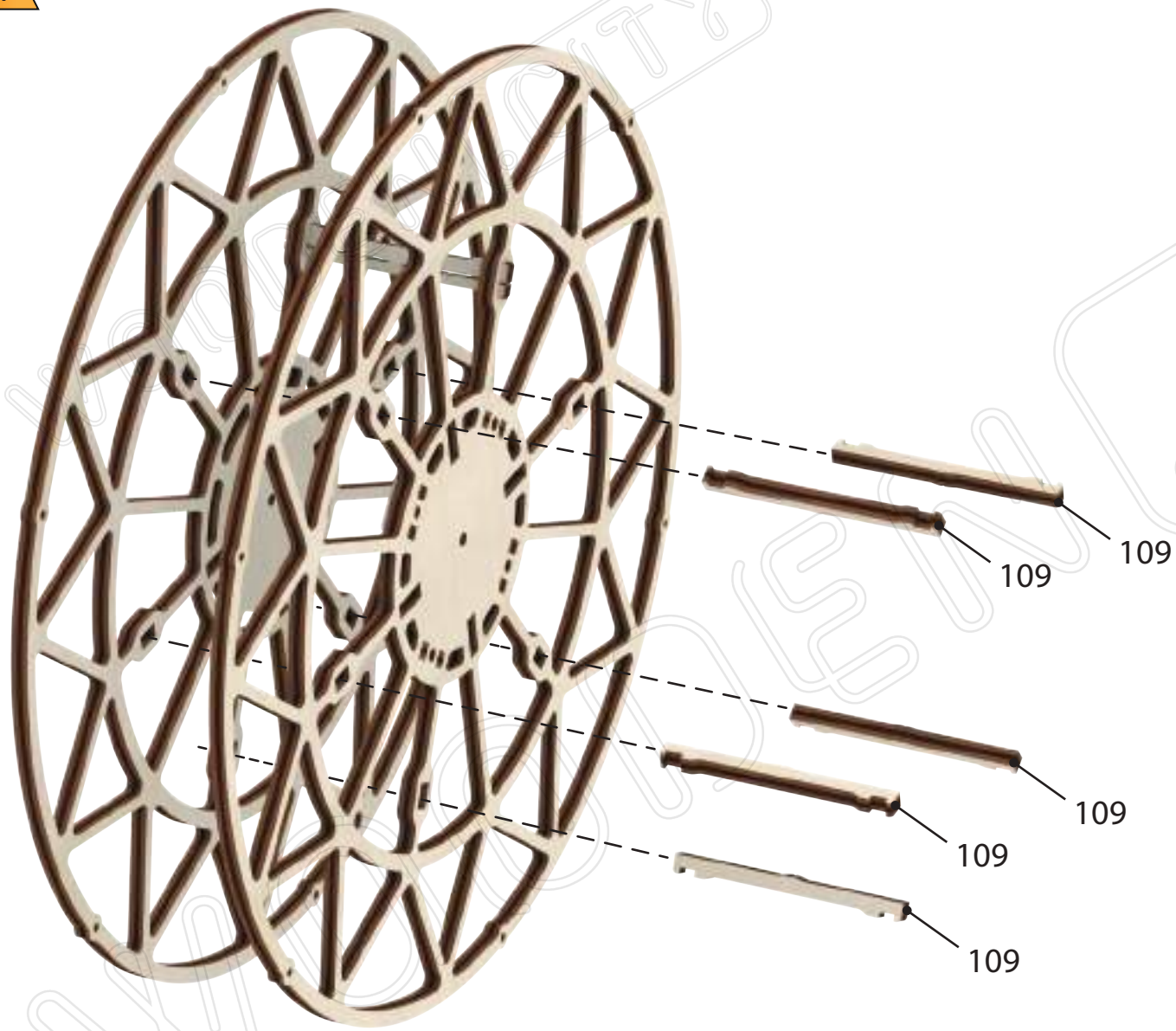

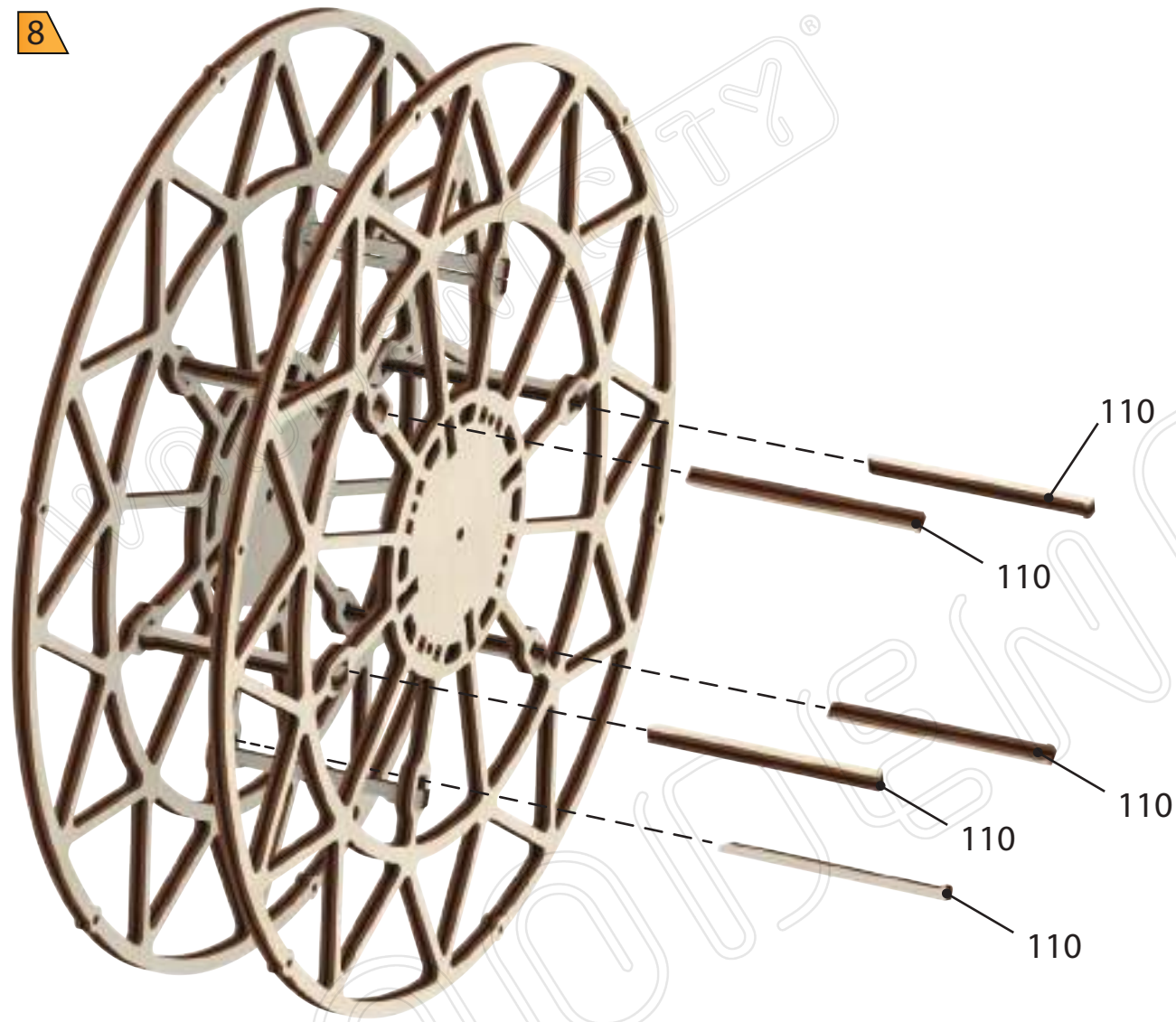

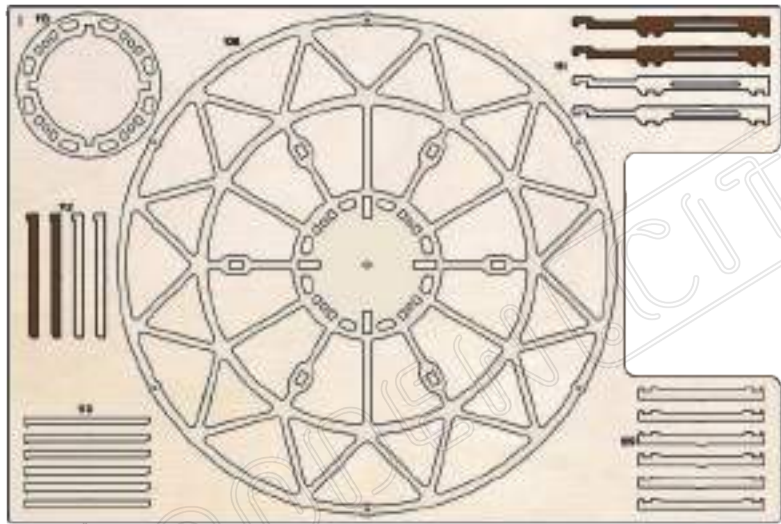

9

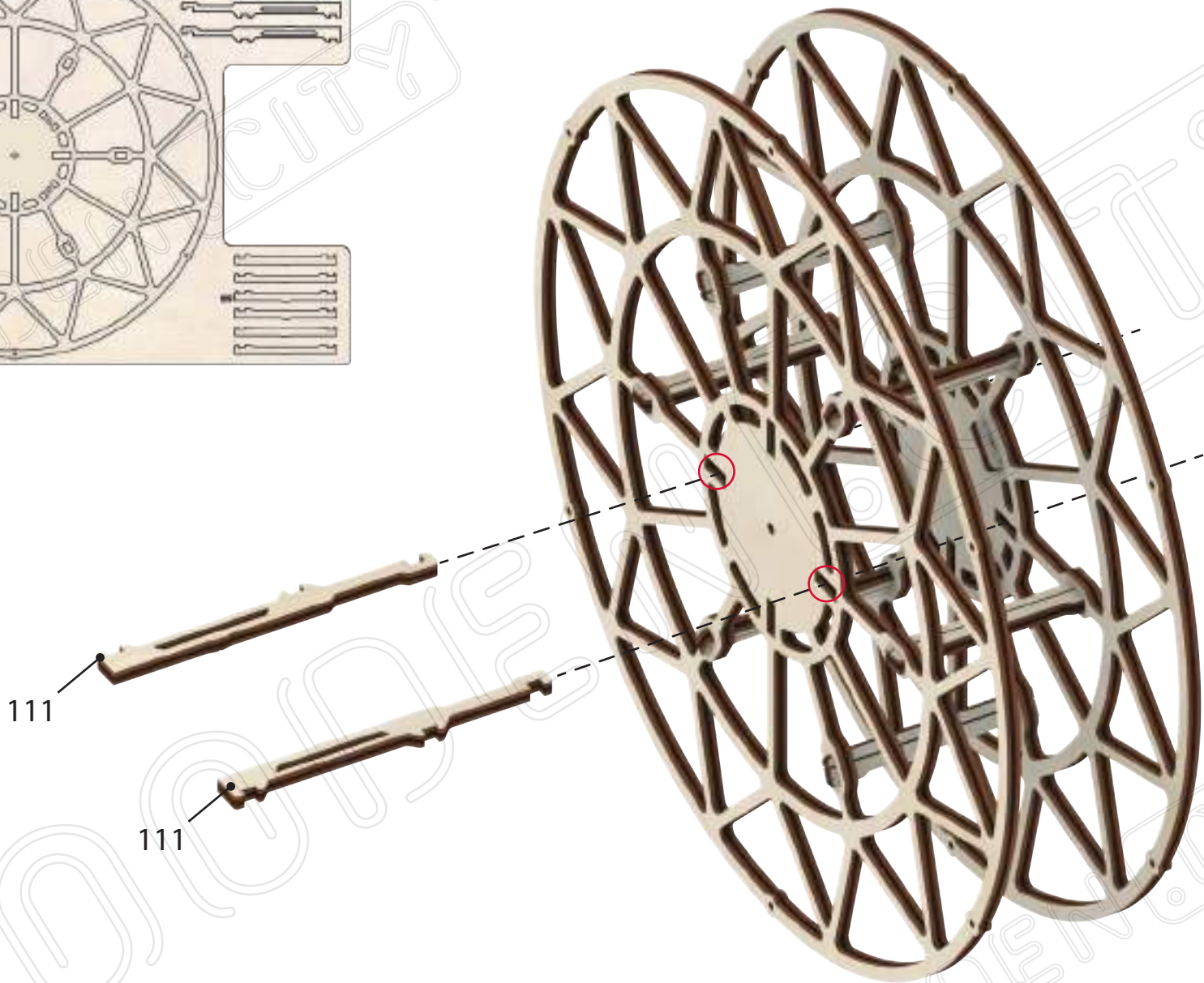

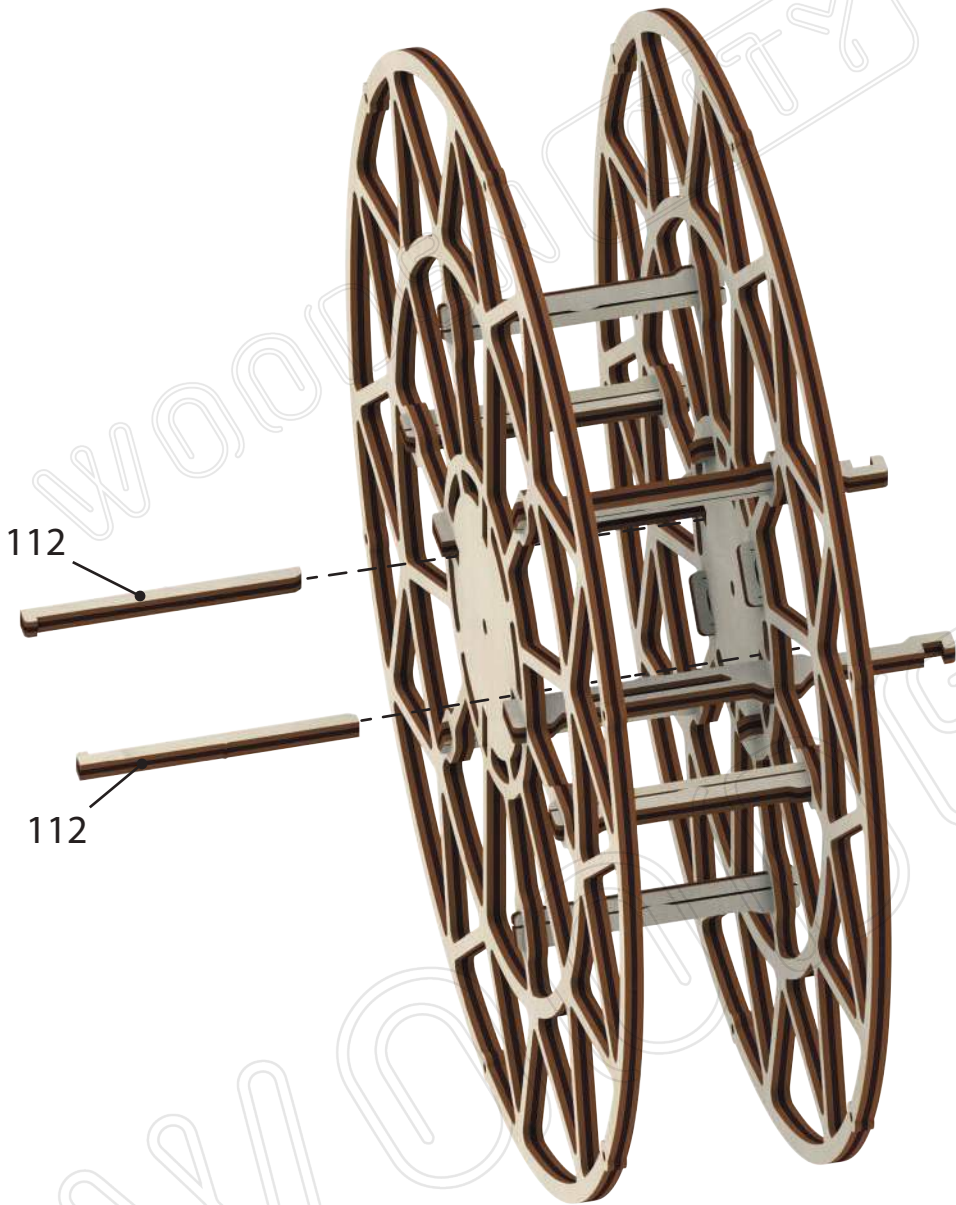

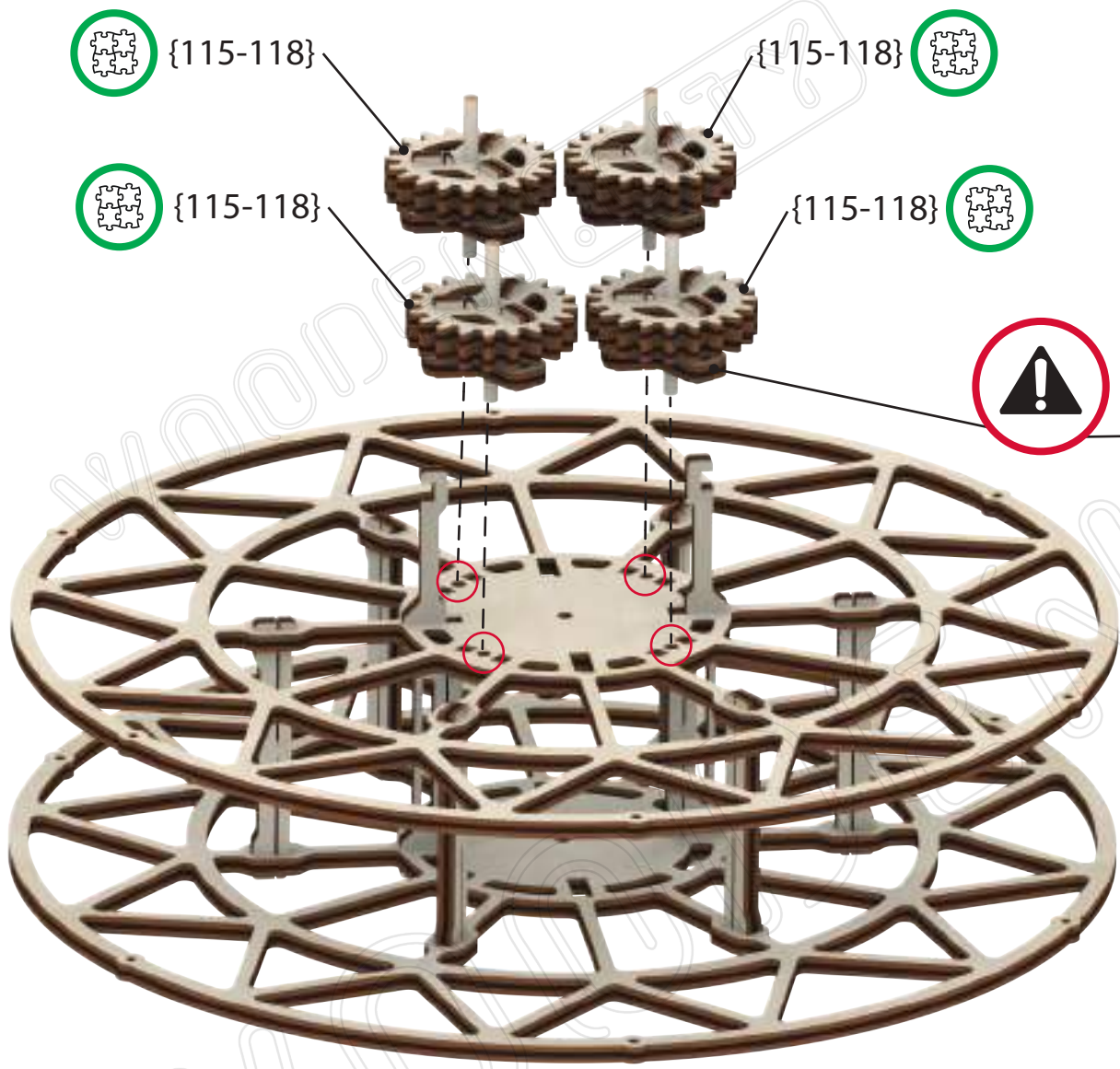

12

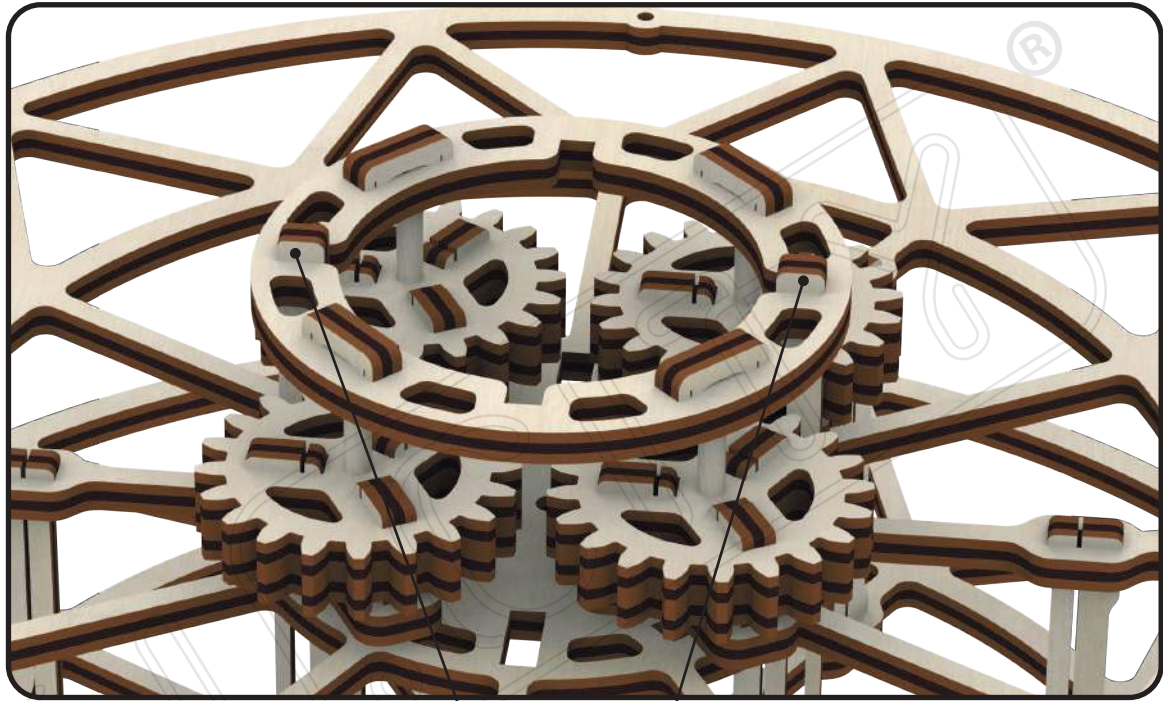
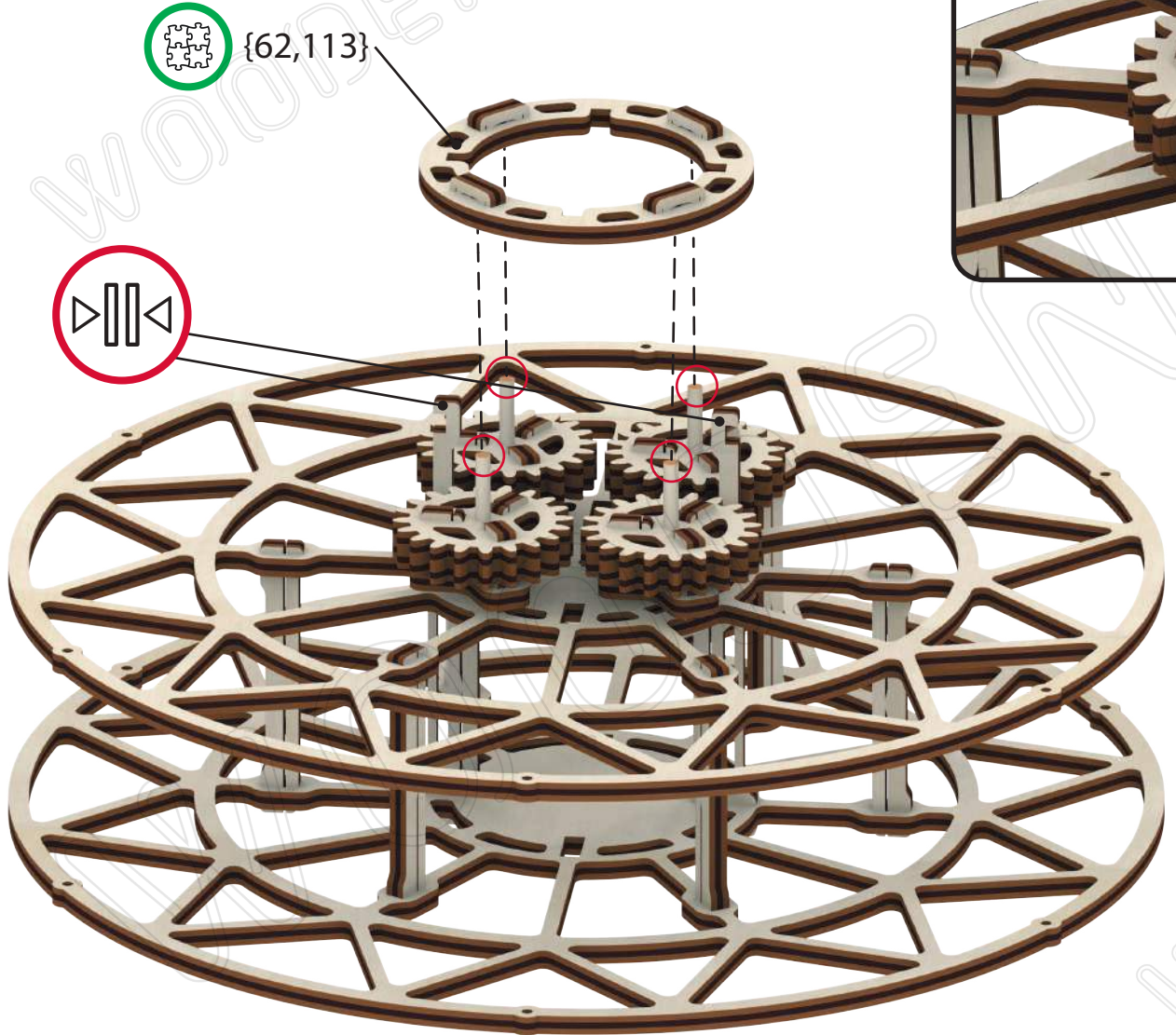

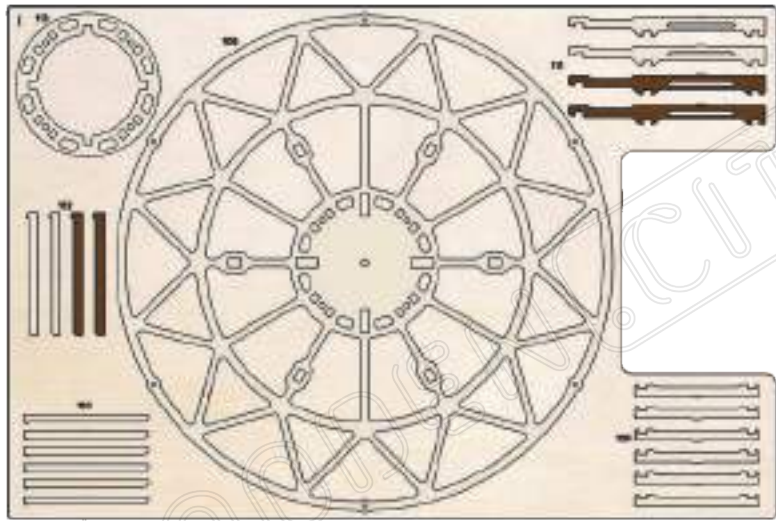

13

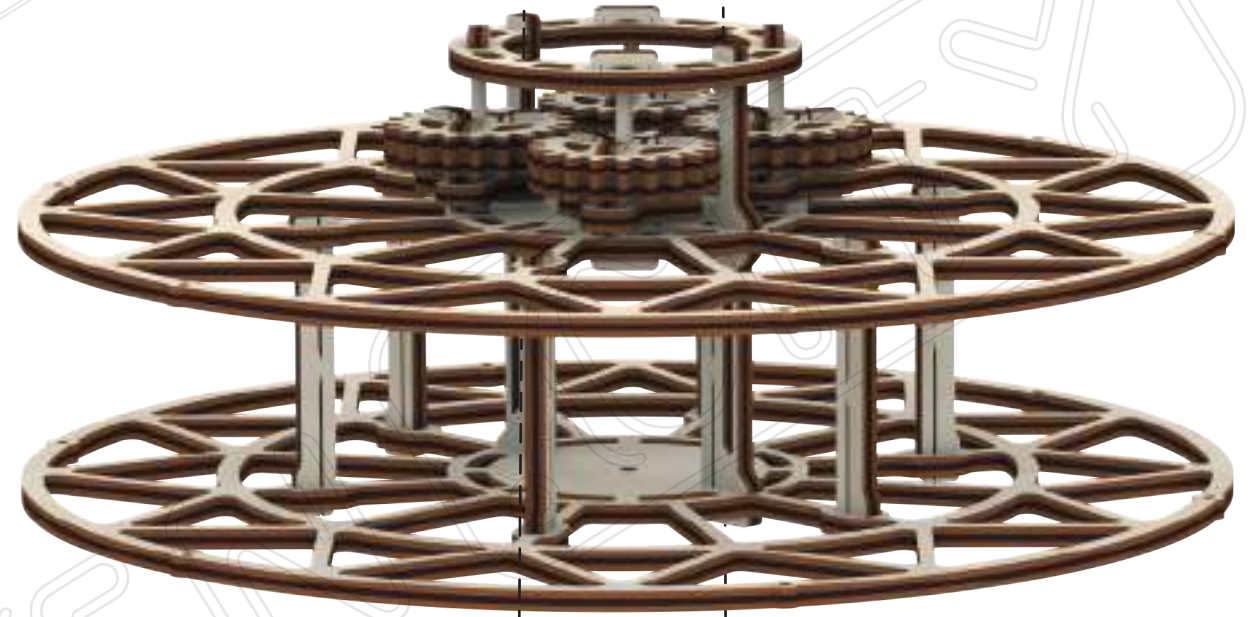

111

111

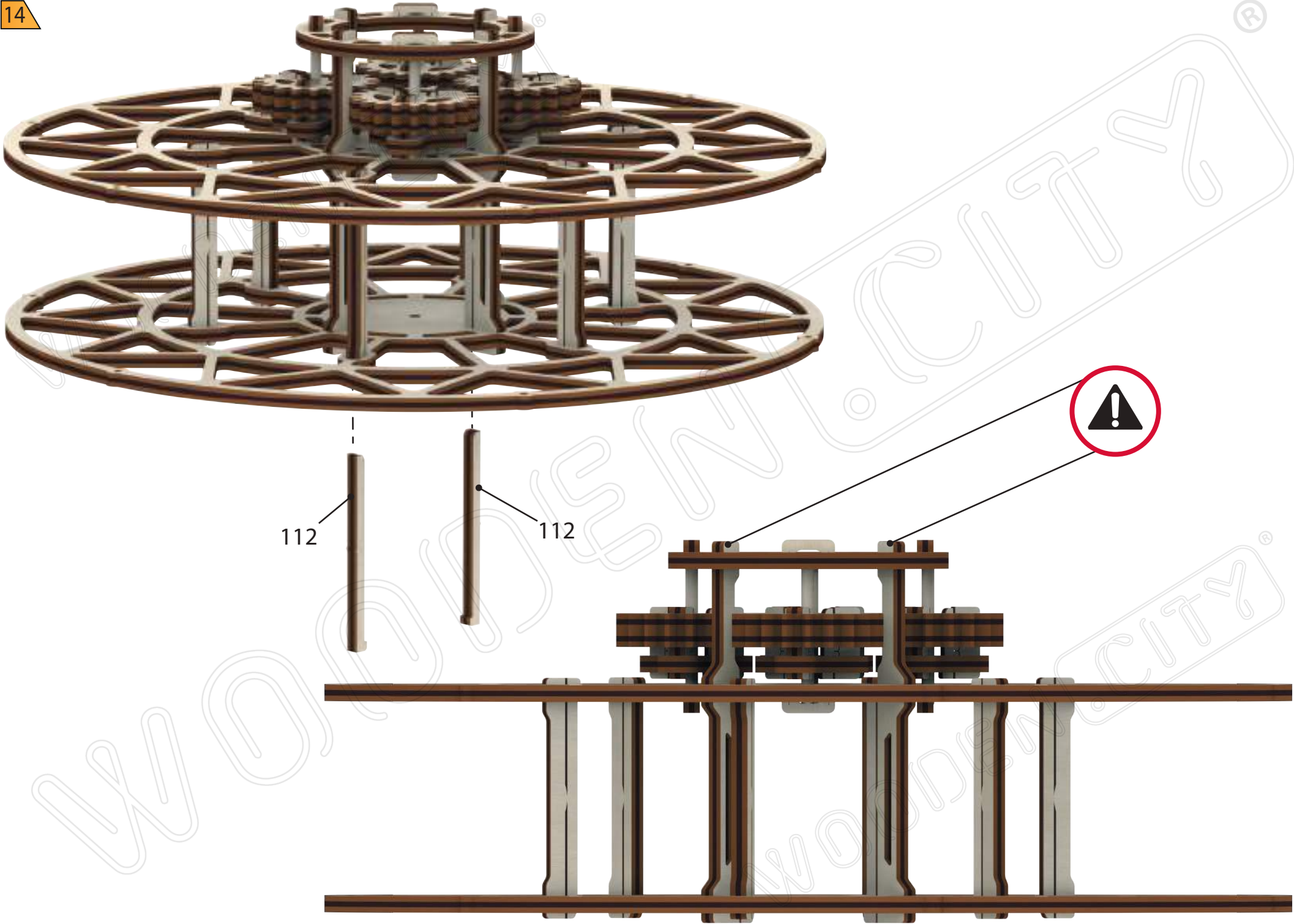

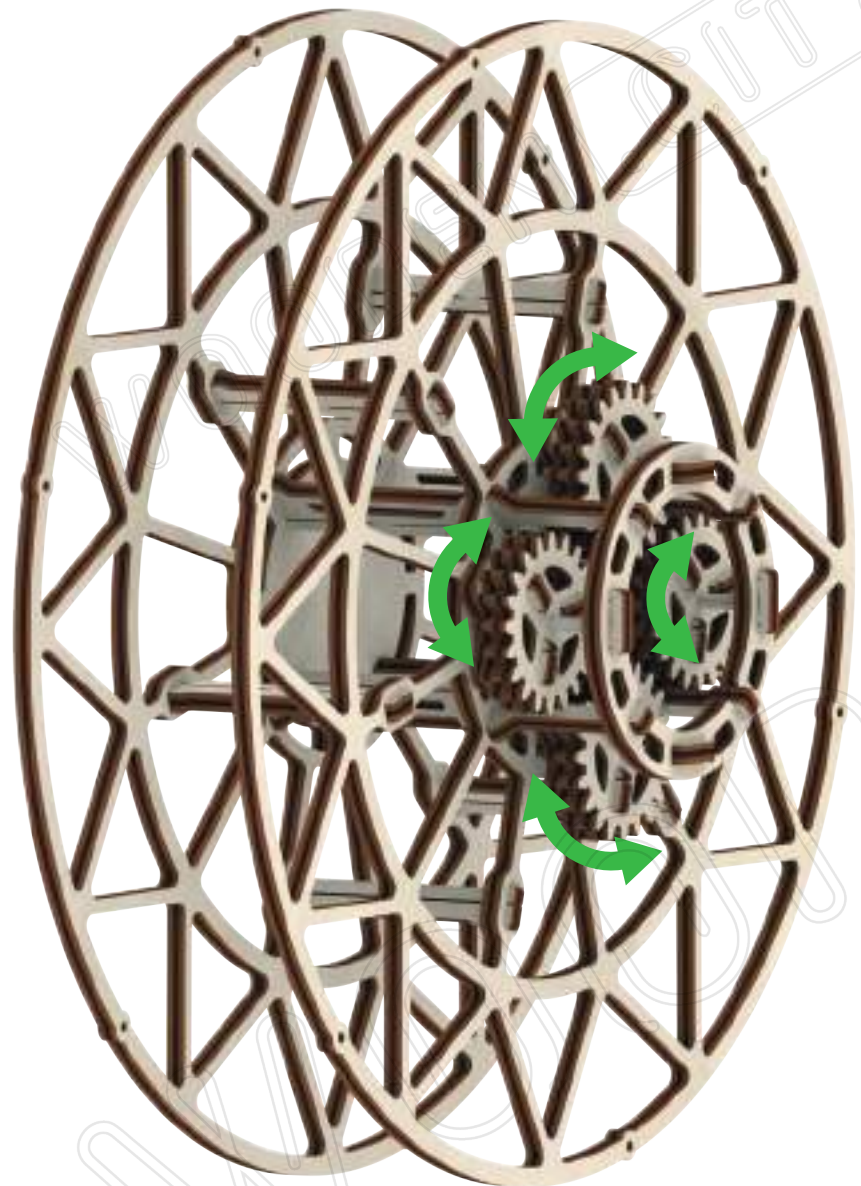

x2



x2



x2

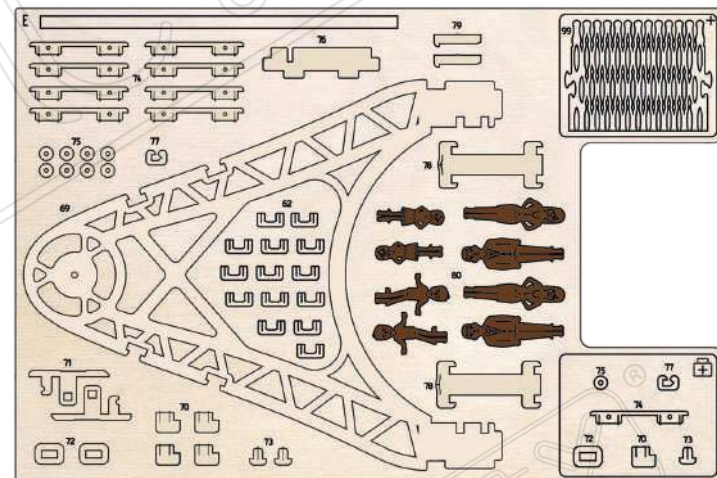
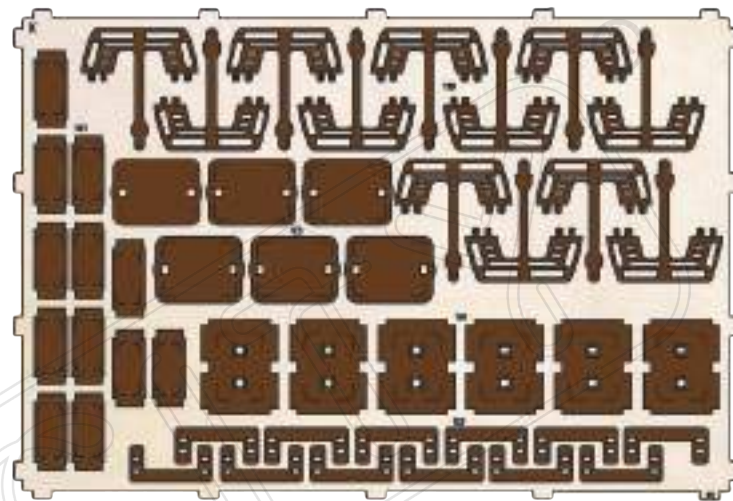

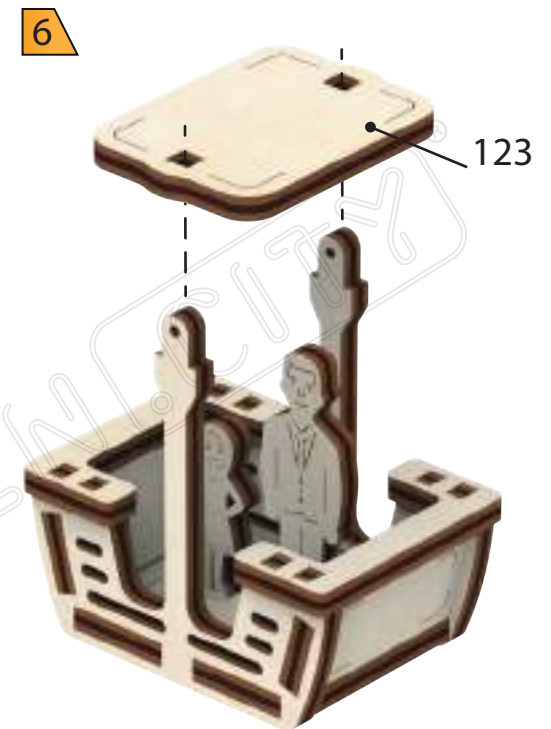
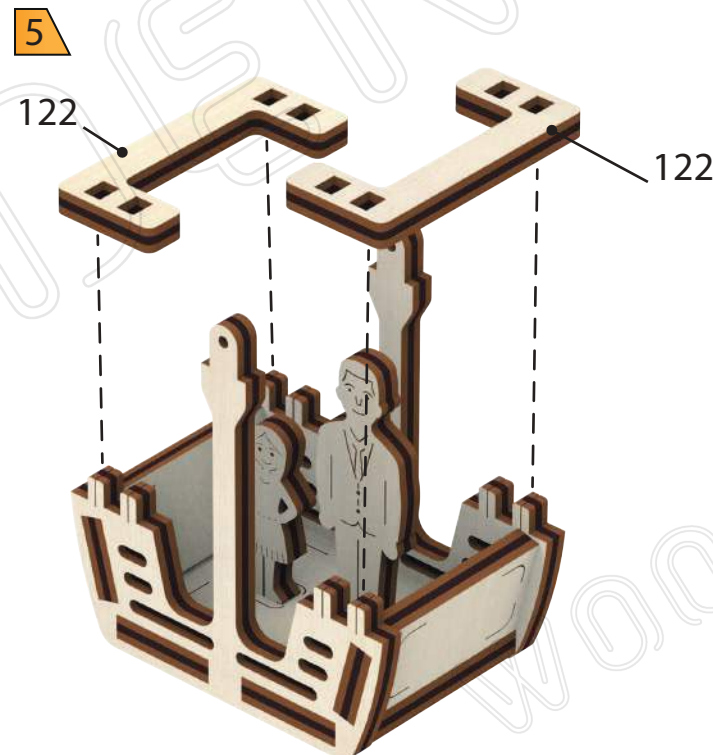
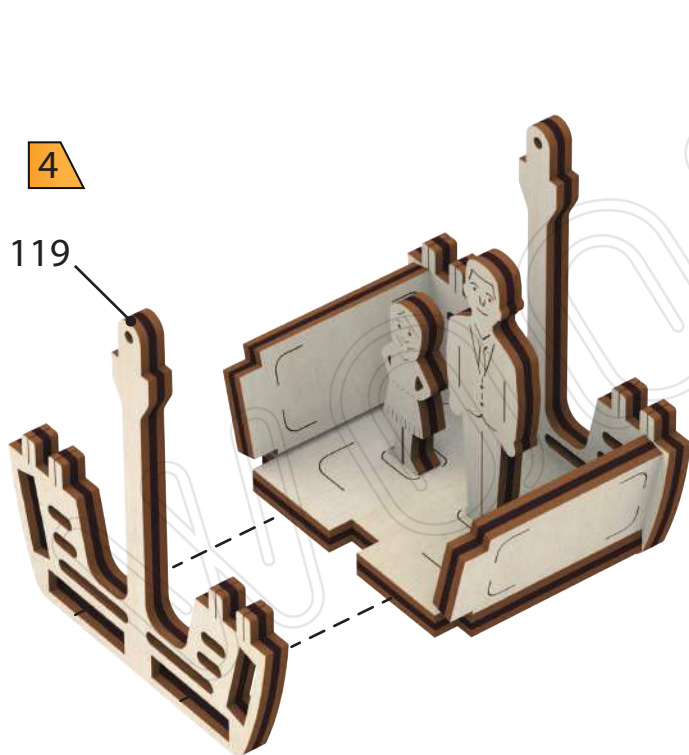
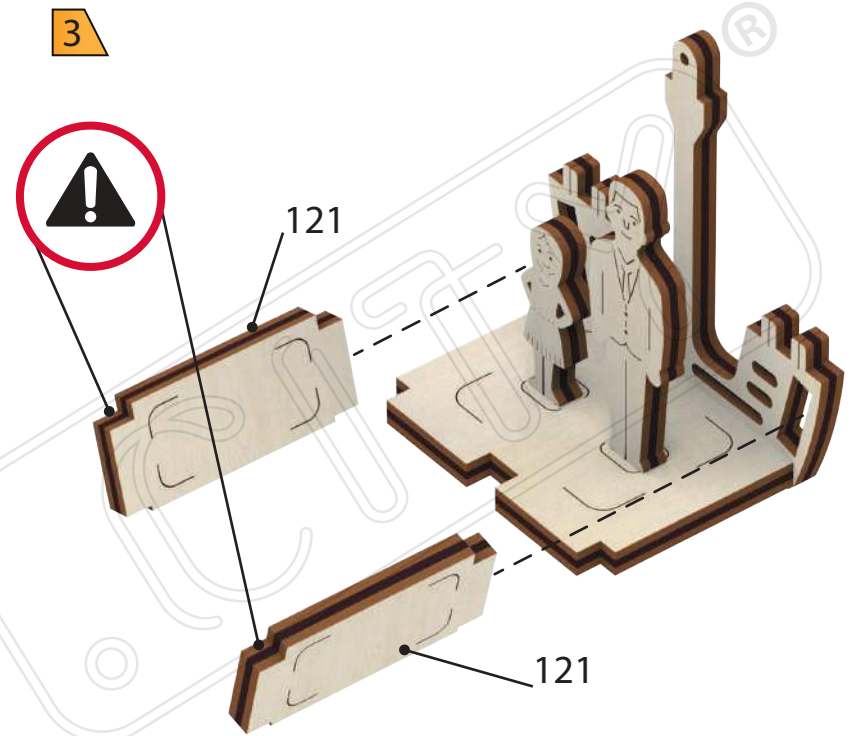
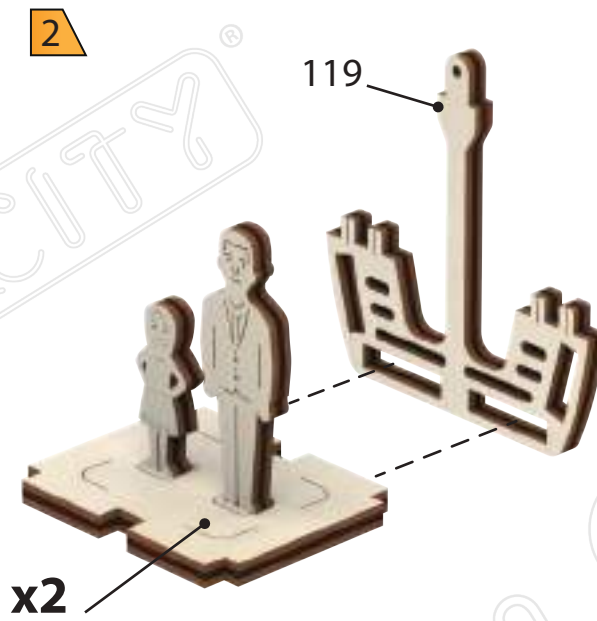
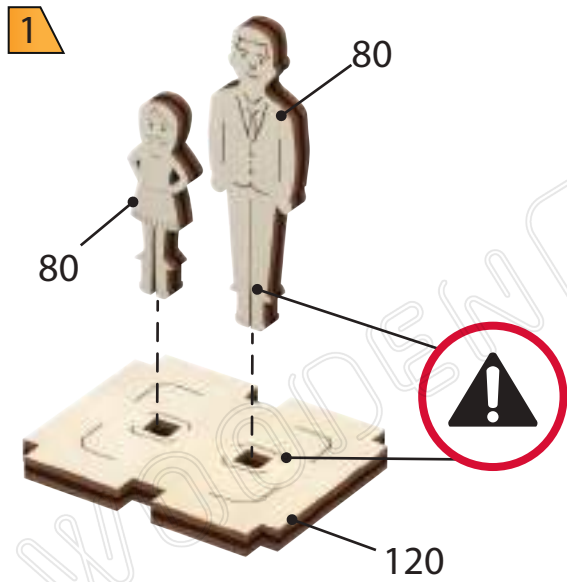

7

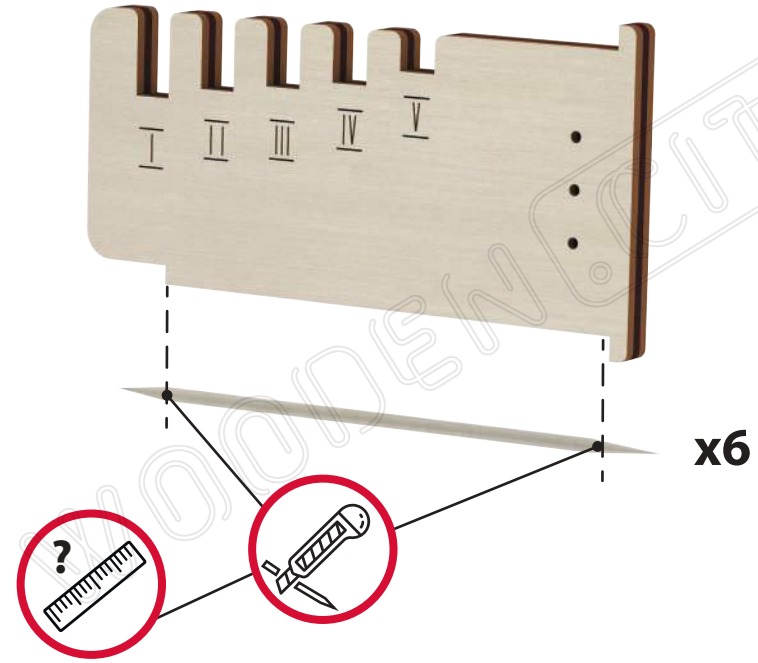

8

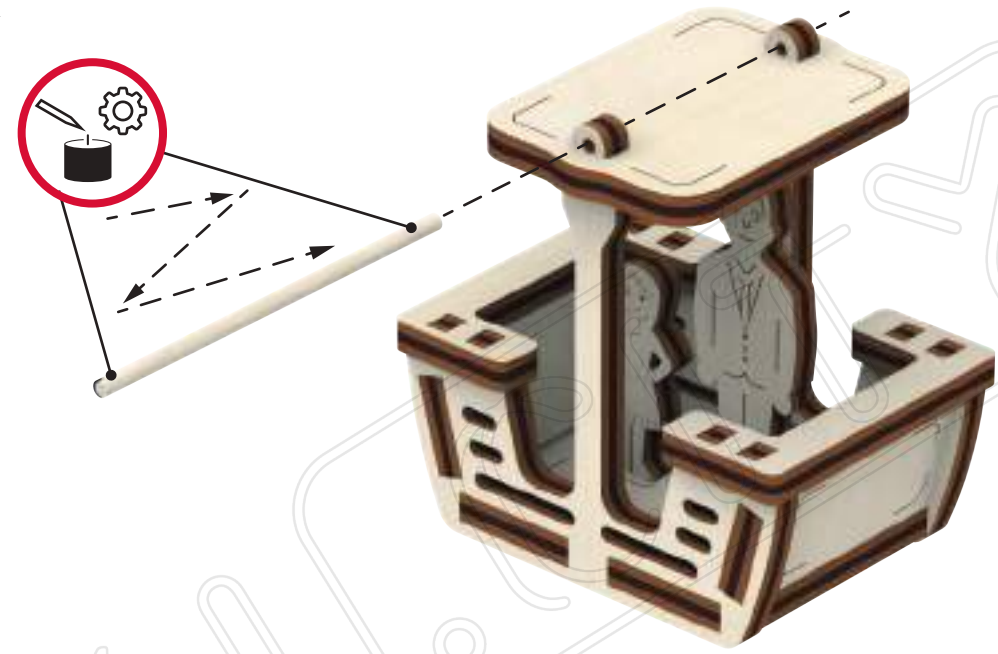

1

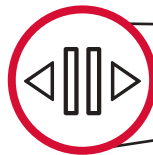
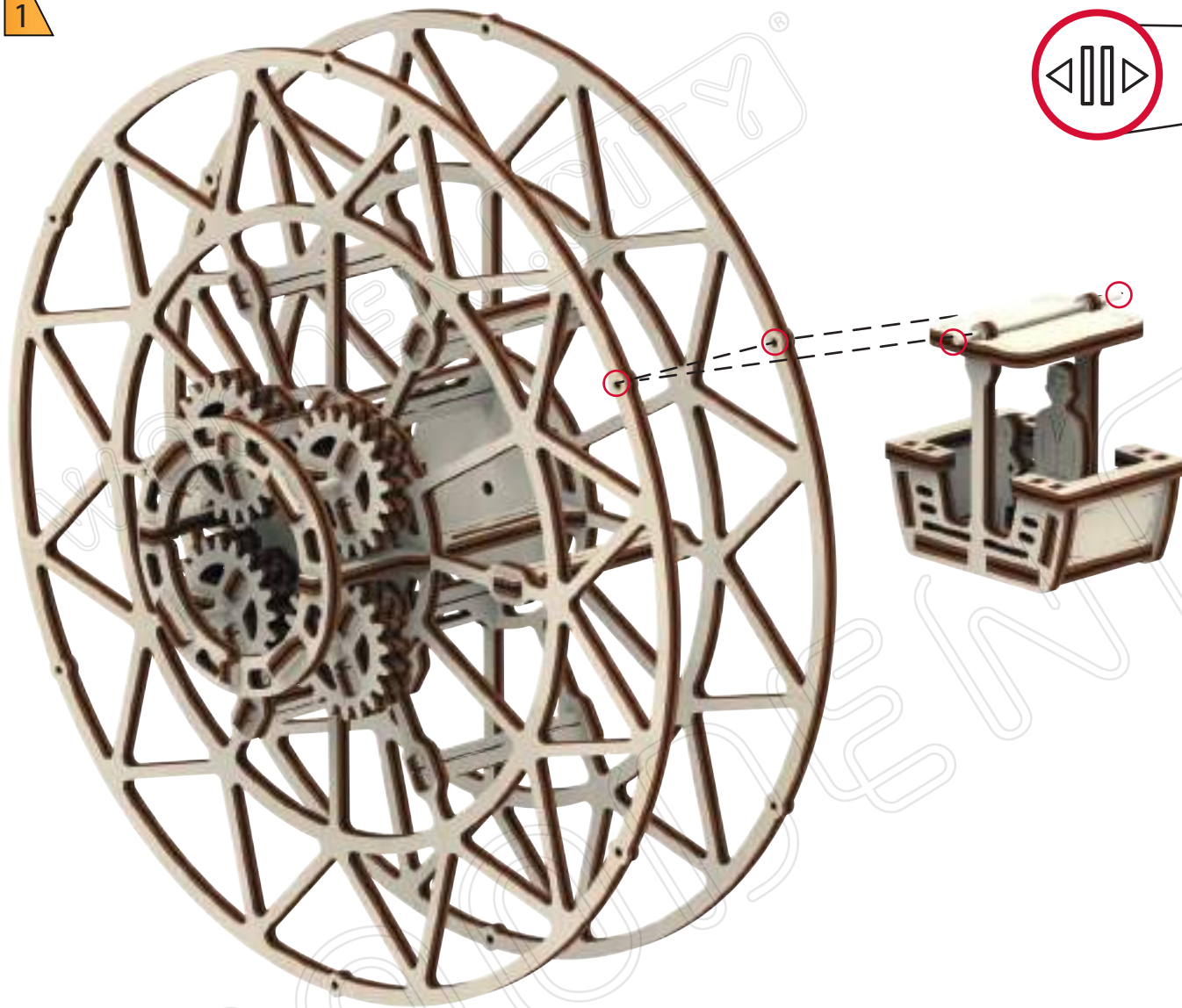

2

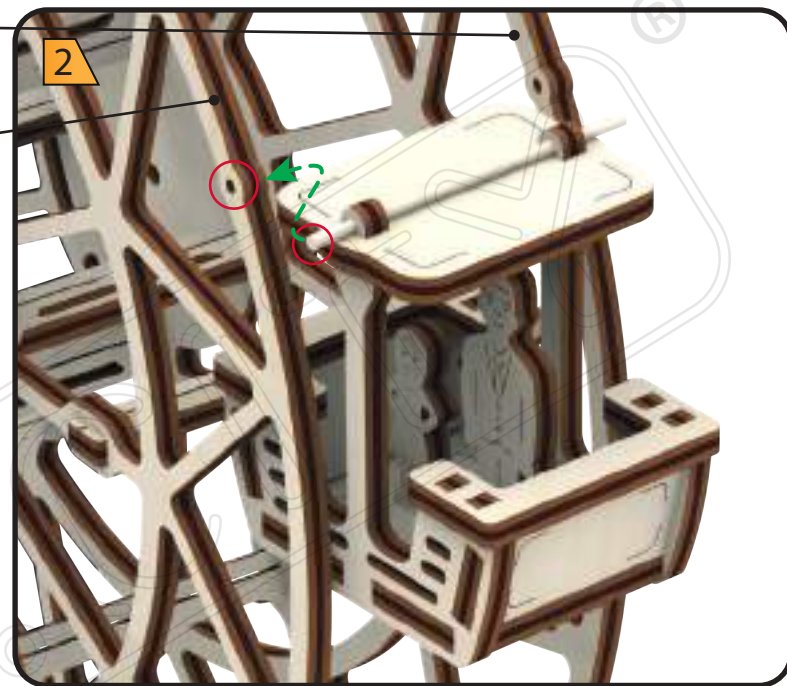

3

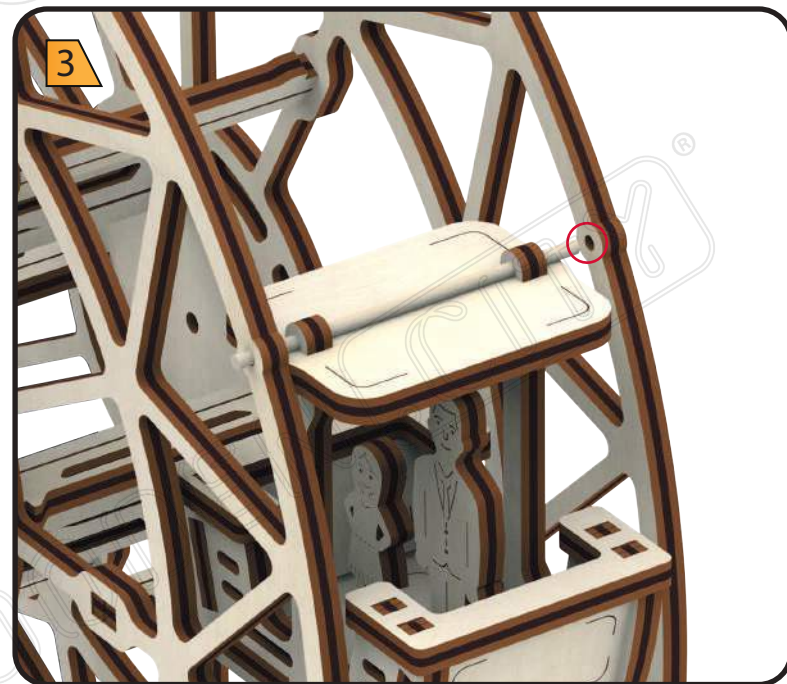

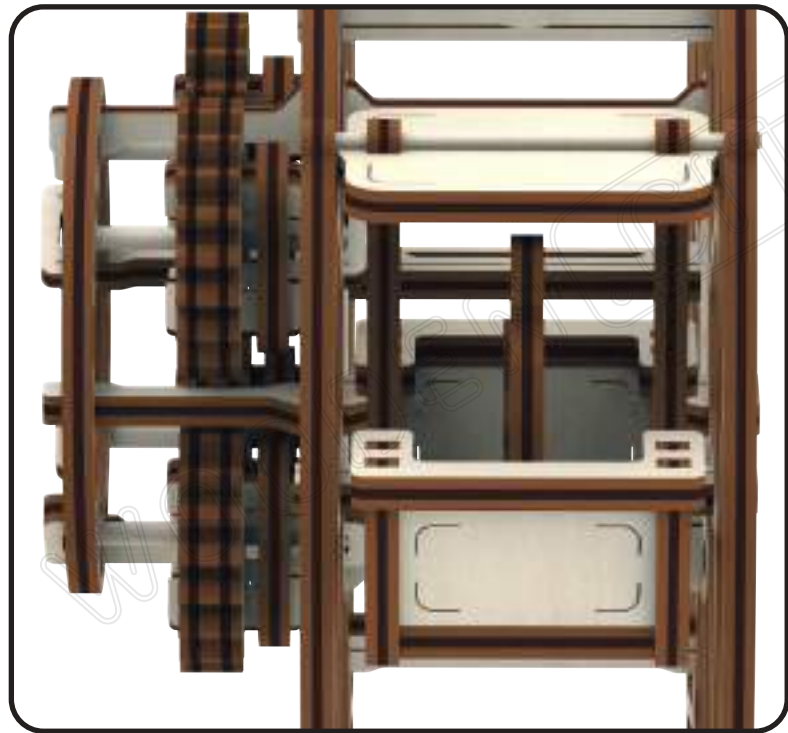

4

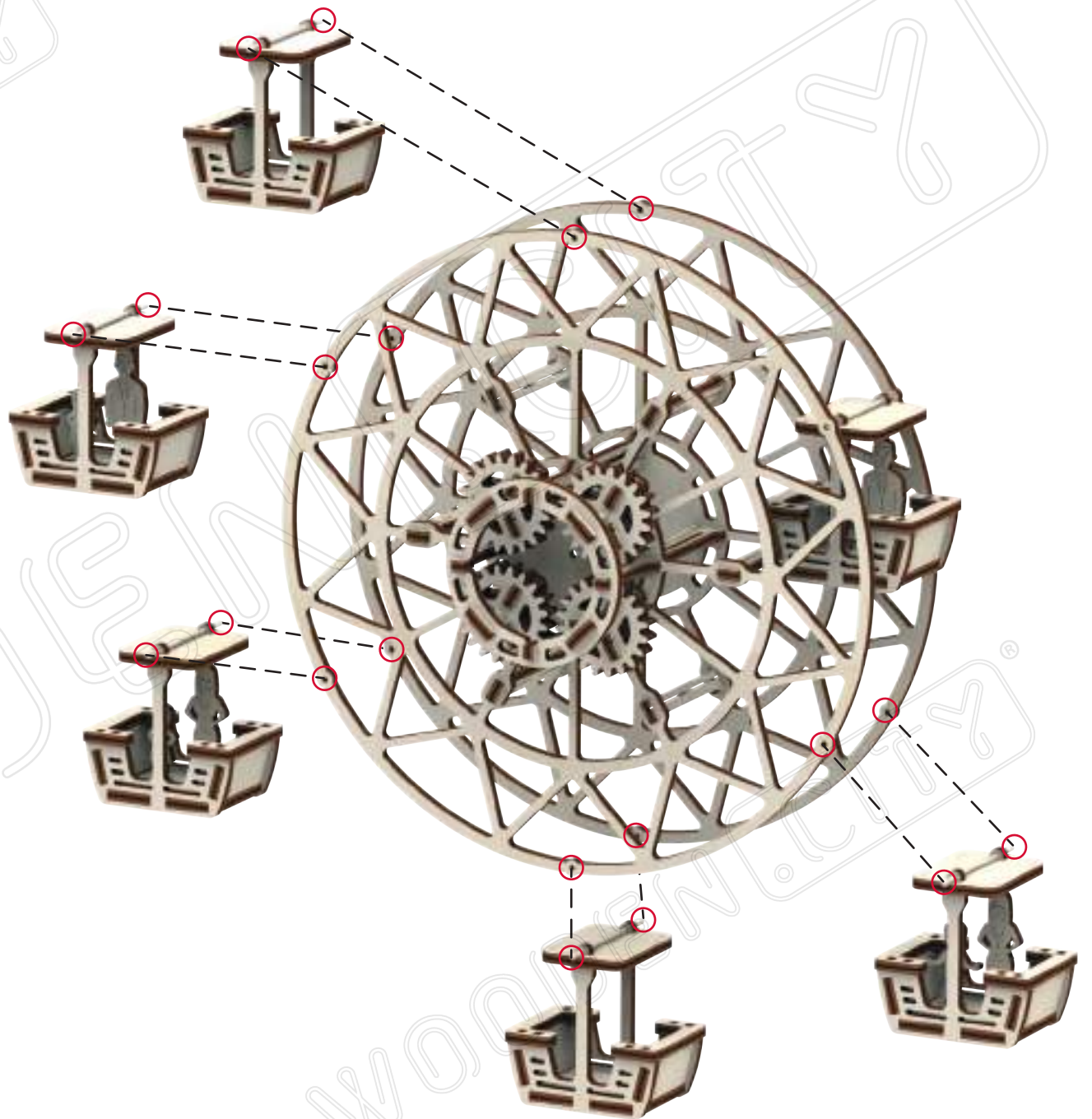

5

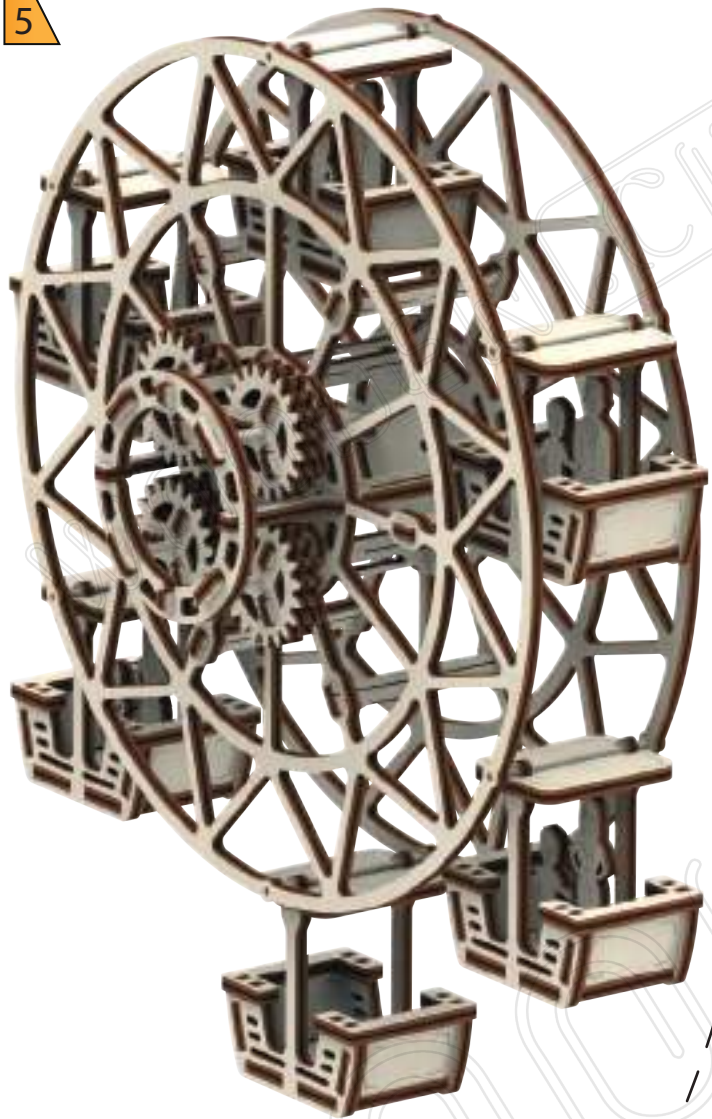

1

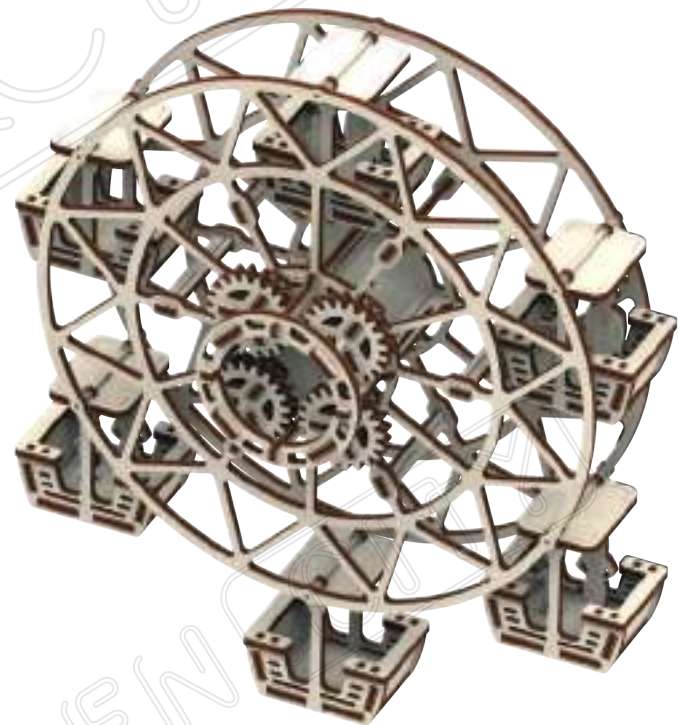
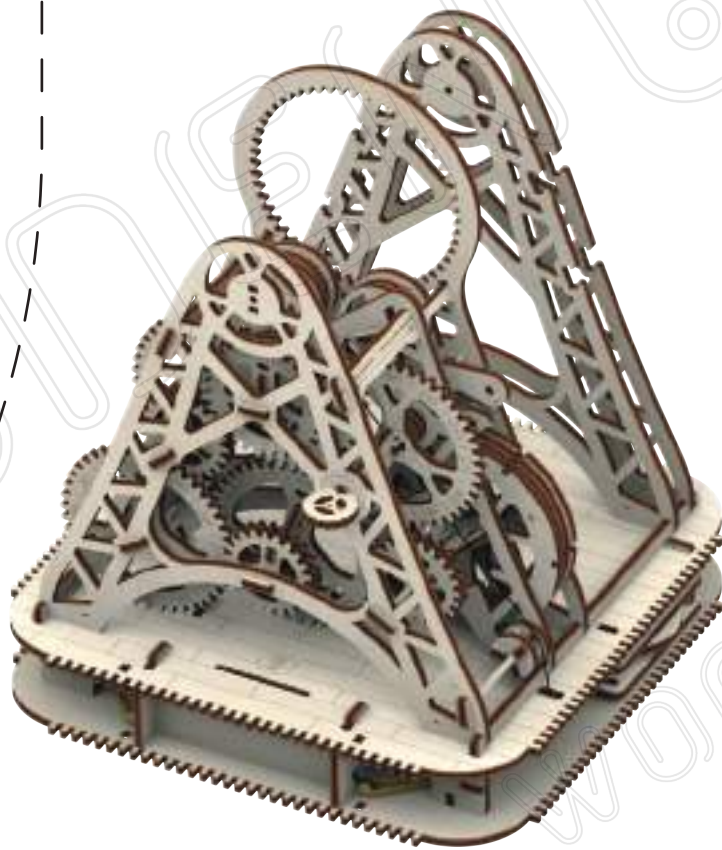

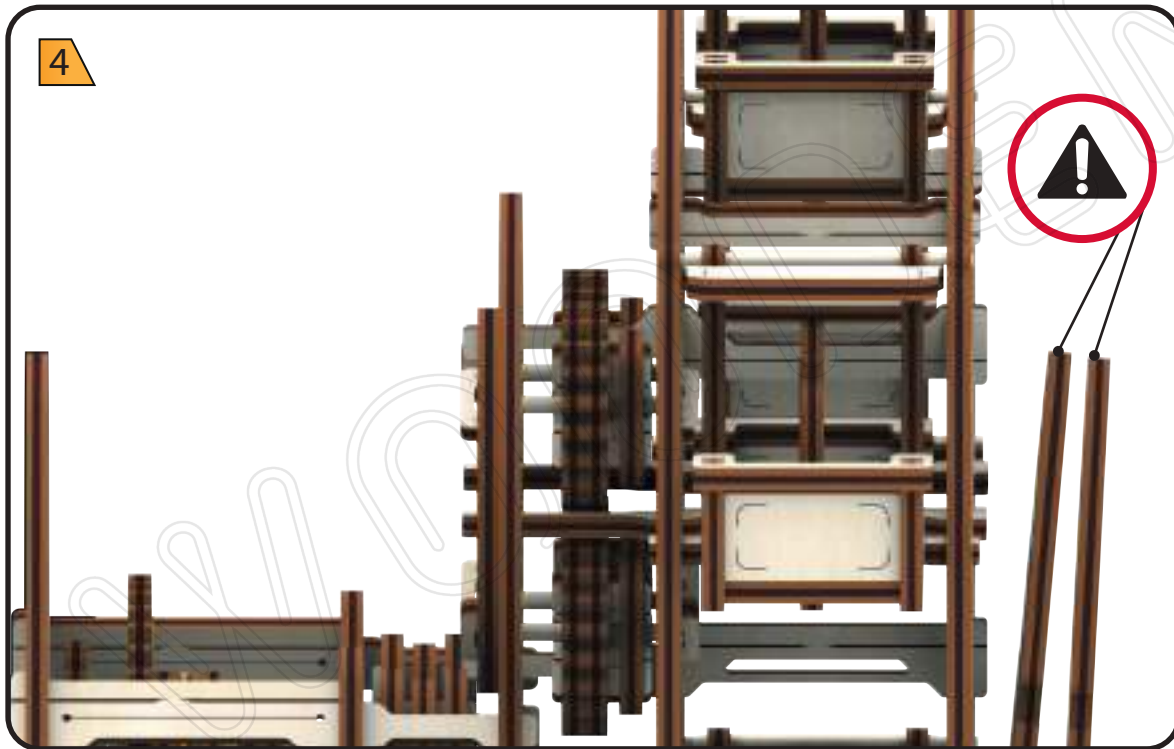
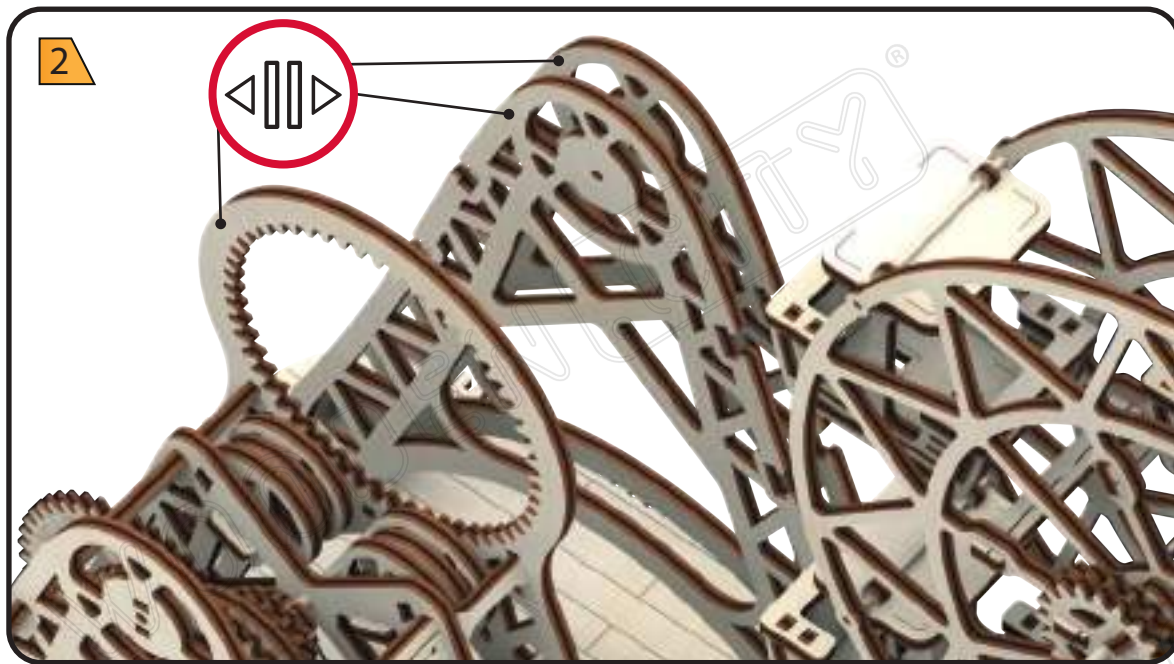

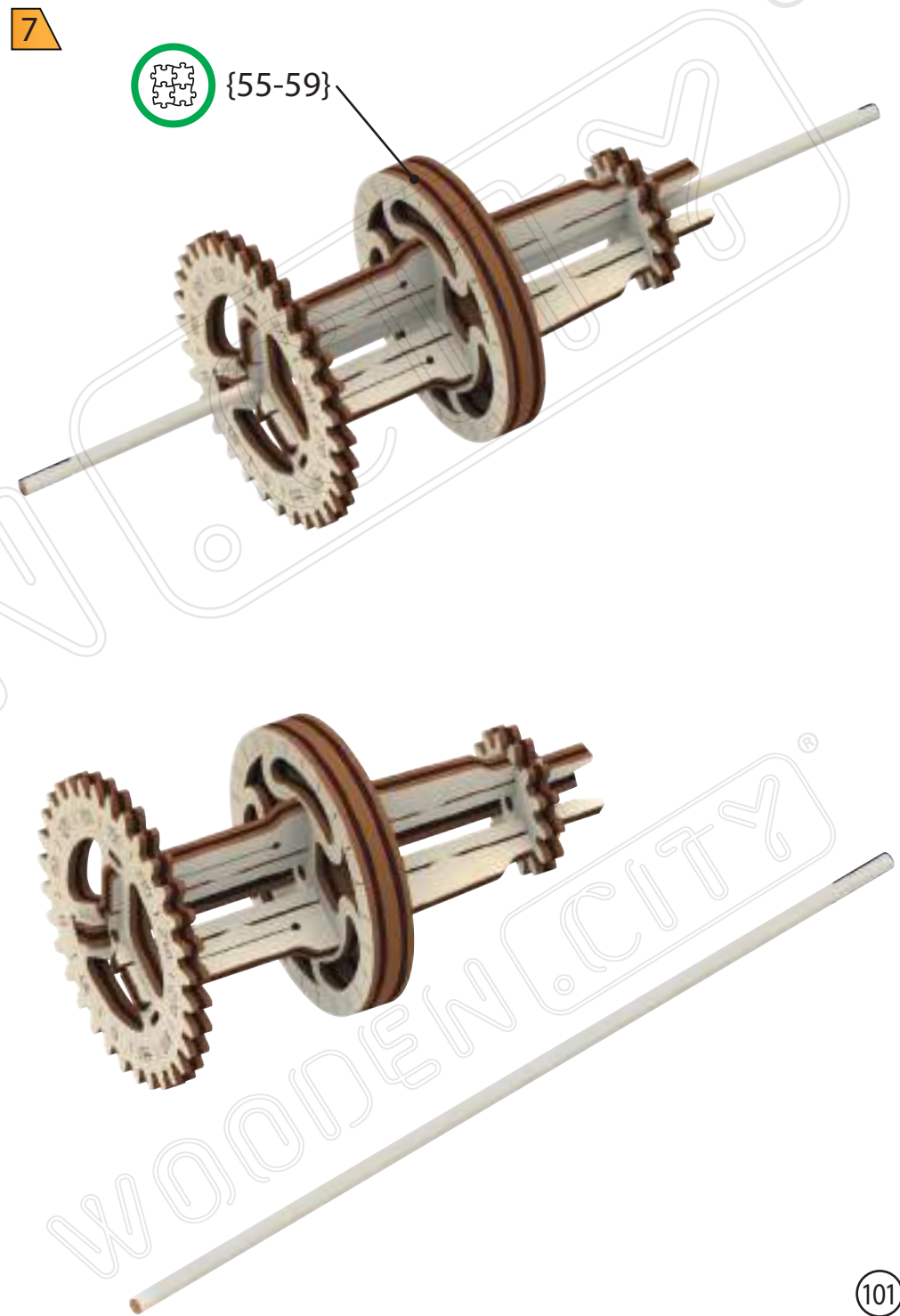
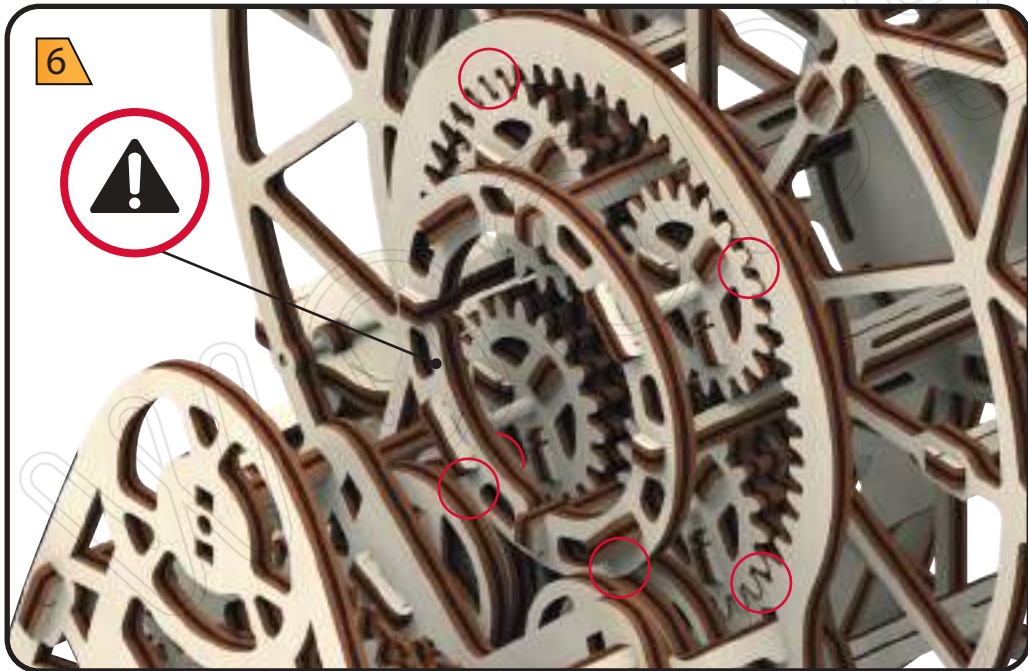

8



9



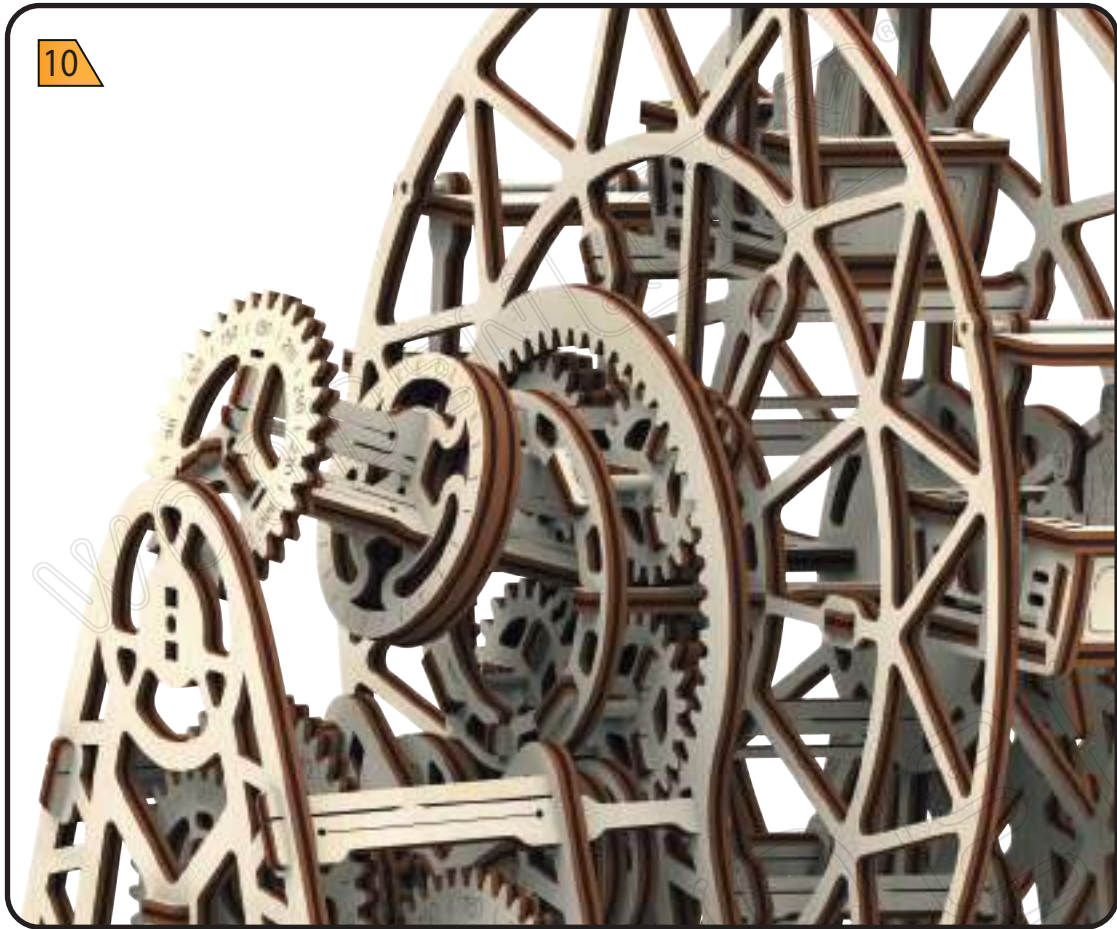

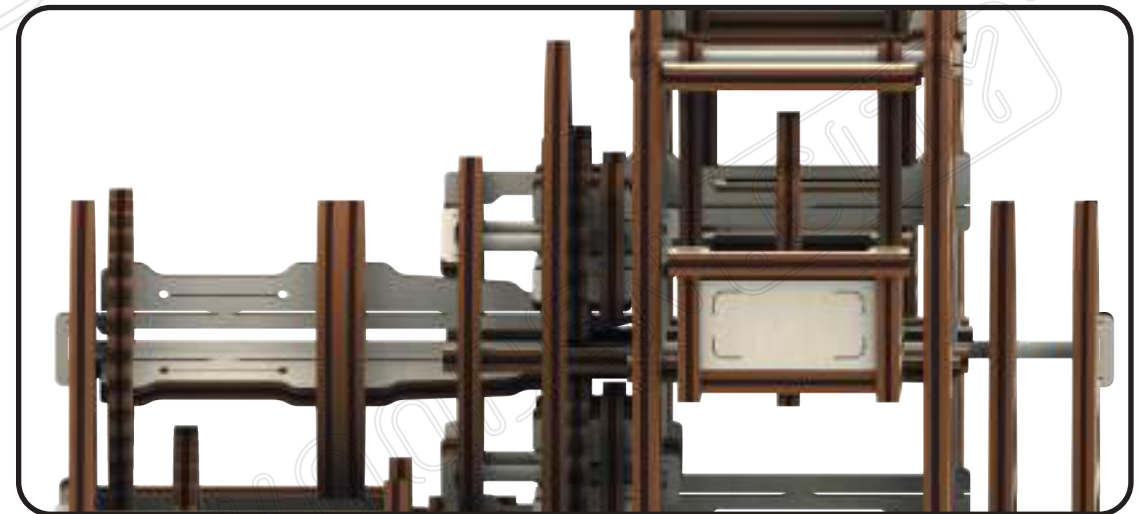
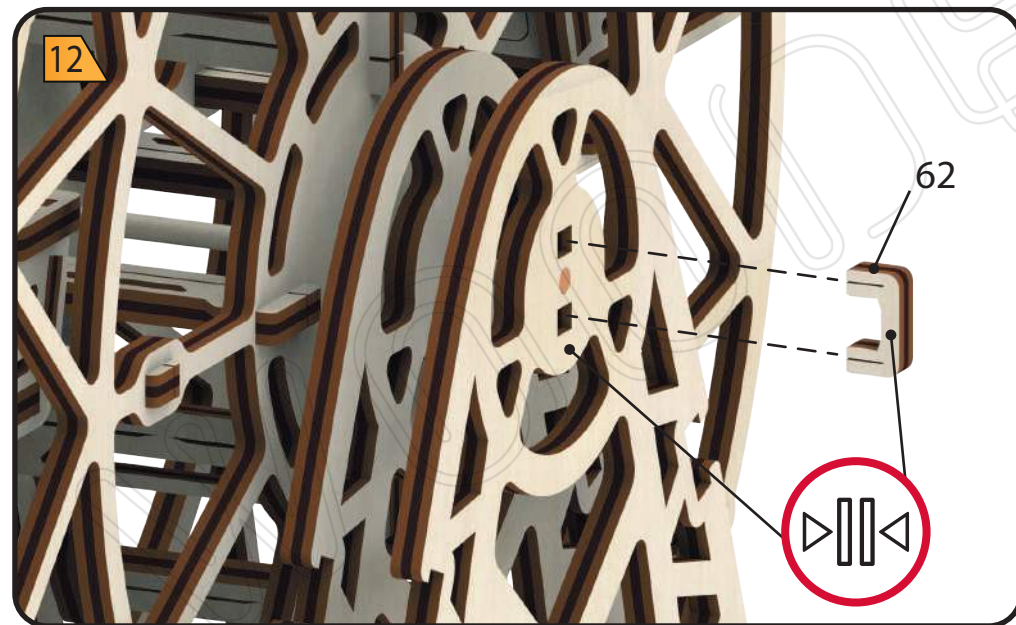
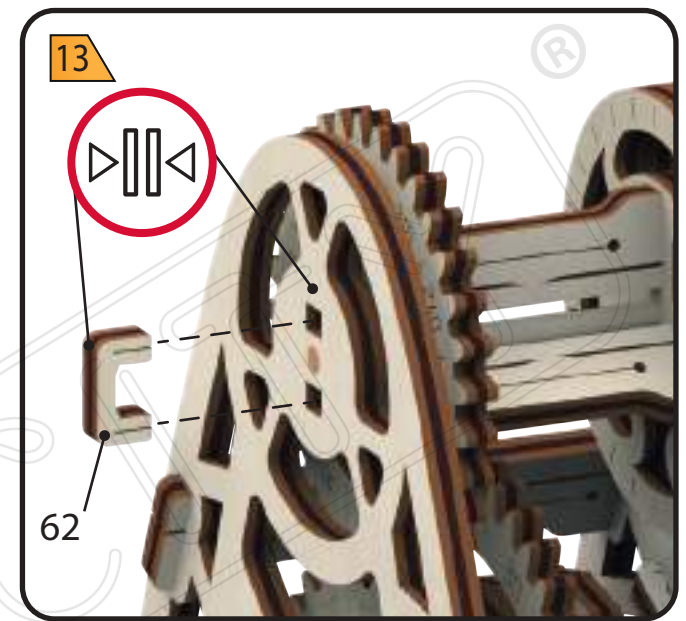
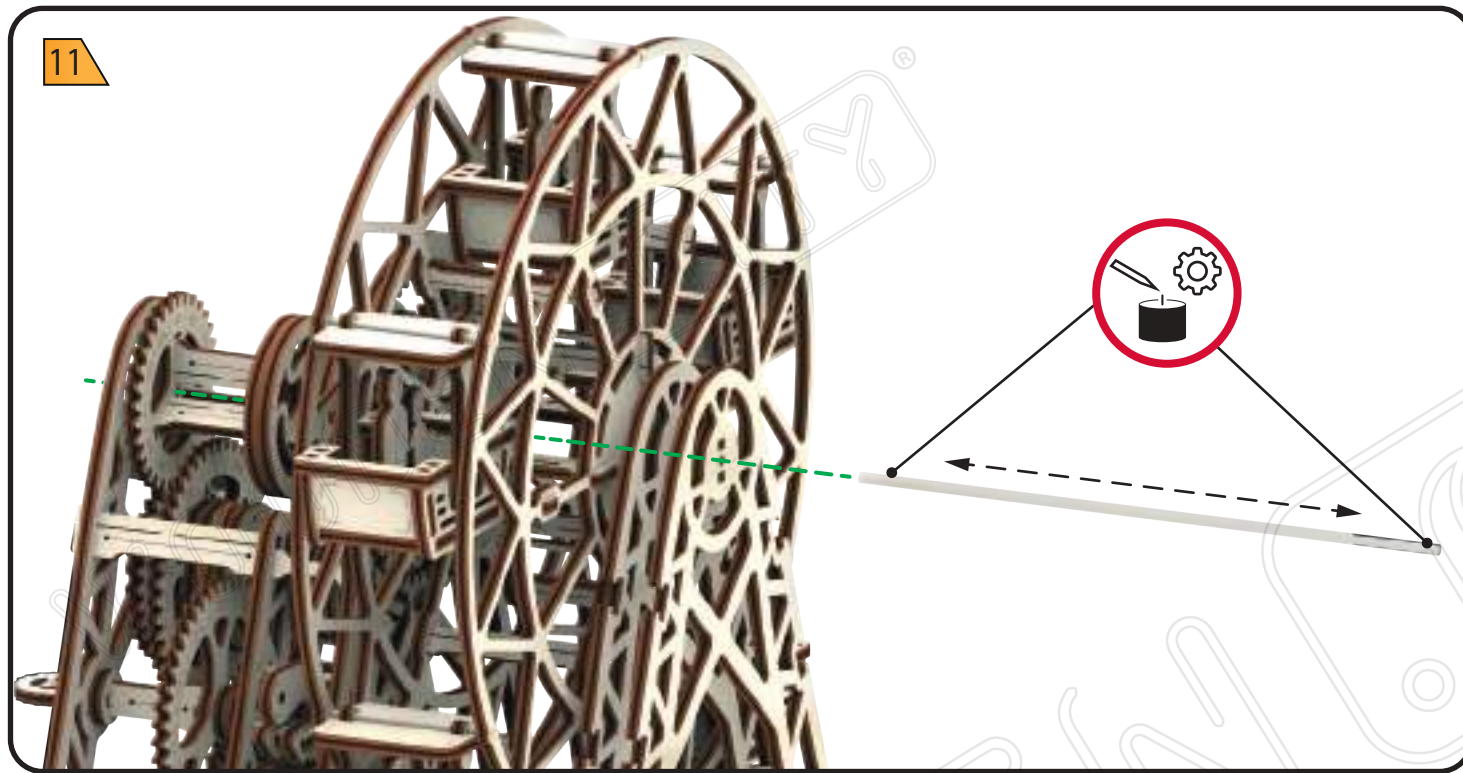

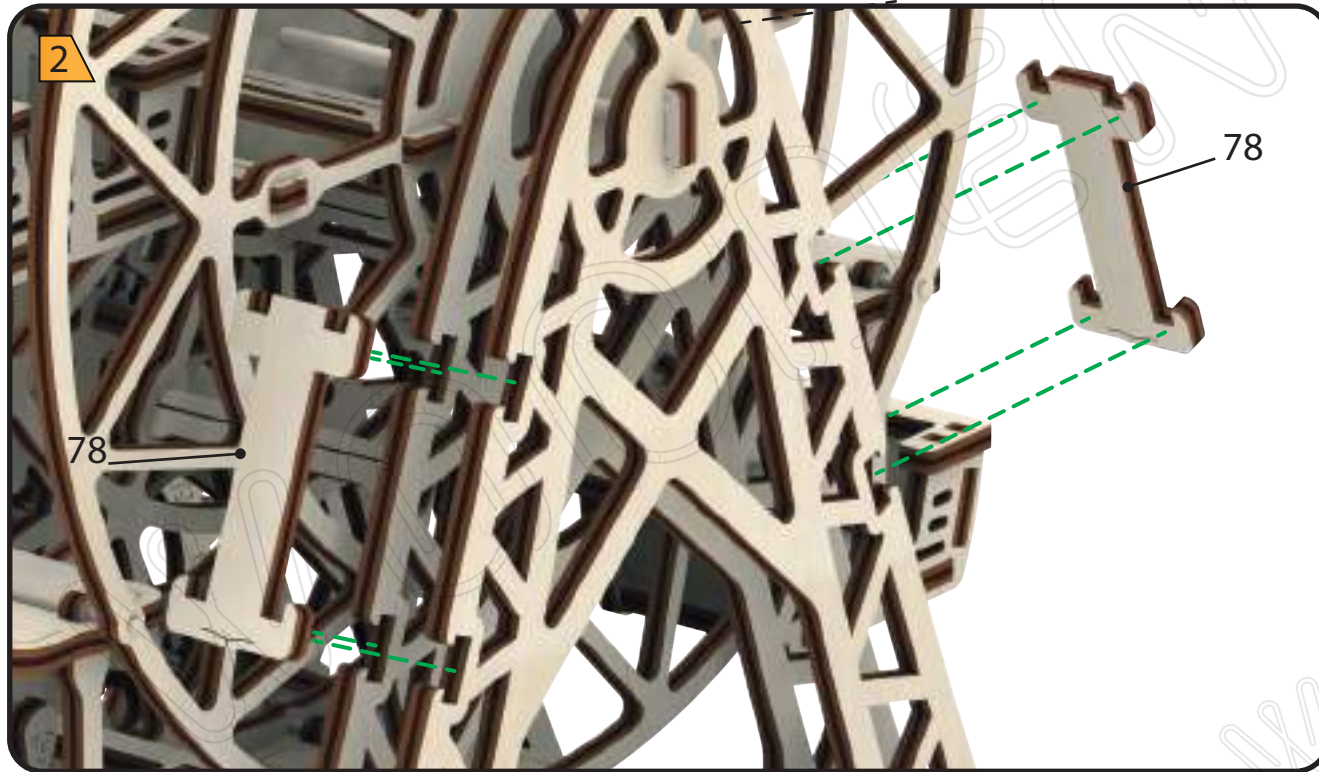
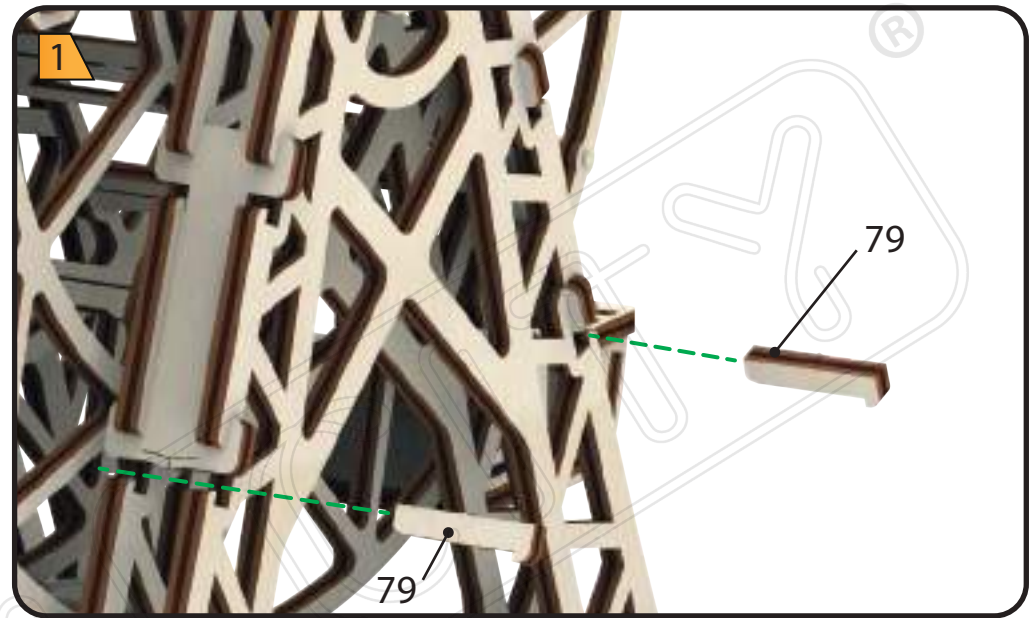
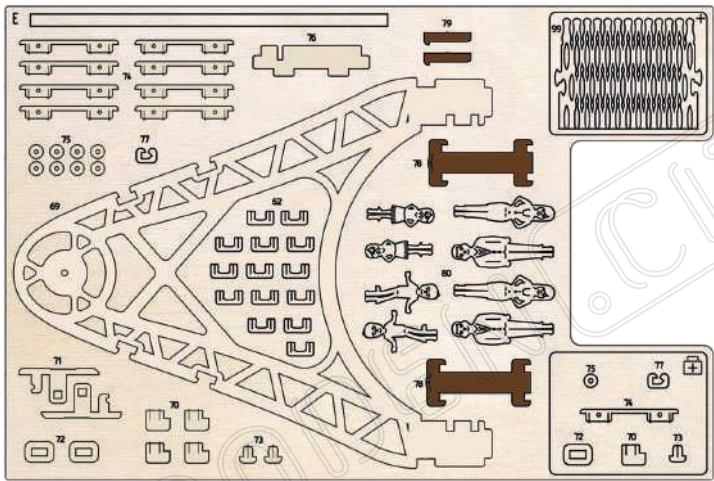

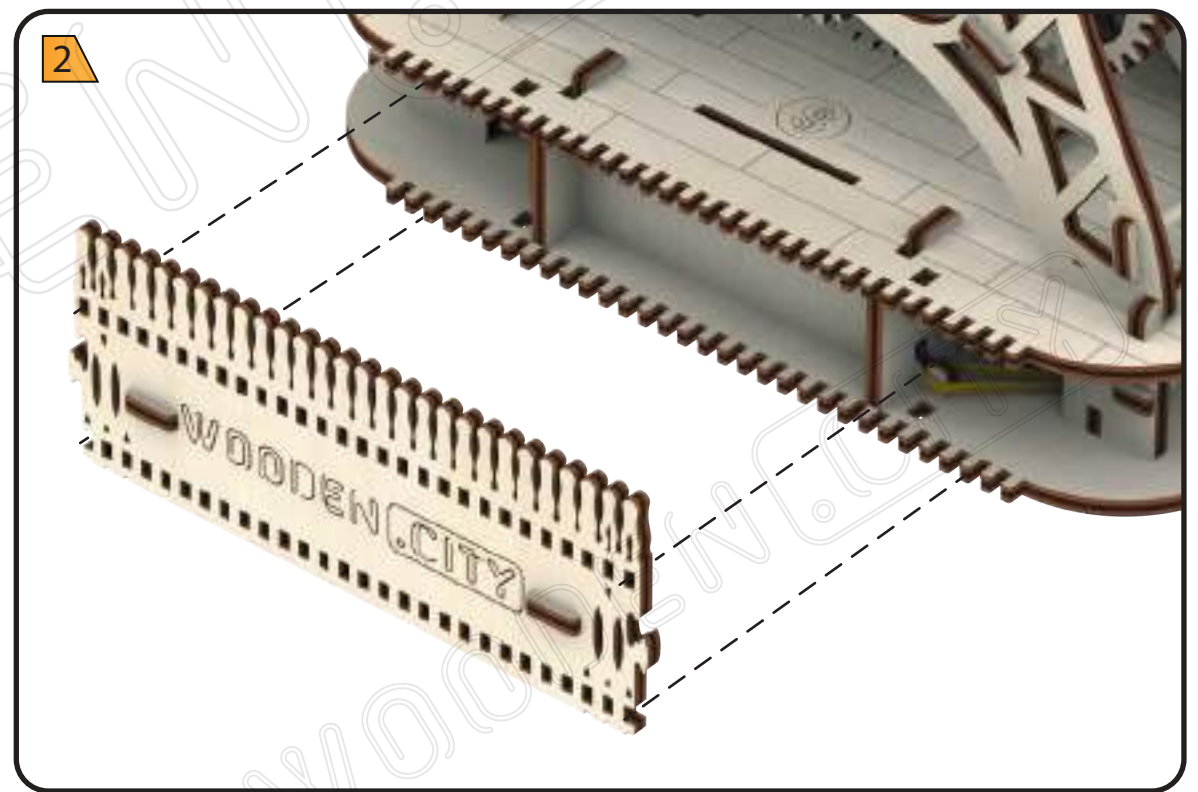
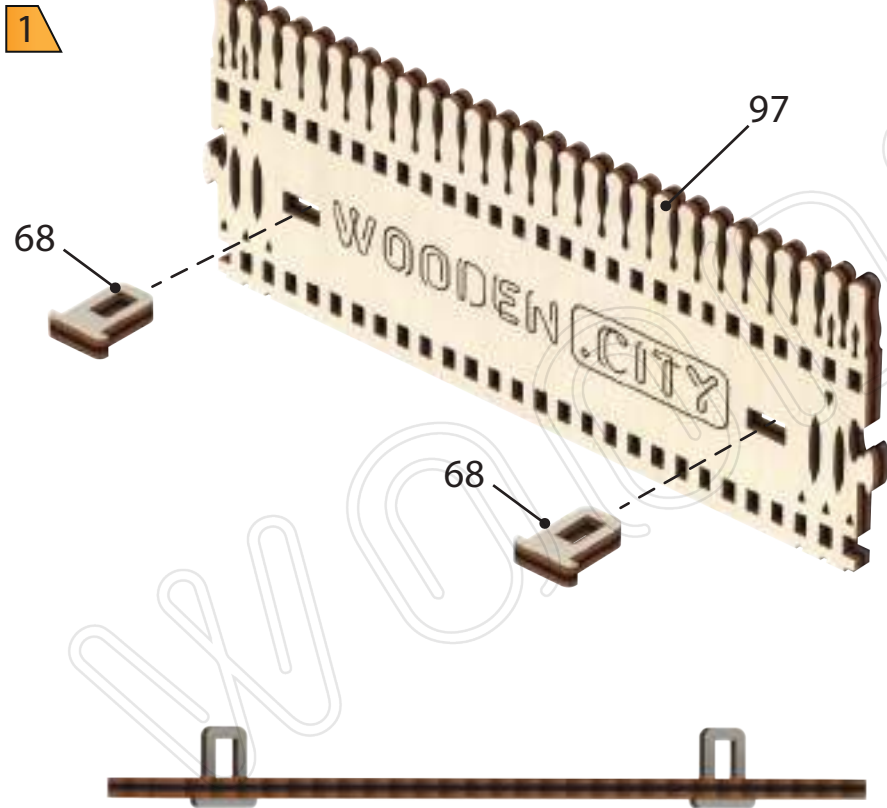
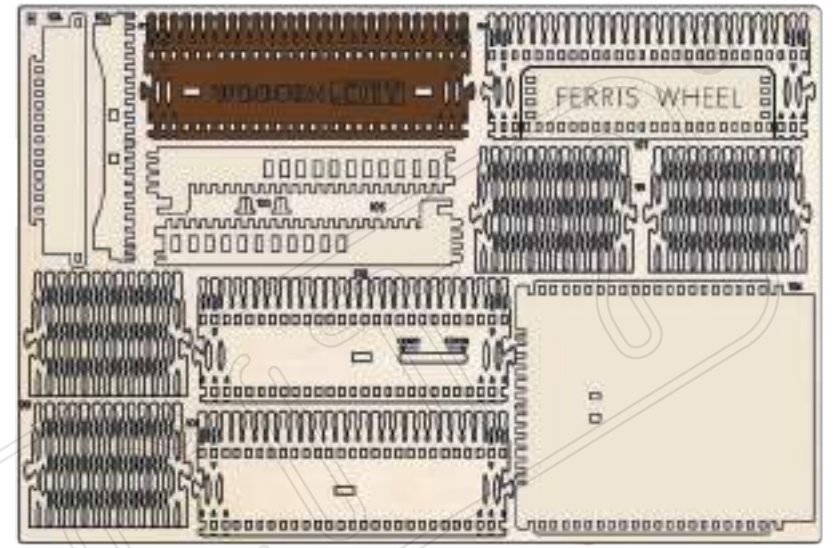
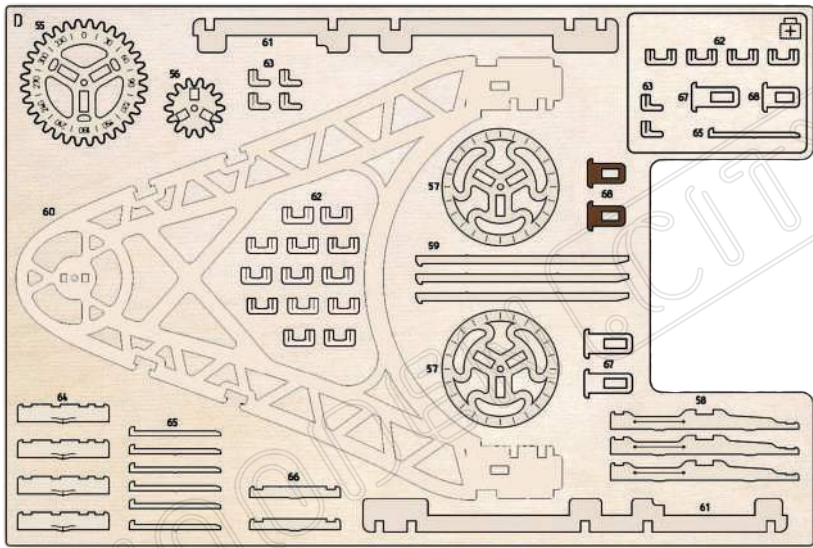

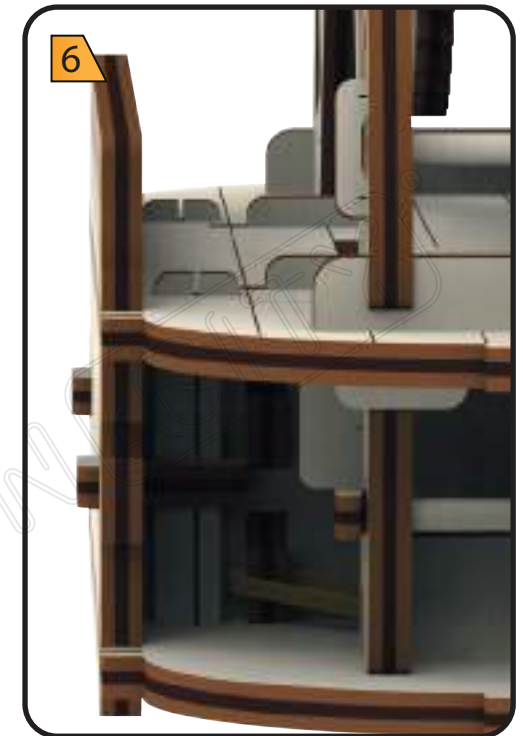
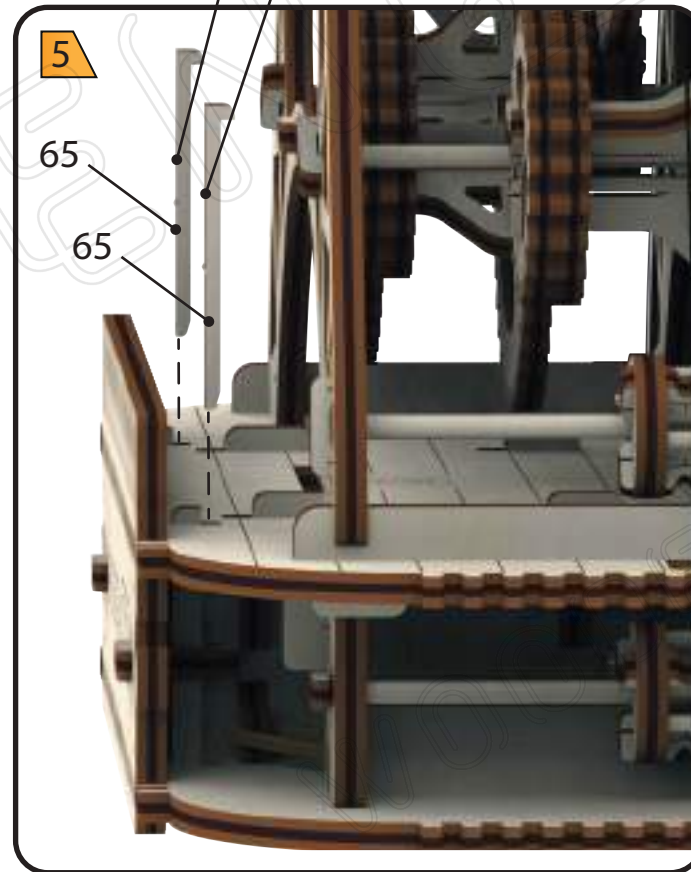
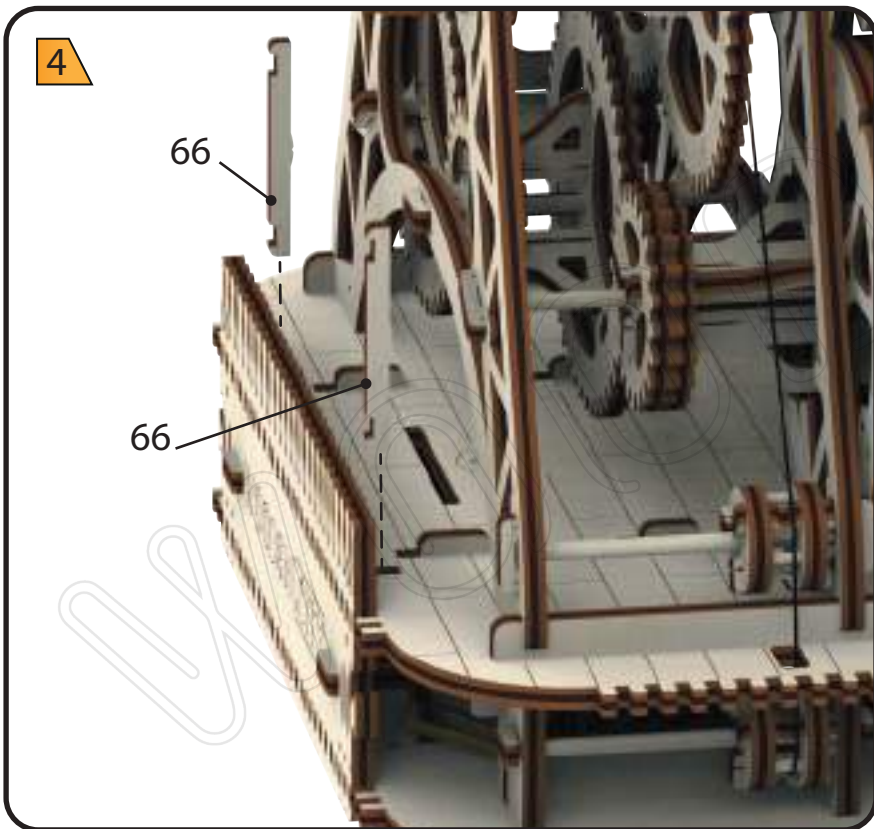
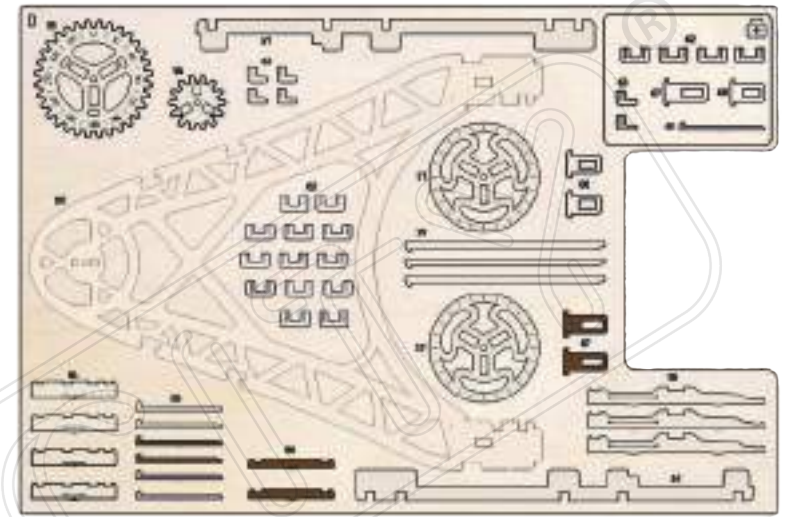
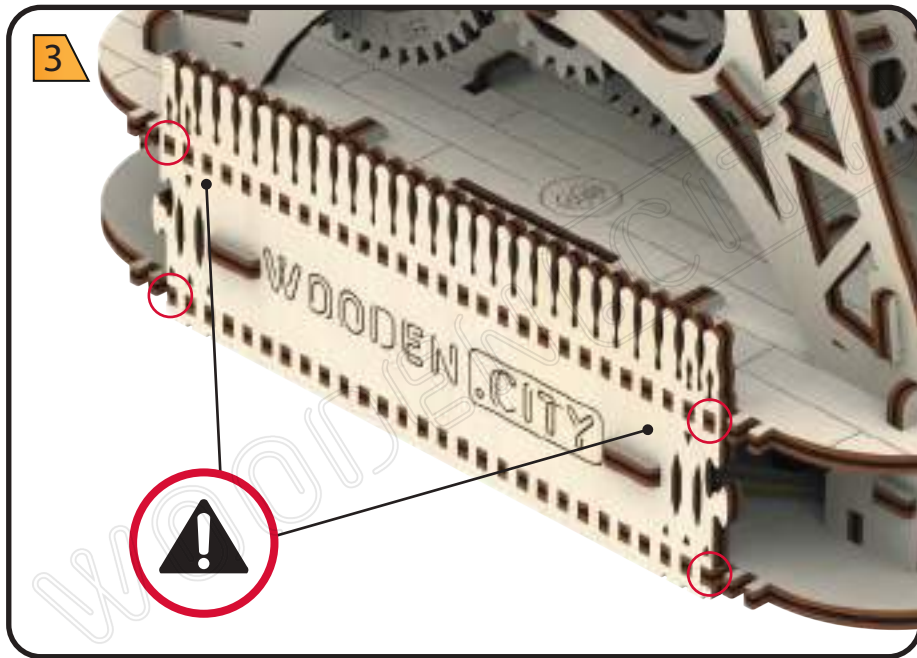

1

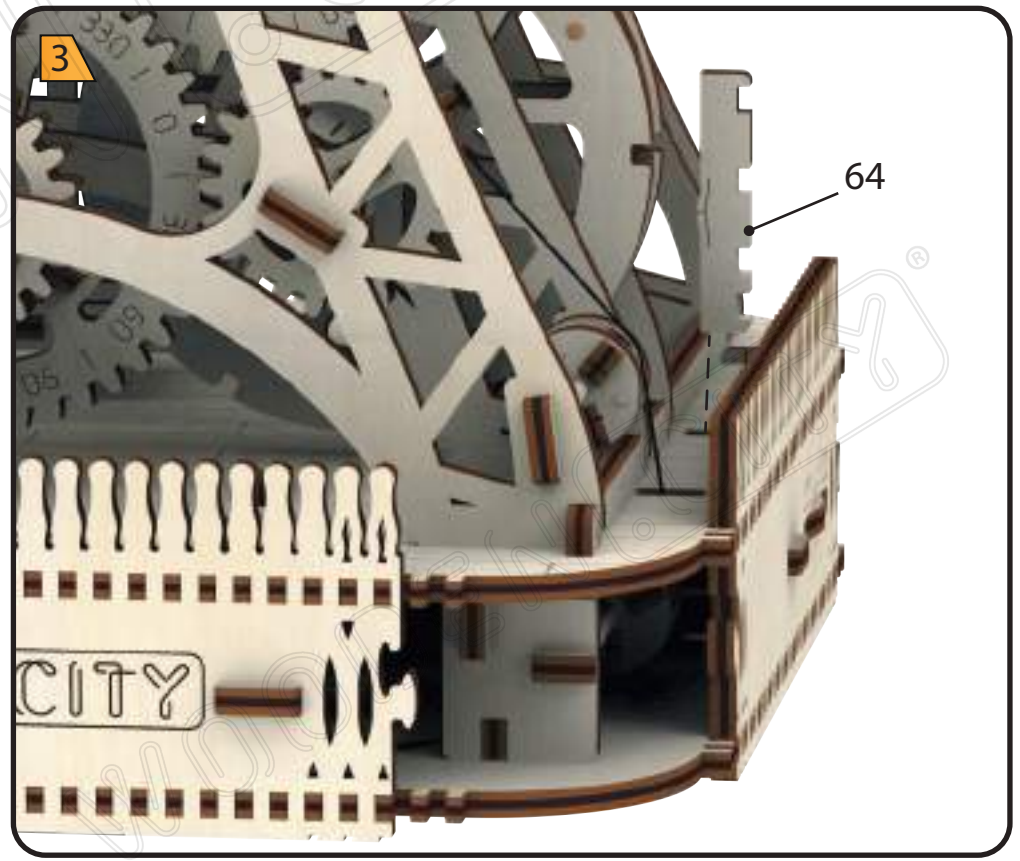
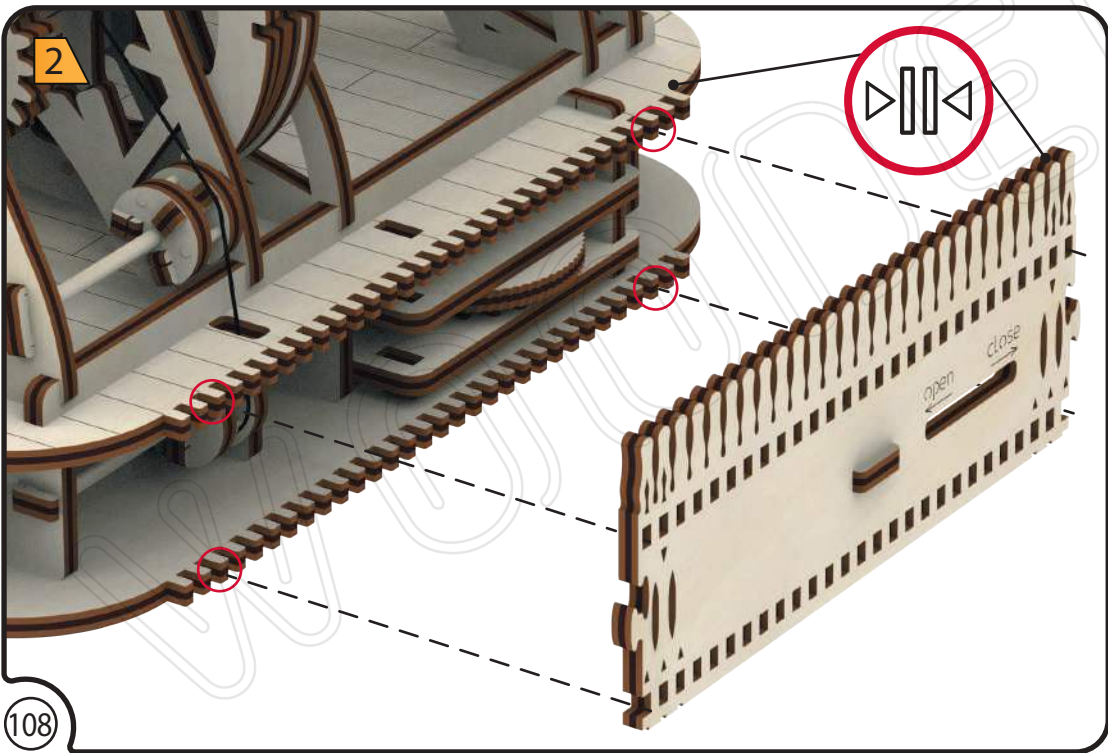
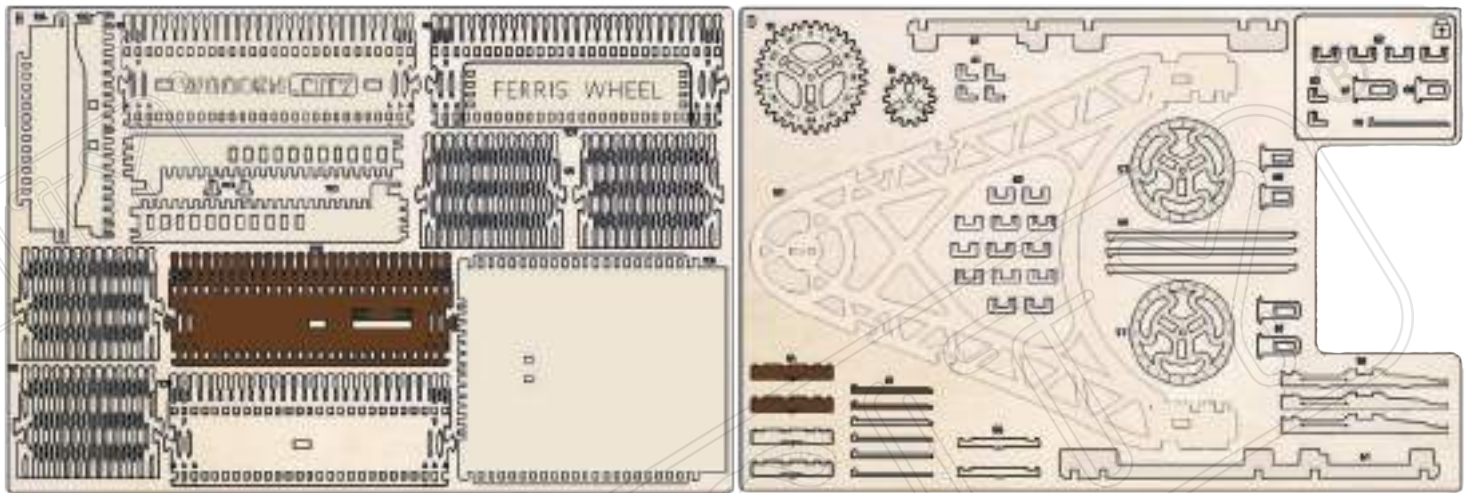
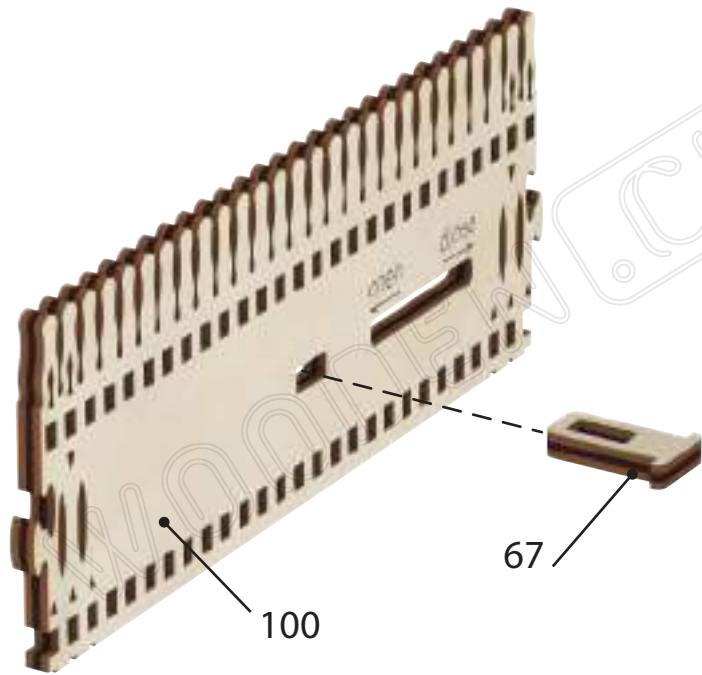

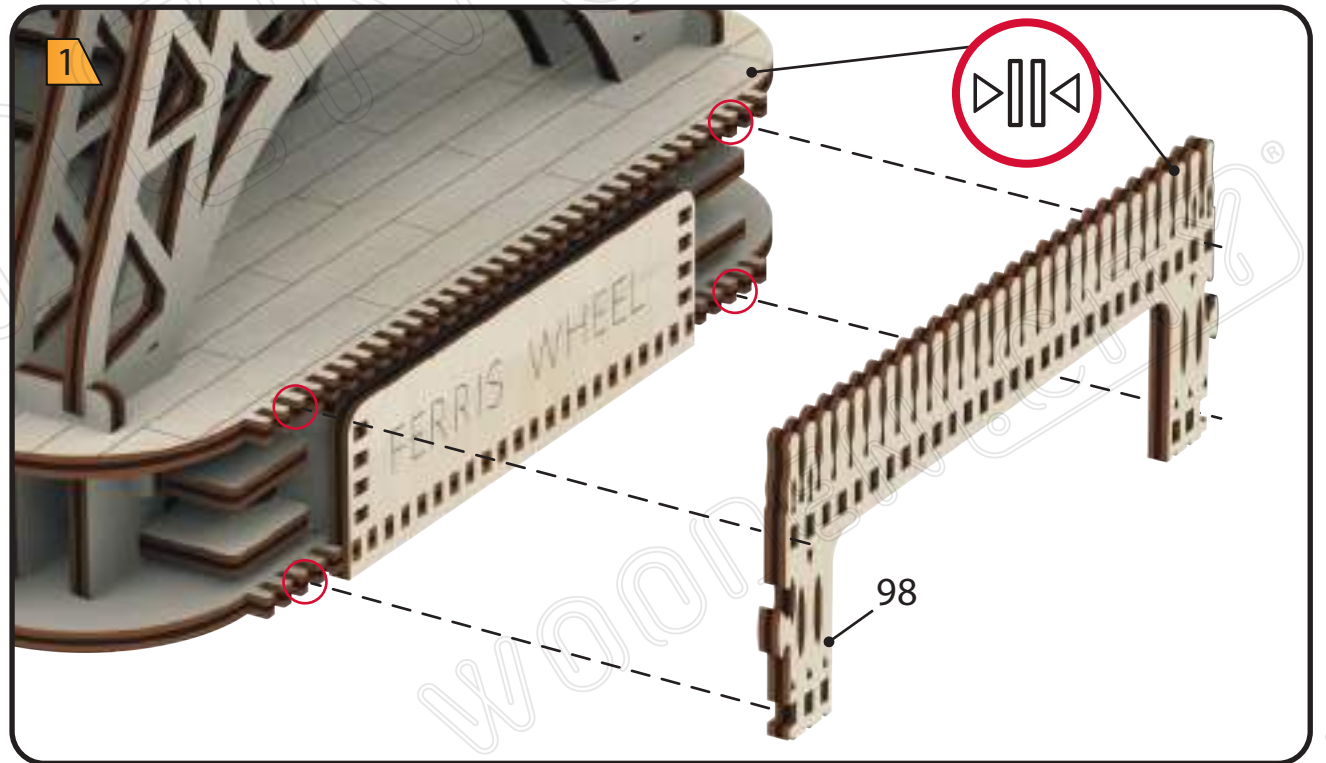
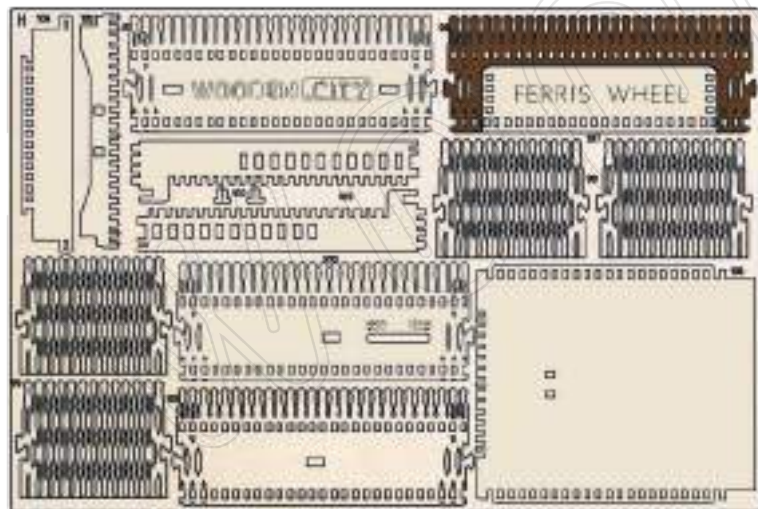
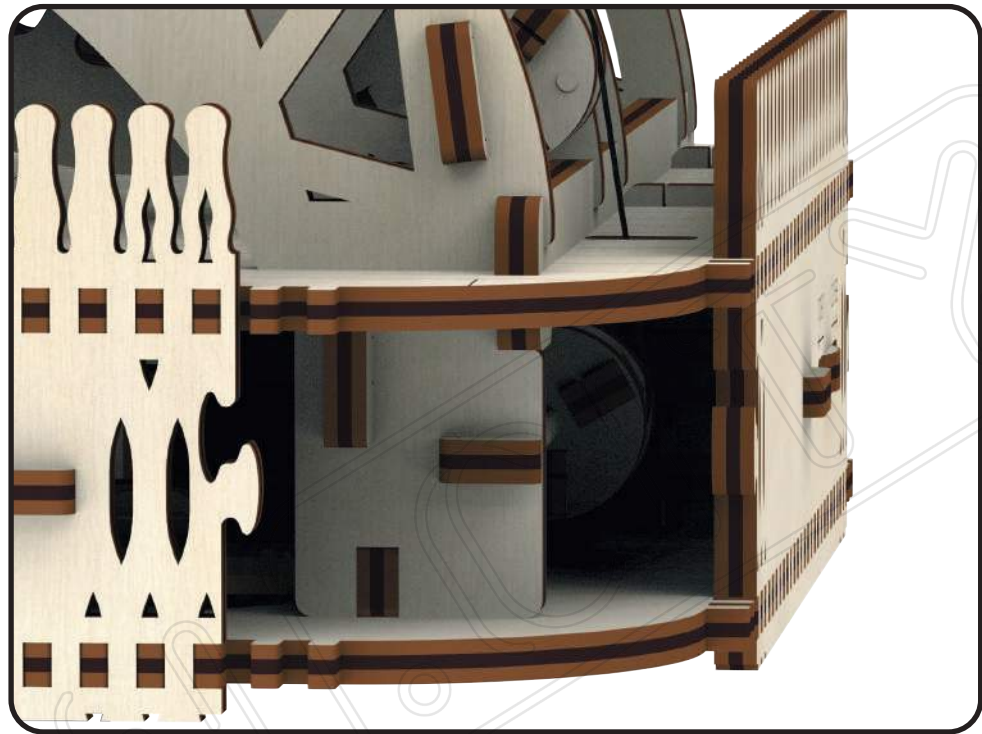
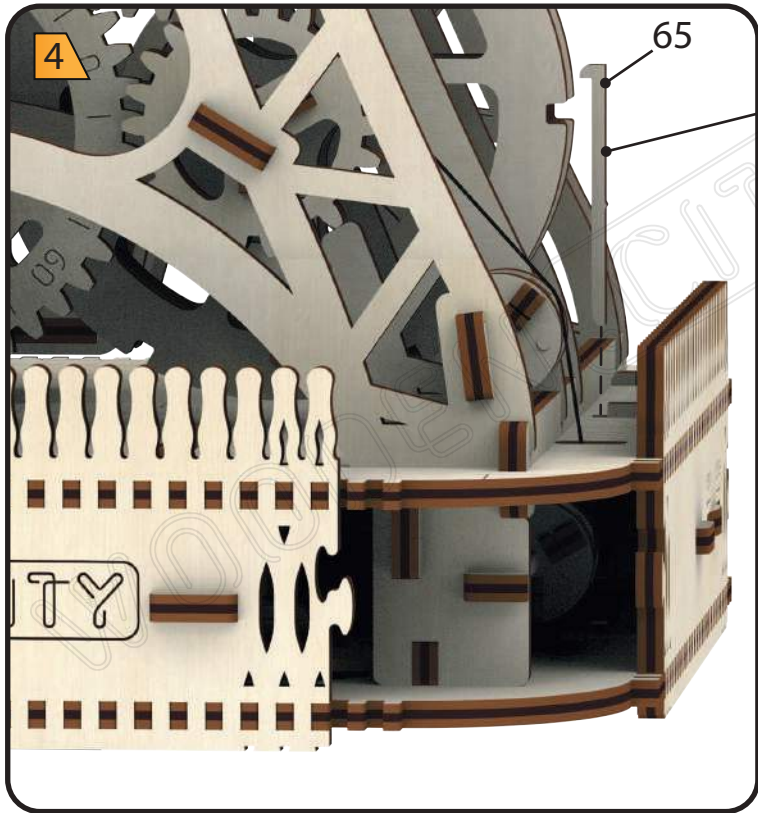

2



1

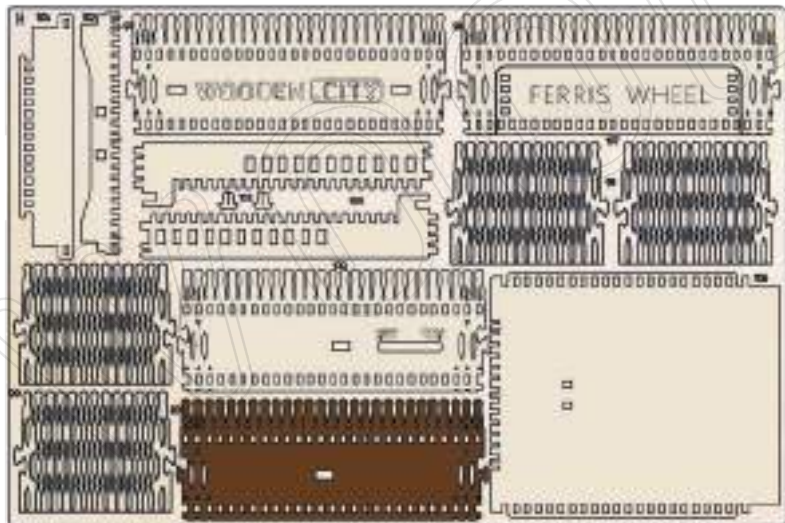

101

67

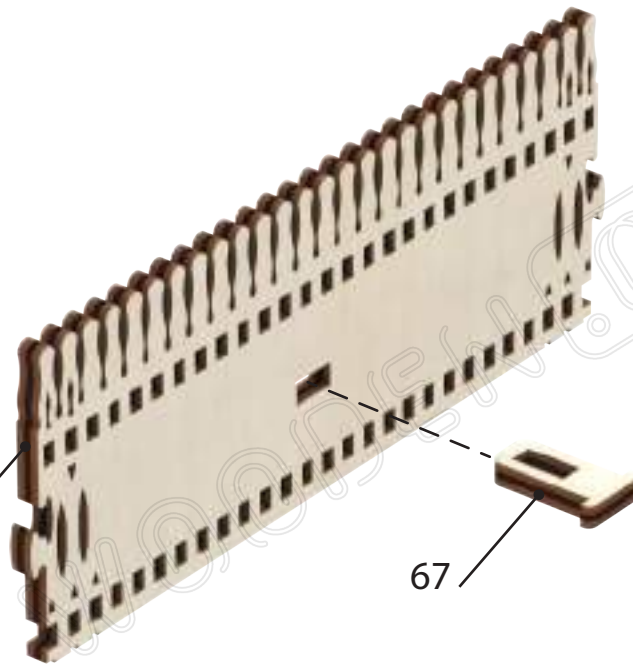

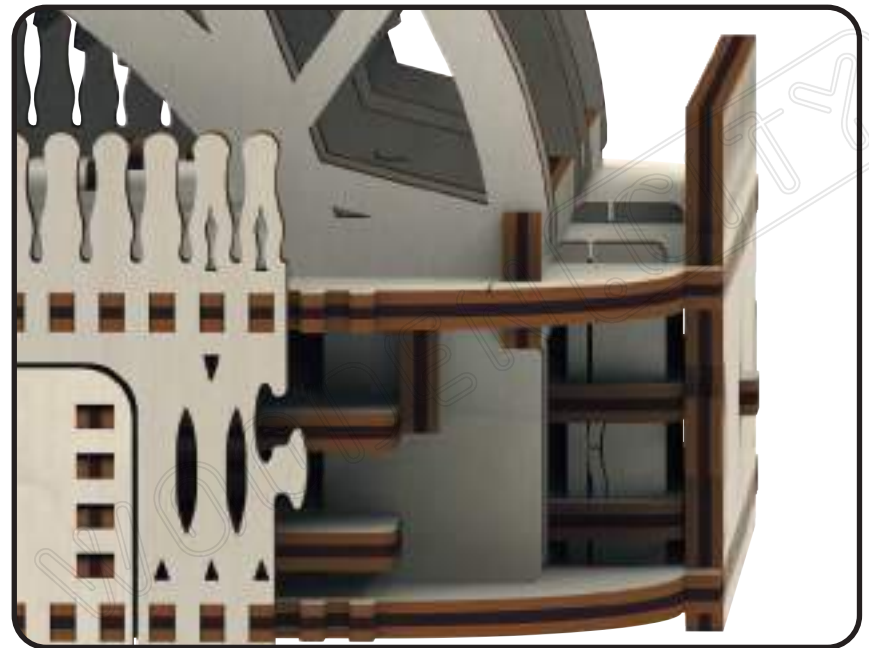
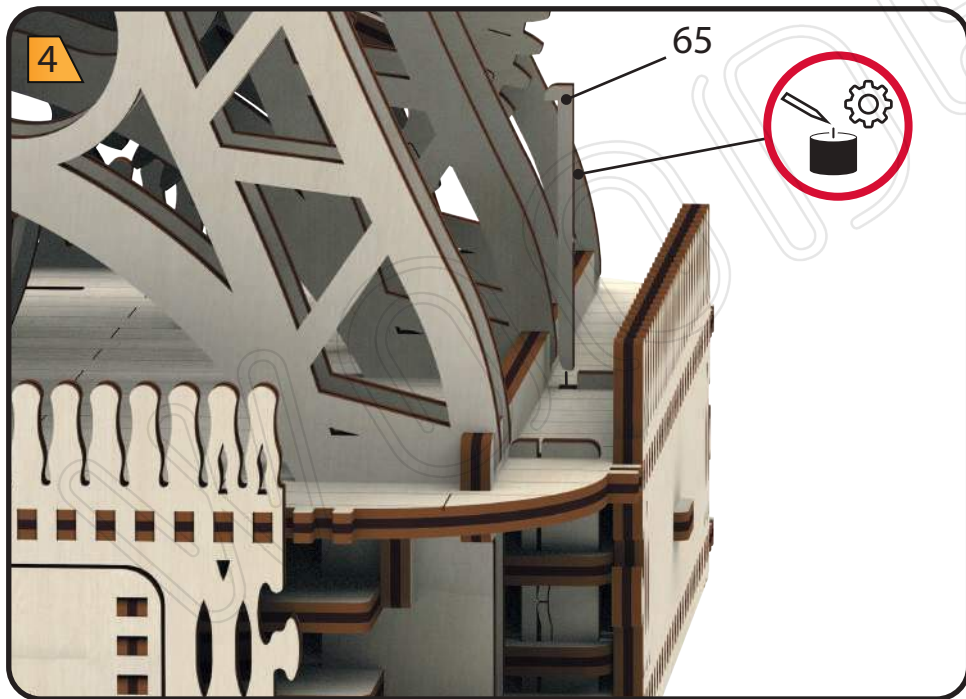
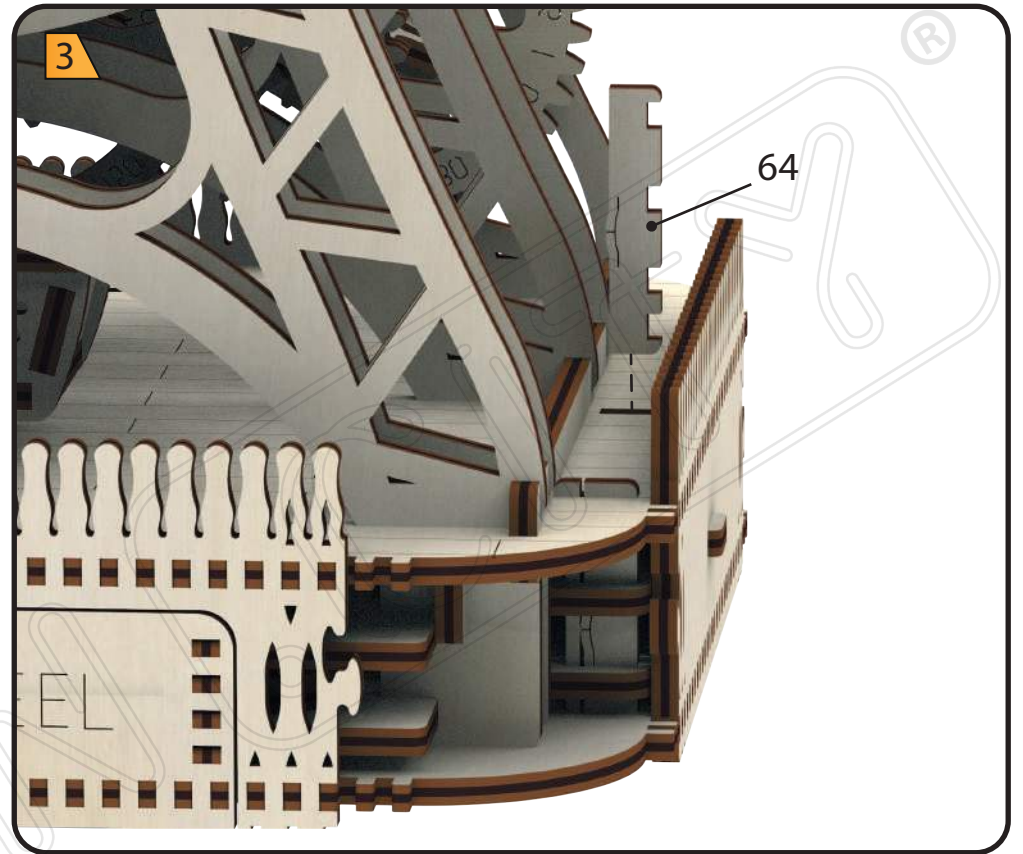
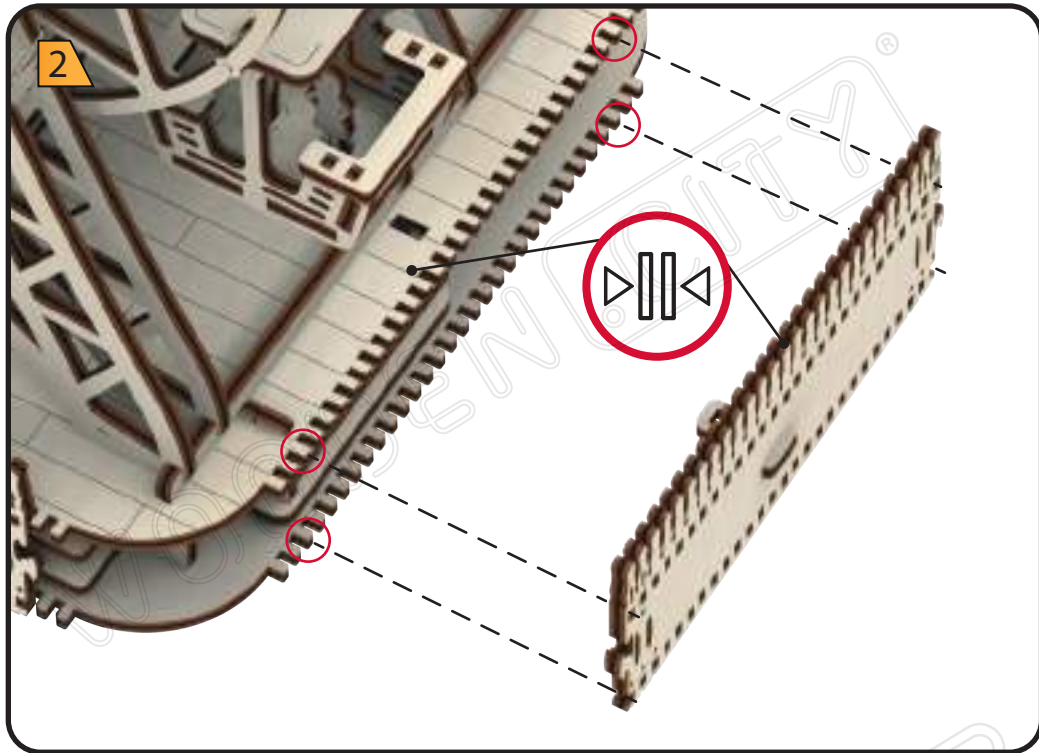

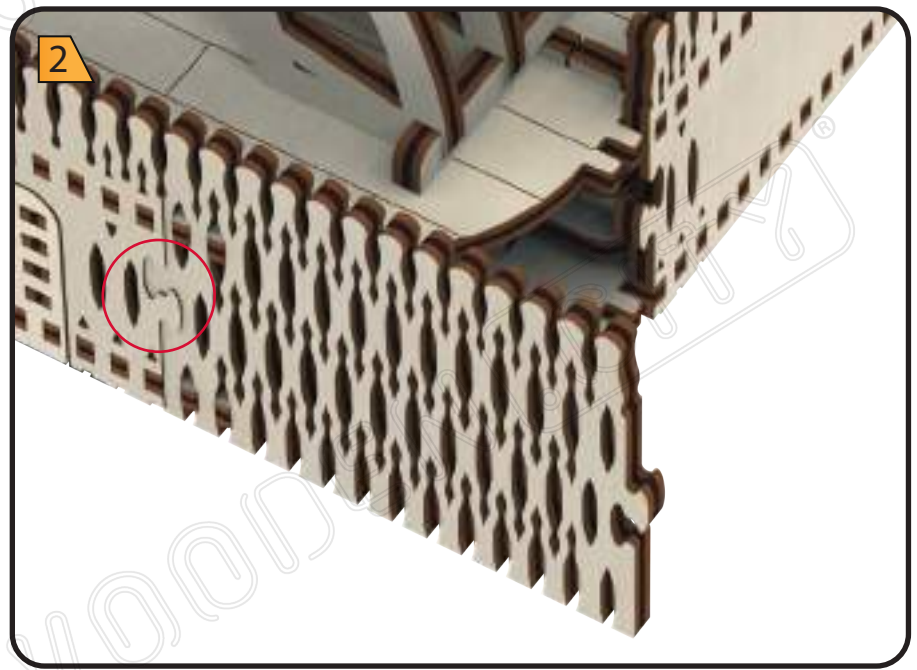
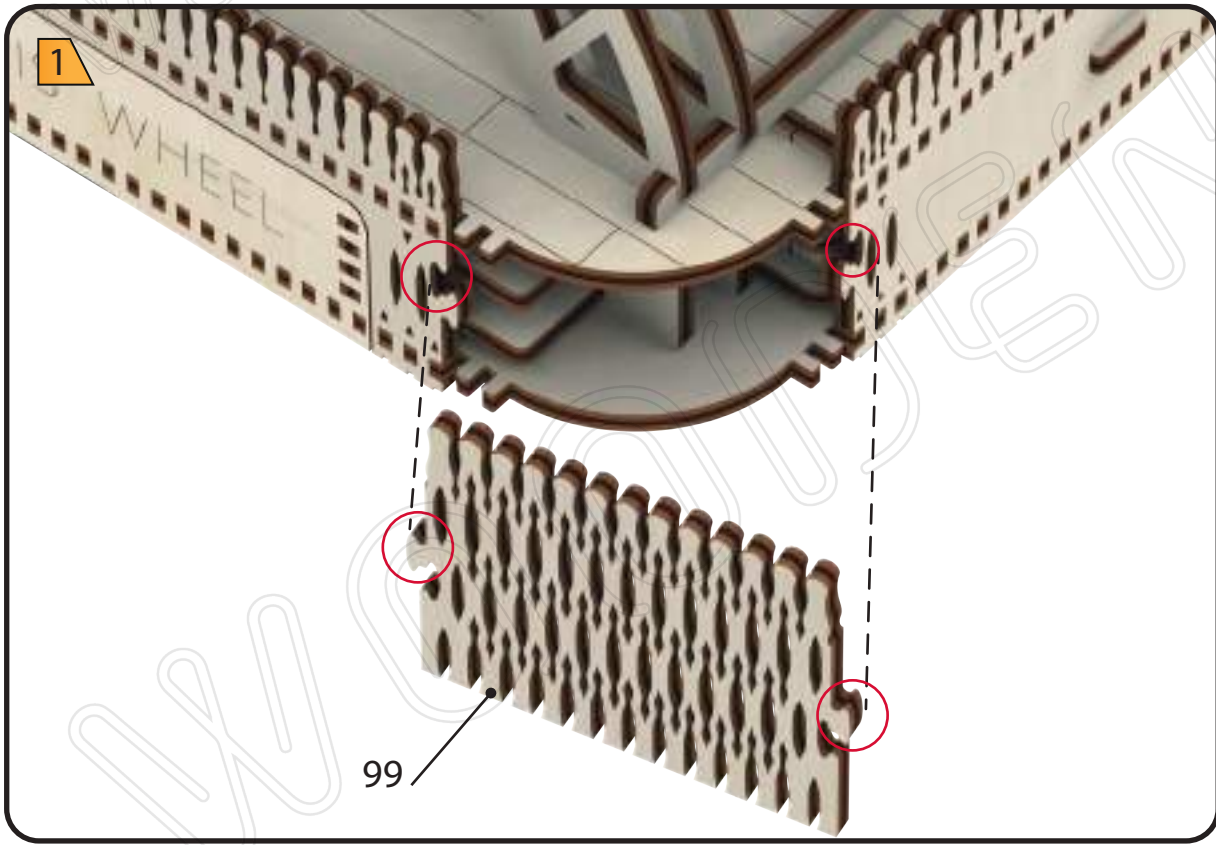
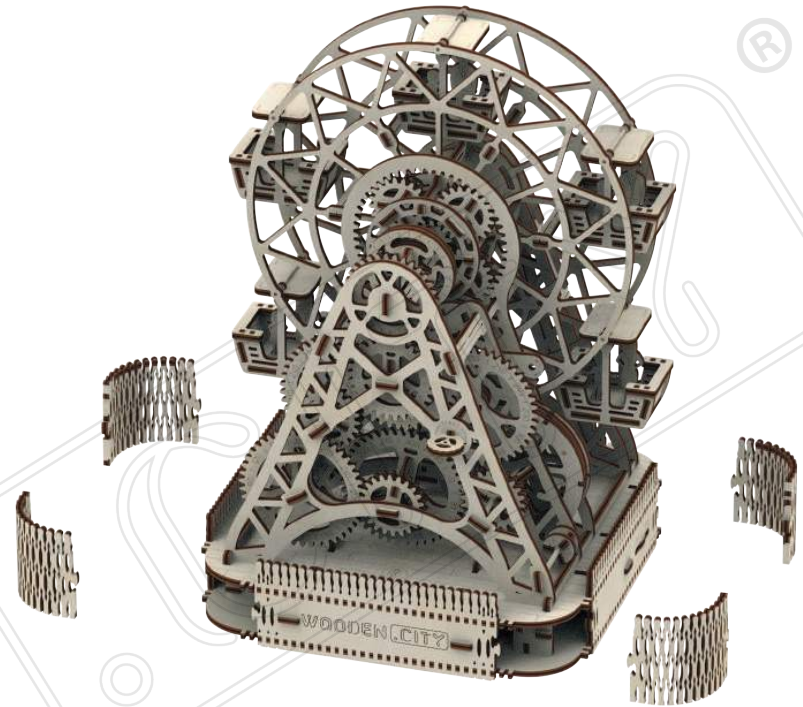
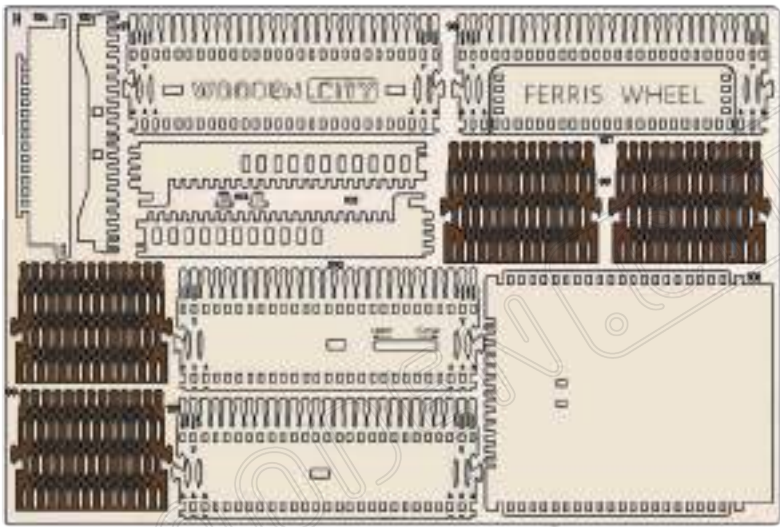

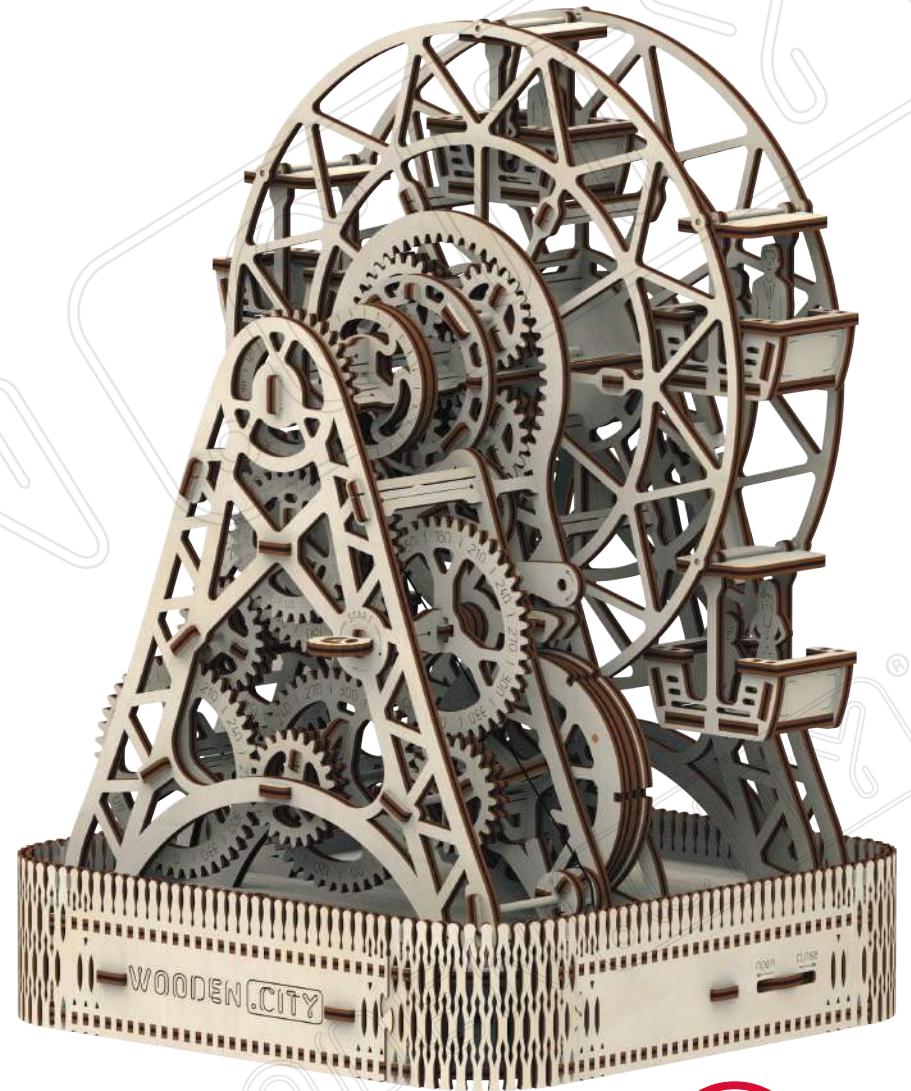
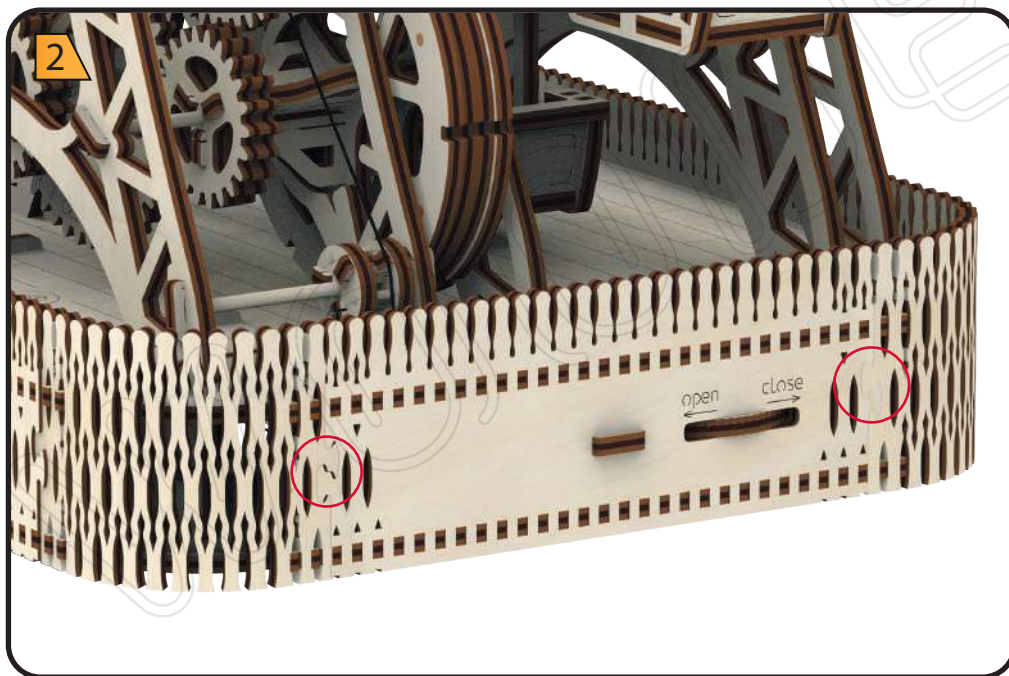
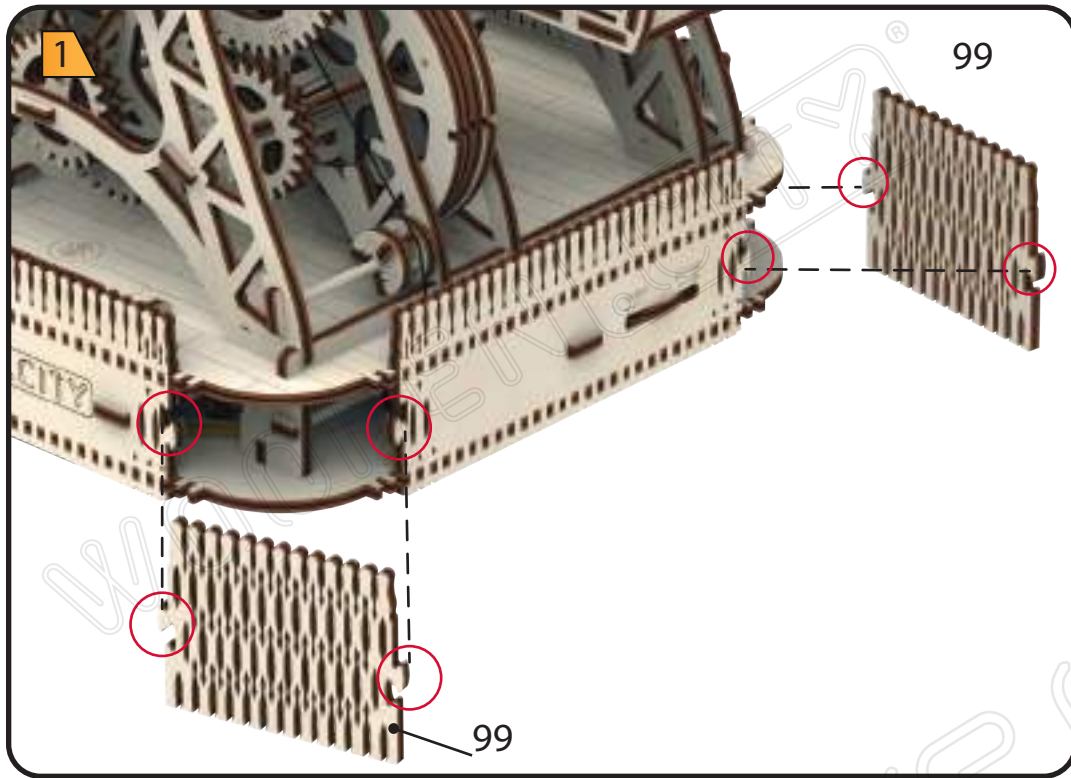

480 min

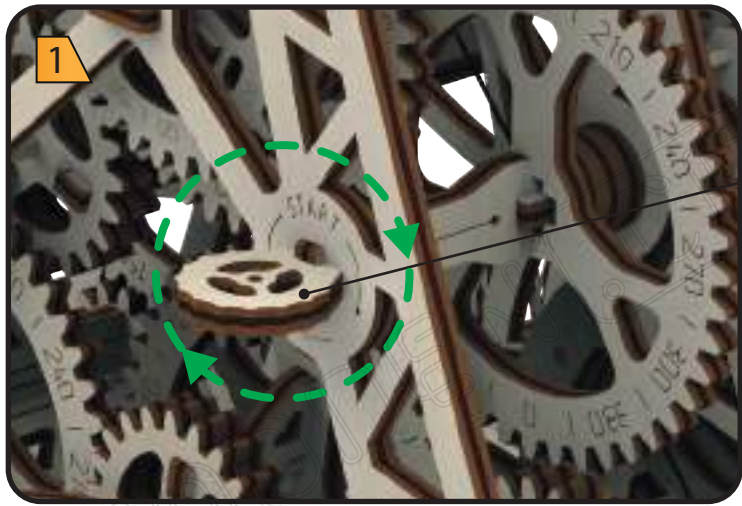

7x180°

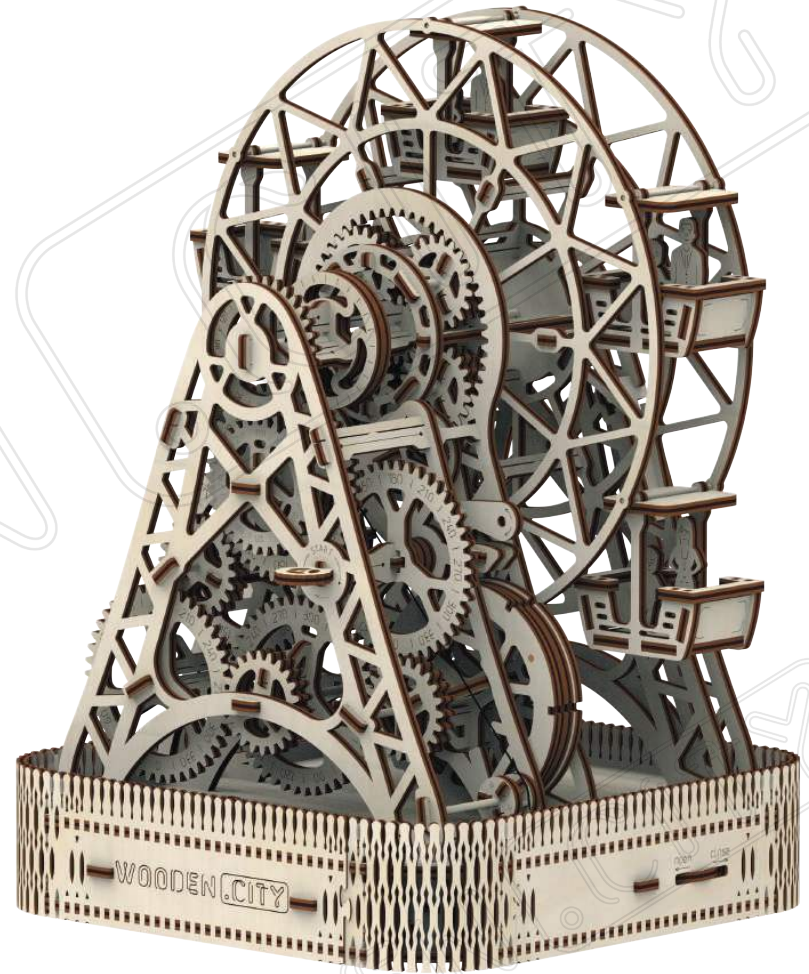
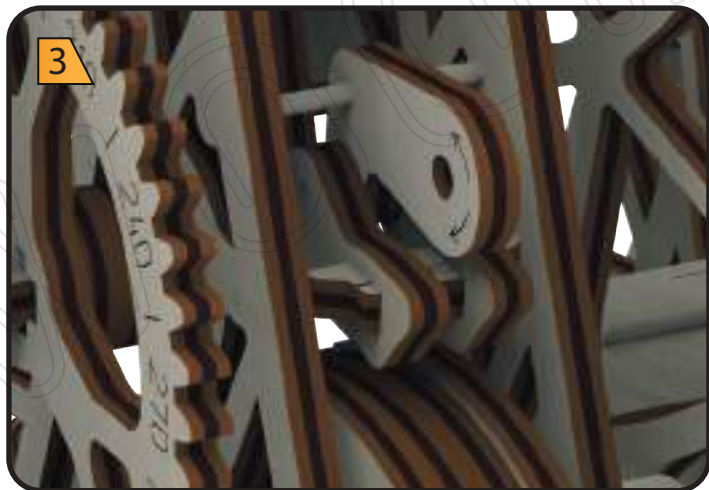
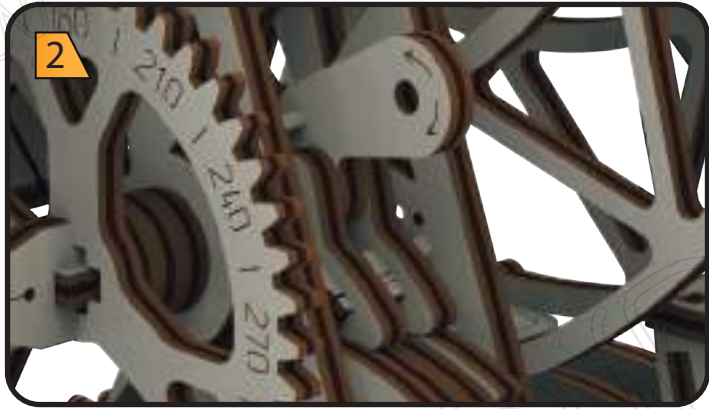

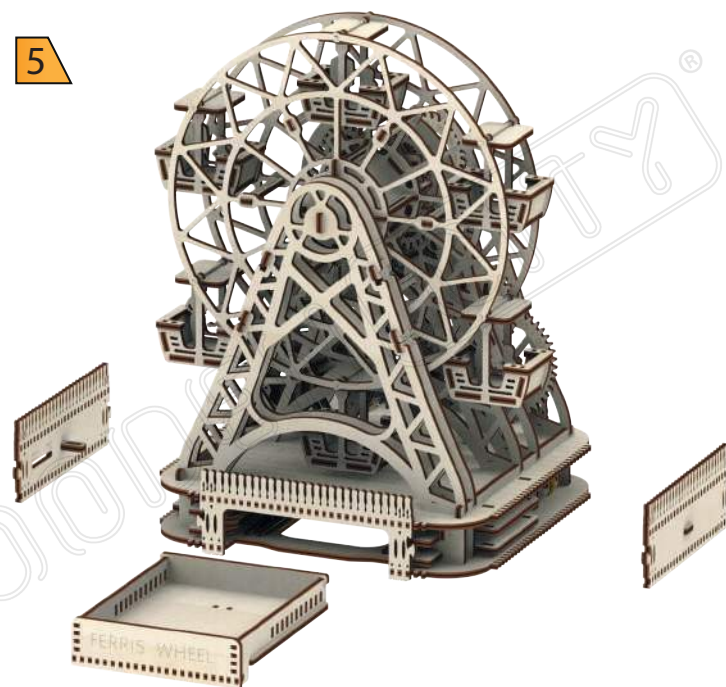
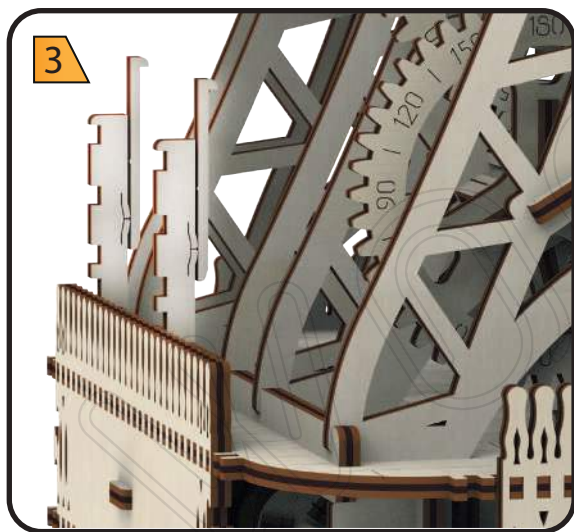
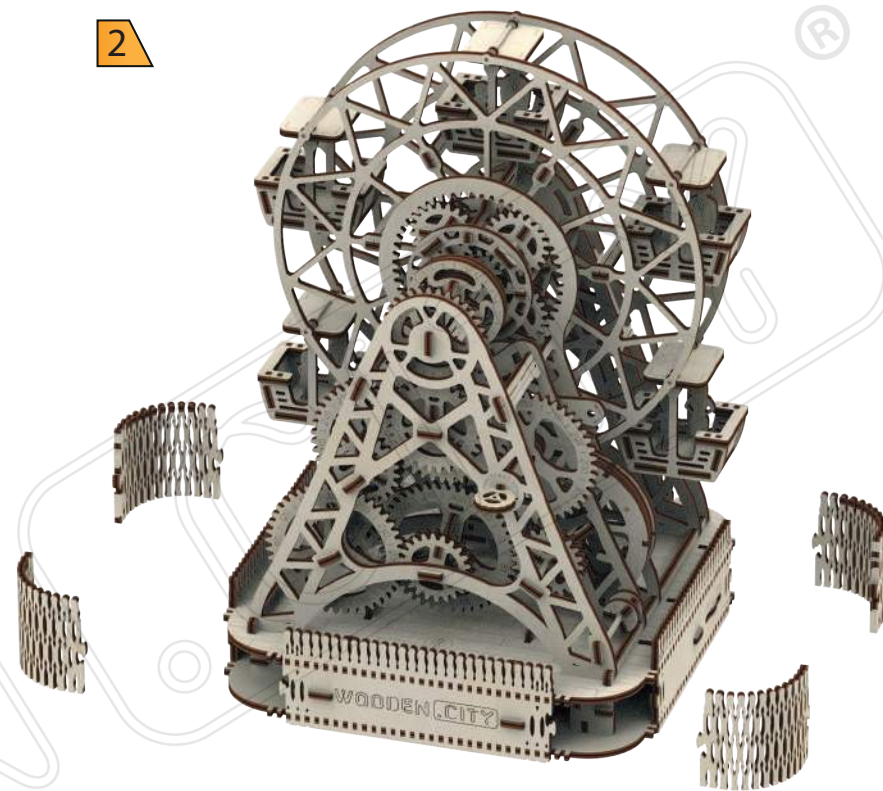

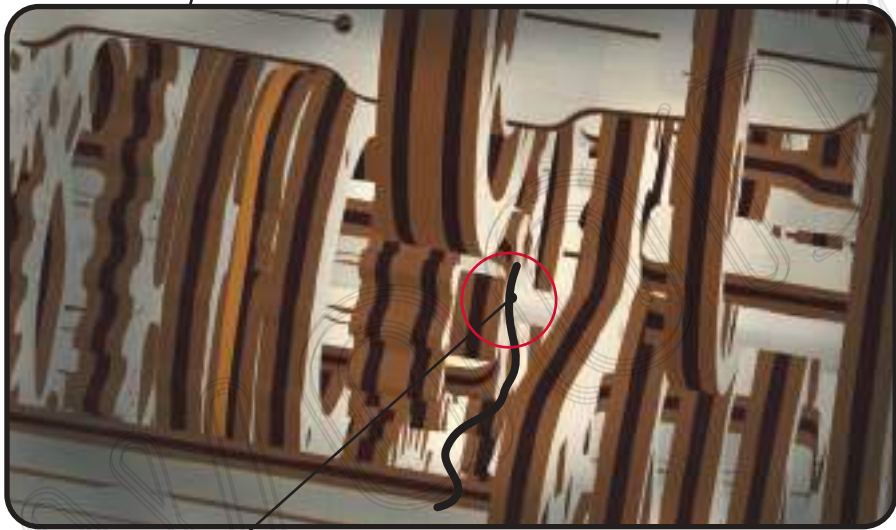
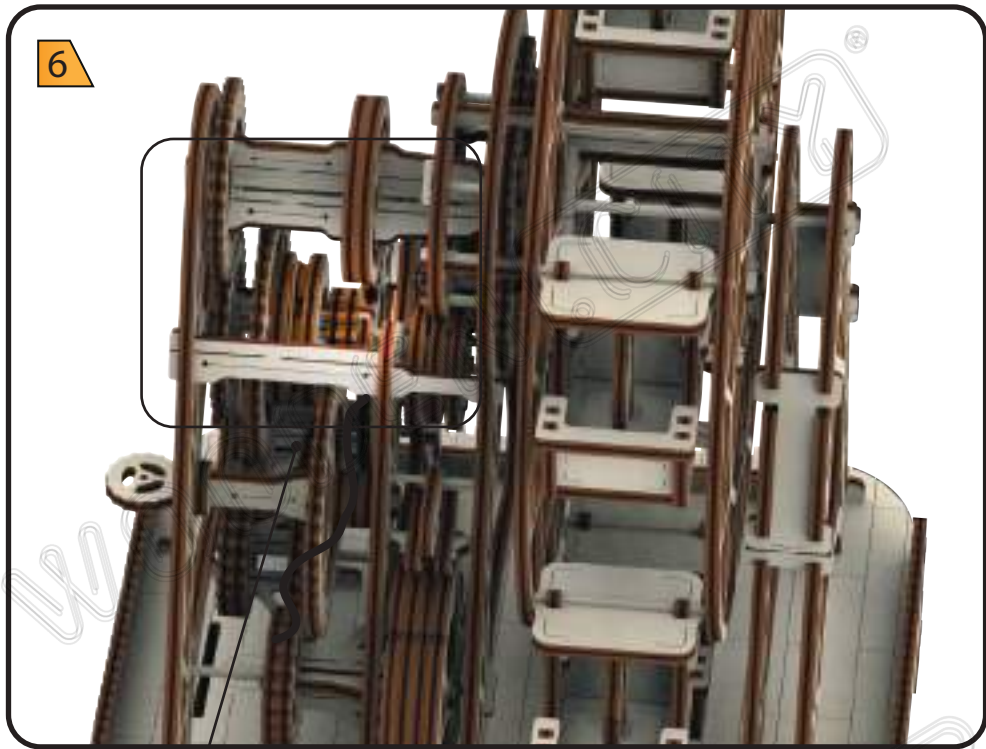

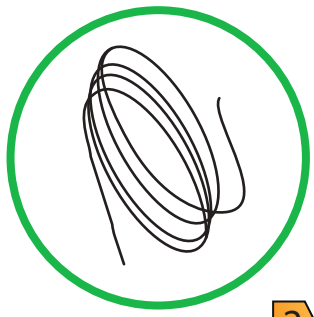

1



2

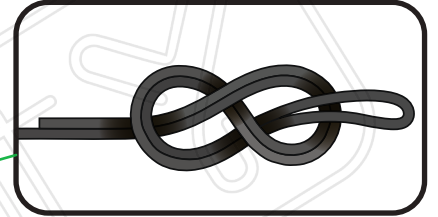
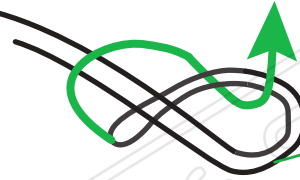
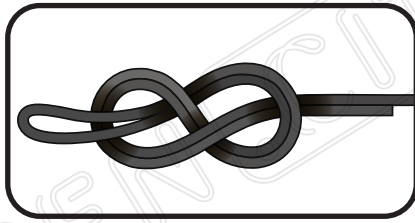

3



4



5

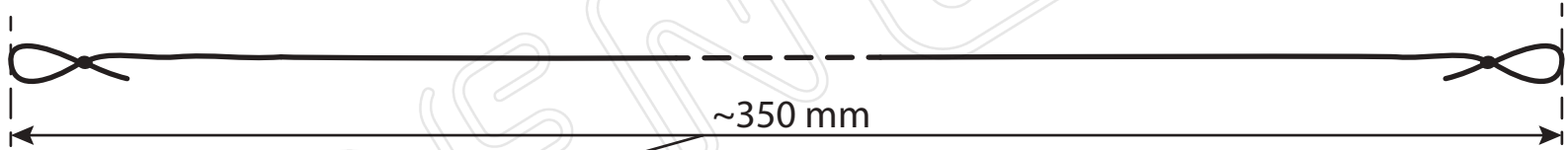

6

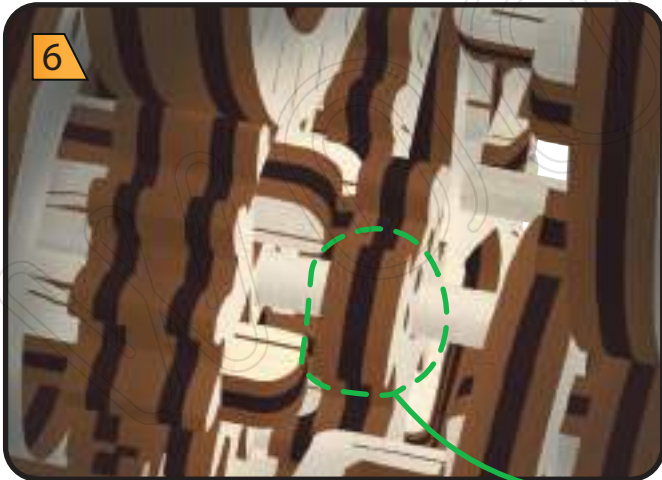

7

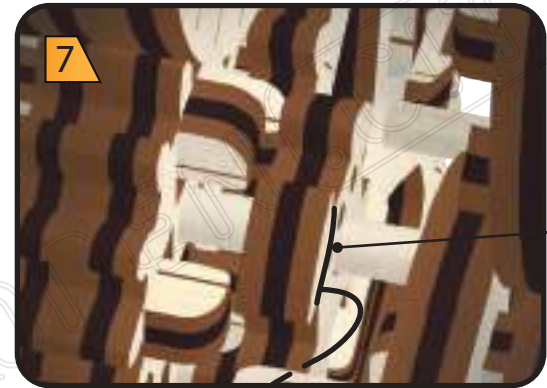

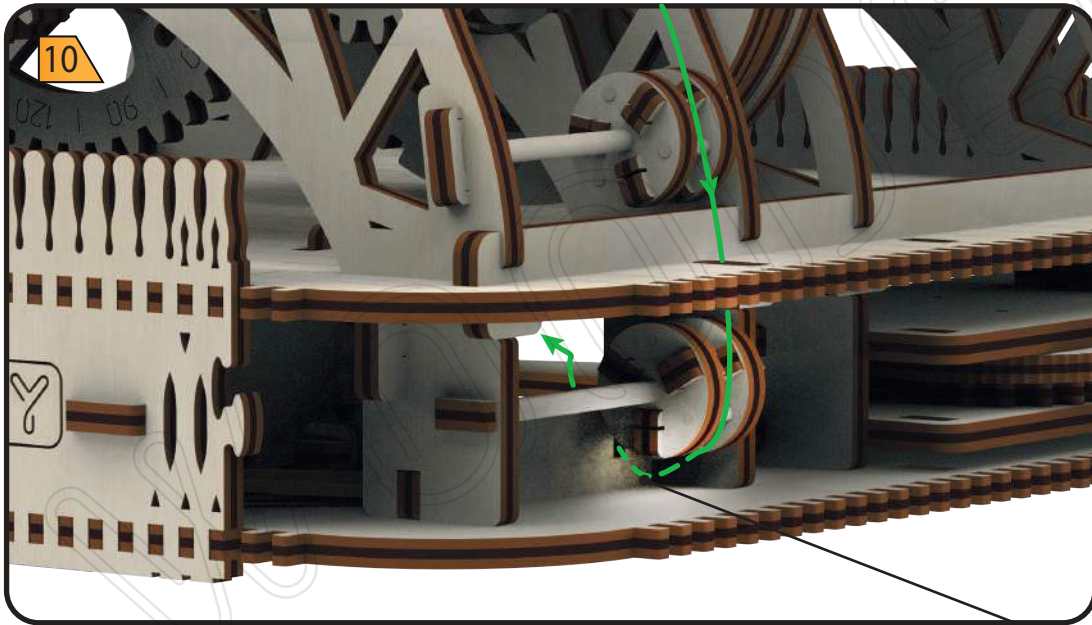
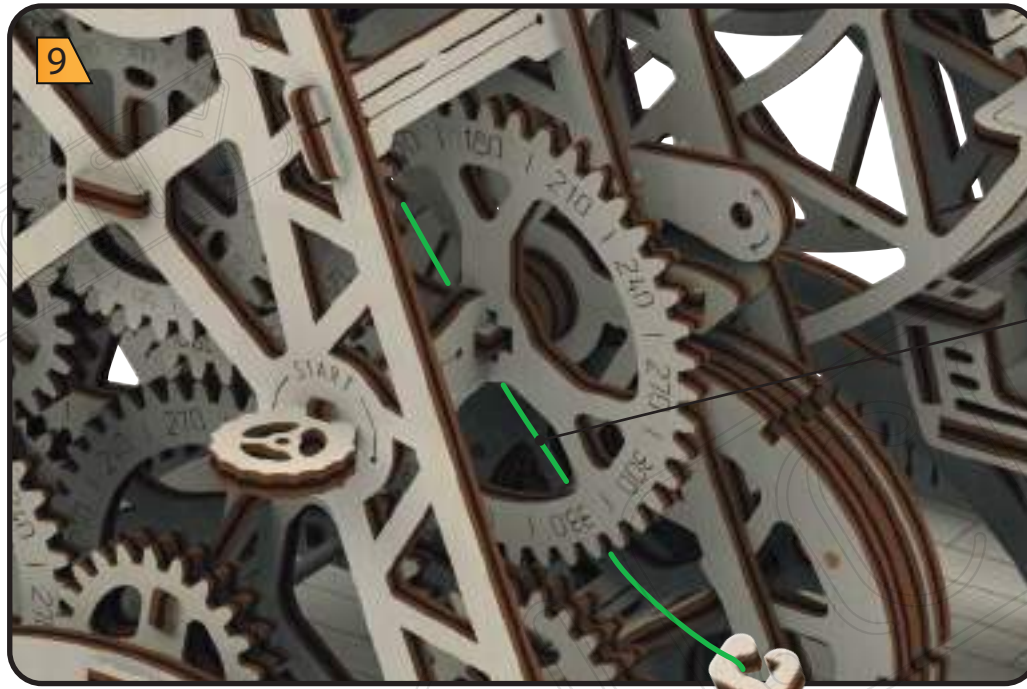

11

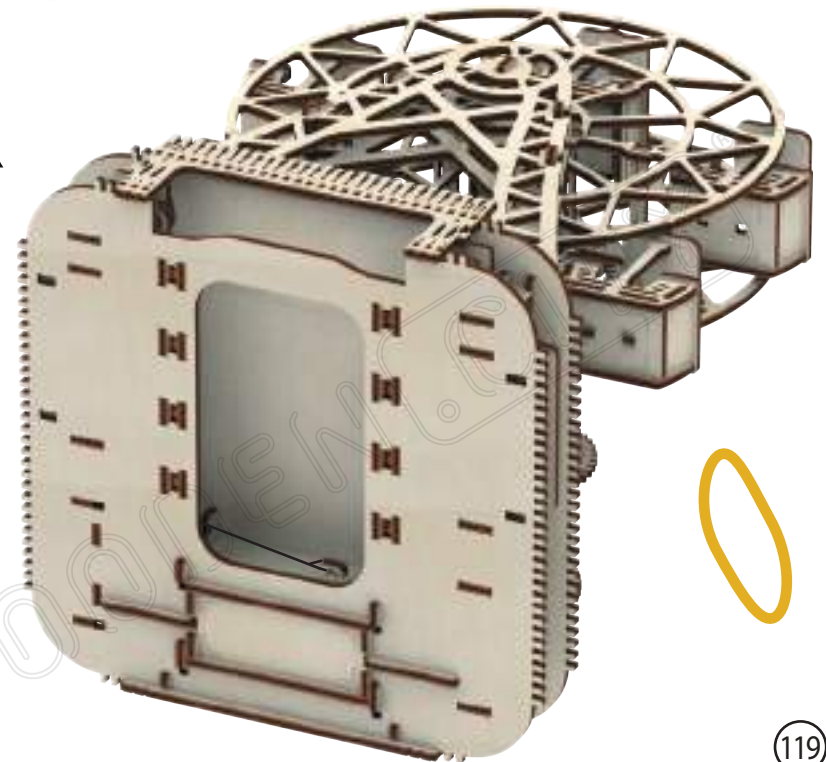

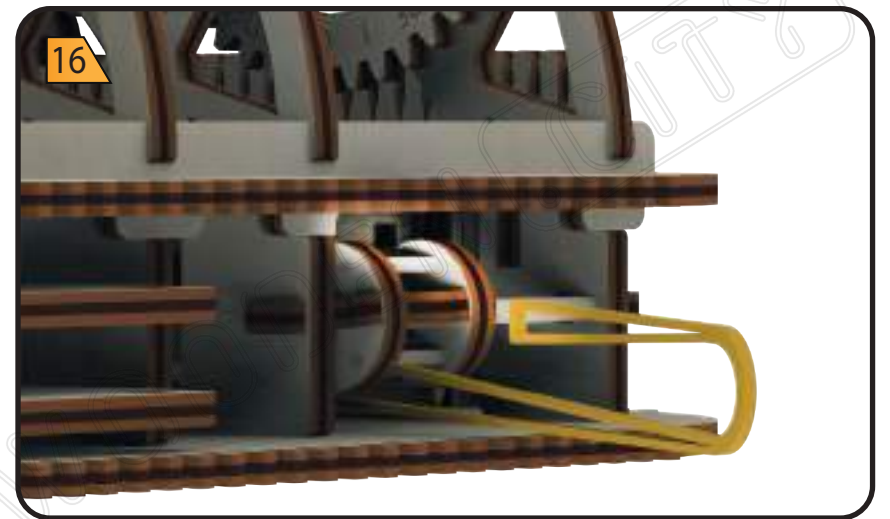
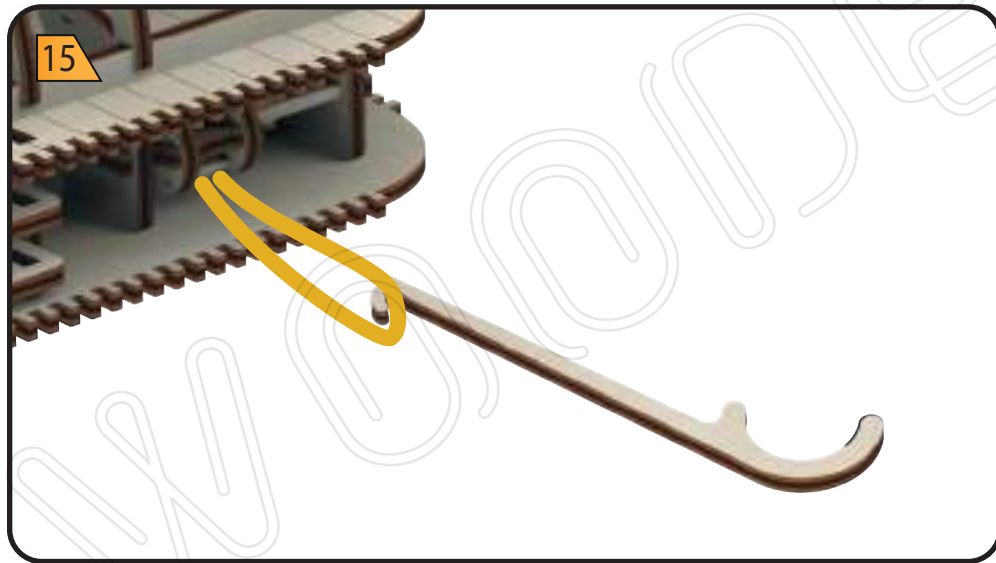
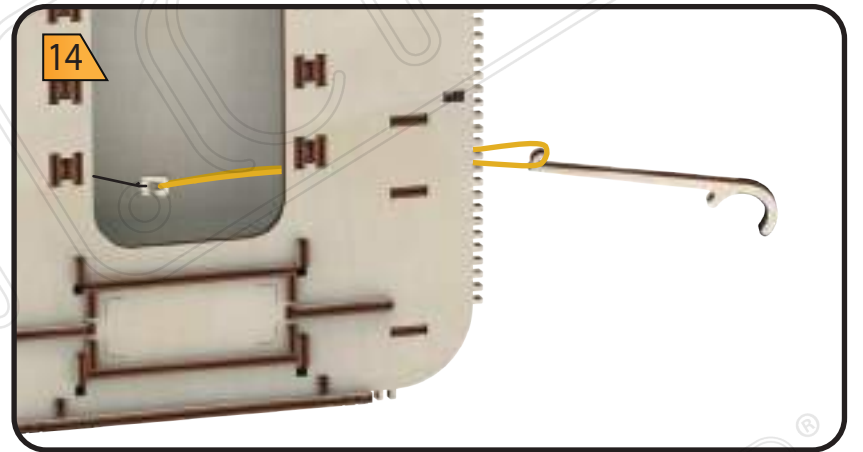
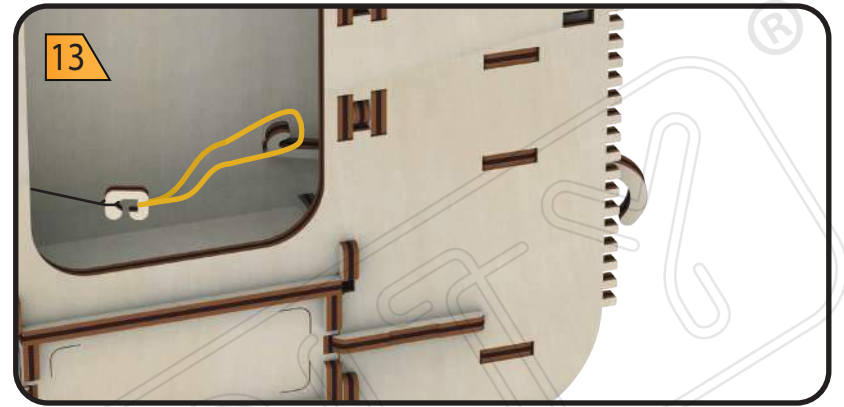
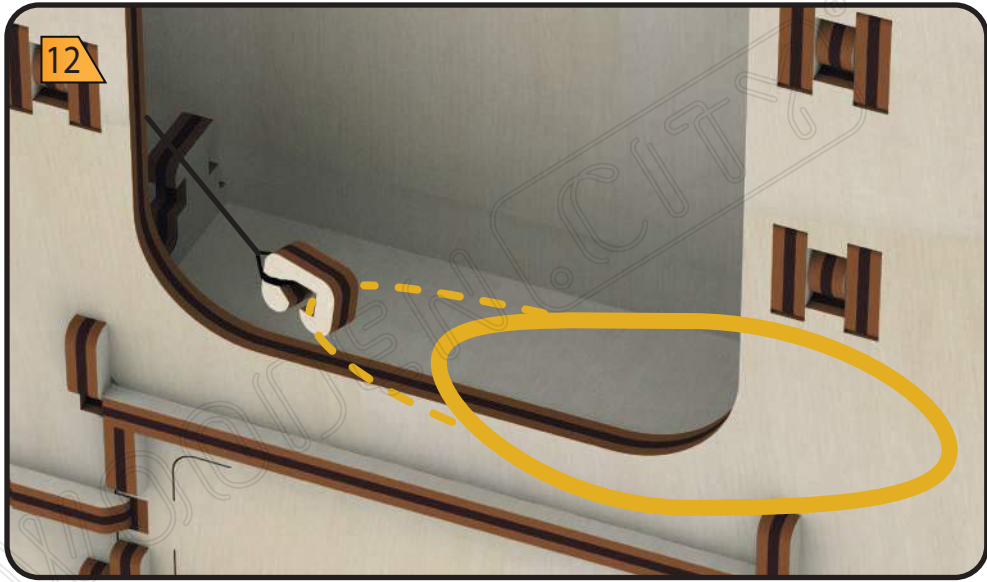

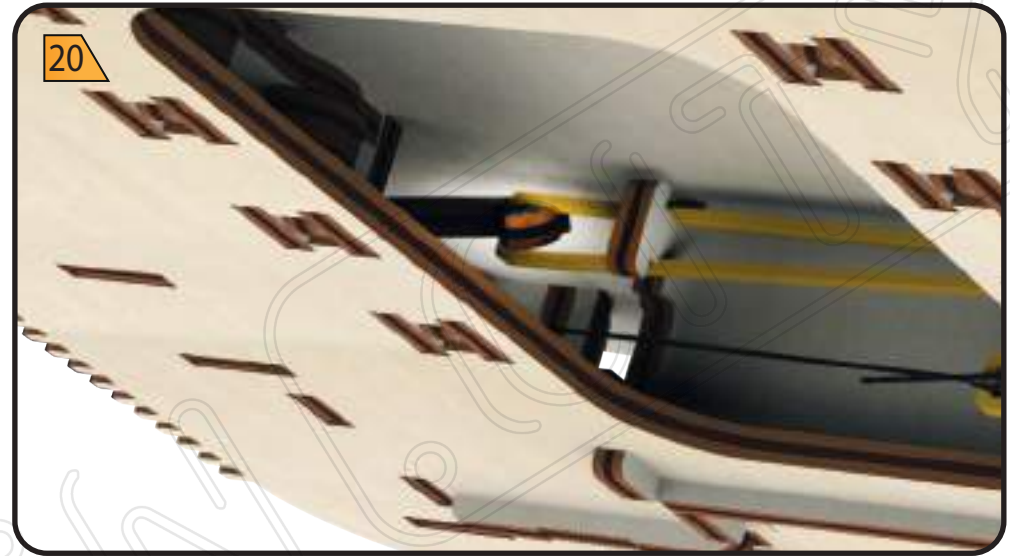
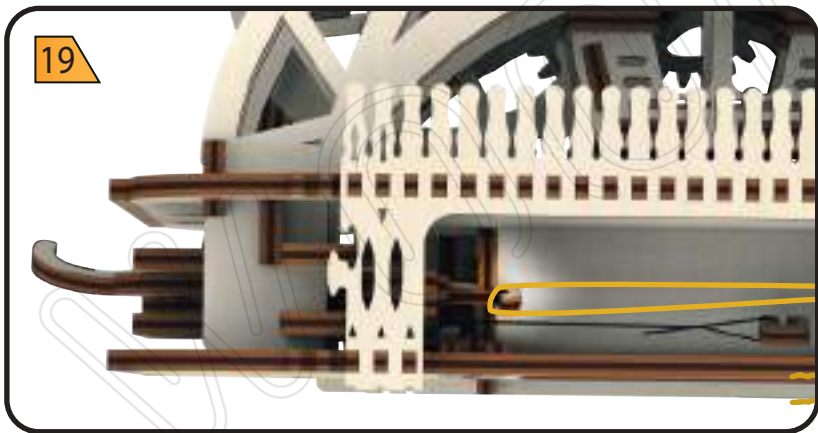
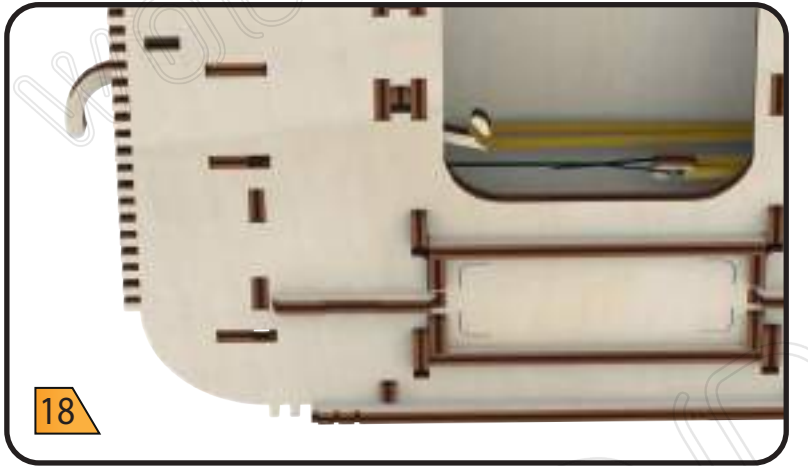
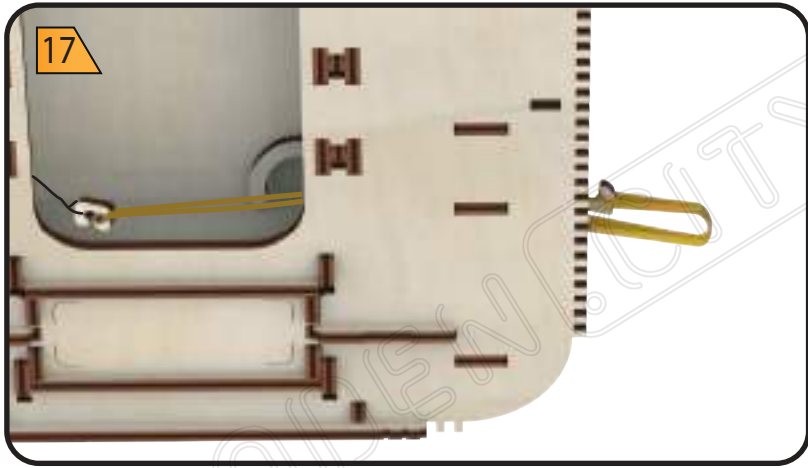

22

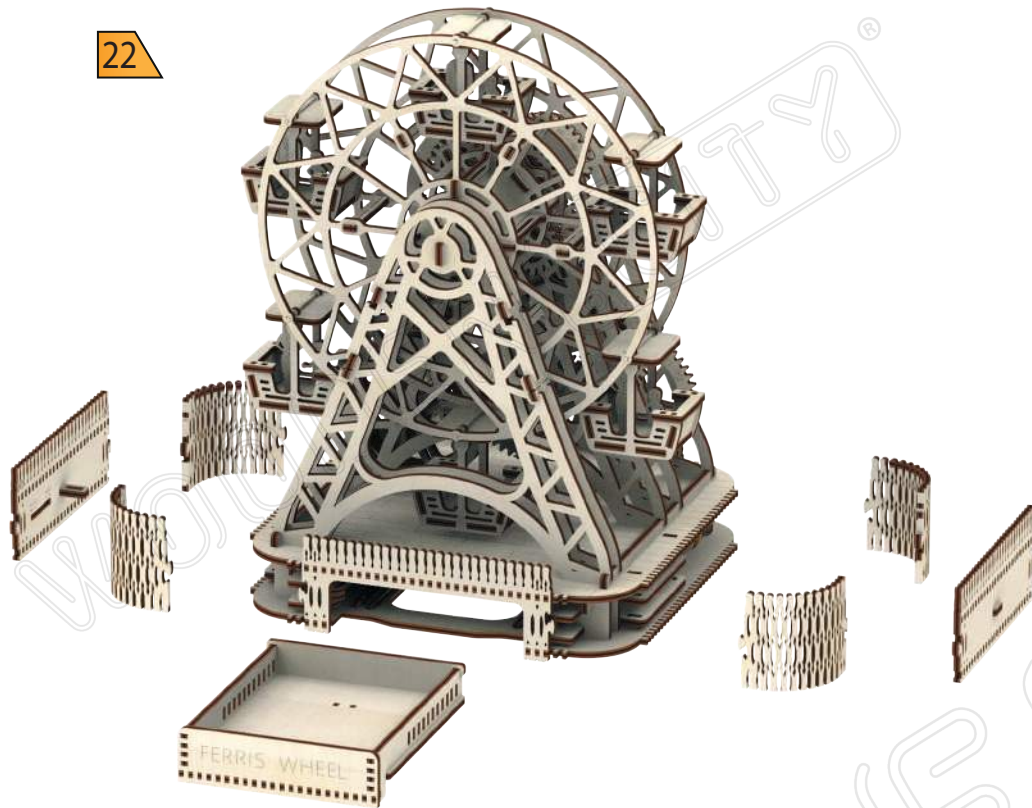

23

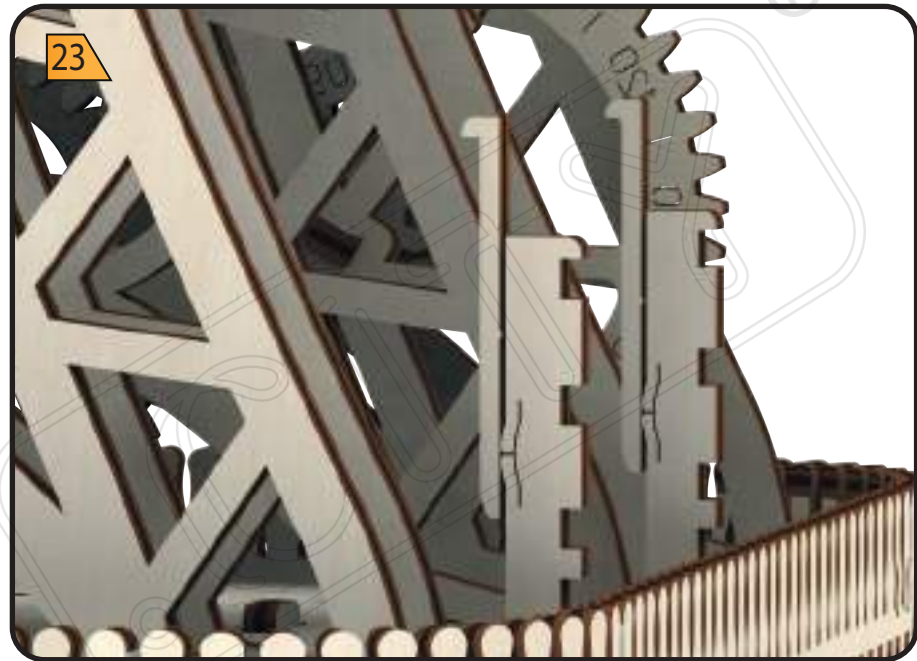

24

