

WOODEN CITY®



Mystery Box  
Assembly instruction

**EN**

Assembly instruction.

Package contains:

1. 151 parts on 5 ply sheets
2. 25 spare parts
3. Rubber bands
4. Axles
5. Ruler (for checking dimensions)

You will need: razor blade, scissors, sandpaper and wax candle. Very carefully push out the pieces from the front side of the board, taking care not to break them. If the piece does not come out, gently cut the notches with the razor blade. This model does not require glue or paint. To reduce friction, the gear face and the axle rotation areas should be waxed. Assemble in a well-lit area and follow the instructions carefully. You can also disassemble this model in reverse order.

**ES**

Instrucción de montaje.

El paquete contiene:

1. 151 partes fijadas en las 5 hojas de la madera contrachapada
2. 25 piezas de repuesto
3. Gomas elásticas
4. Ejes
5. Regla para comprobar las dimensiones

Para el montaje necesitará: cuchillo de papelería, tijeras, papel de lija y una vela. Con mucho cuidado exprimirá los detalles desde el anverso de la tabla, tratando de no romperlos. Si, el detalle no sale, corte suavemente los puentes con el cuchillo estacionario. Este modelo se monta sin pegamento y no requiere la pintura. Para evitar el agarrotamiento y para reducir la fricción, la cara del engranaje y las áreas de rotación del eje deben encerarse. Es recomendable montar el modelo con buena iluminación y seguir estrictamente las instrucciones. También puede desmontar este modelo en orden inverso.

**FR**

Instruction de montage.

Composant modèle:

1. 151 pièces sur 5 panneau
2. 25 pièces de rechange
3. Des élastiques
4. Axe
5. Il possède une règle pour vérifier les dimensions

Pour l'assemblage, vous auriez besoin: du couteau de papeterie, des ciseaux, du papier de verre et d'une bougie de cire. Il faut enlever les détails tout doucement du côté avant de la feuille, de soi, de façon qu'ils ne soient pas endommagés. Si l'article ne peut pas être retiré, coupez-le avec le couteau de papeterie. Le montage du modèle se fait sans colle et ne nécessite pas de peinture. Pour éviter les blocages et pour une meilleur glissement du mécanisme, il faut graisser les extrémités des engrenages et l'axe dans les zones de rotation avec la bougie de cire. Il est recommandé de monter le modèle ayant une bonne illumination et strictement selon les instructions. Vous pouvez également démonter ce modèle dans l'ordre inverse.

**PL**

Instrukcja składania

Zestaw zawiera:

1. 151 detali umieszczonych na 5 arkuszach sklejk
2. 25 części zapasowych
3. Gumki
4. Osie
5. Linijka do sprawdzania wymiarów

Do złożenia modelu niezbędne będą: nóż techniczny, nożyczki, papier ścierny oraz świeca woskowa. Detale wypycha się delikatnie od prawej strony arkusza uważając, aby ich nie uszkodzić. Jeżeli wystąpi trudność z wyciśnięciem pożądanego elementu, wówczas należy go delikatnie naciąć nożykiem z lewej strony arkusza. Powinno się wypychać z arkusza tylko te elementy nad którymi aktualnie się pracuje, w przeciwnym razie mogą się pogubić. Model należy składać przy dobrze doświetlonym stanowisku zgodnie z instrukcją. Model można rozłożyć w odwrotnej kolejności. Model składa się bez użycia kleju. W celu prawidłowego funkcjonowania mechanizmu, należy osie i koła zębate natrzeć świecą woskową.

**DE**

Aufbauanleitung.  
Im Set enthalten:

1. 151 Teile in 5 Platten
2. 25 Ersatzteile
3. Gummibänder
4. Achsen
5. Lineal zur Kontrolle

Fürs Zusammenbauen benötigen Sie: Messer, Schere, Schleifpapier und eine Kerze. Die Einzelteile werden von der Oberseite nach unten ausgedrückt. Wenn sich ein Teil nicht herausnehmen lässt, schneiden Sie die Haltestege mit dem Messer leicht ein Um ein Steckenbleiben vorzubeugen, schmieren Sie die Achsen und Zahnräder etwas mit dem Kerzenwachs ein. Dieses Modell ist ohne Kleber montiert und erfordert keine Lackierung. Sie beim Zusammenbau für eine gute Beleuchtung und setzen die Einzelteile strickt nach der Anleitung zusammen. Modell kann auch wieder auseinandergebaut werden.

**CN**

裝配說明。

每盒模型包括：

- 1、5片樺木板, 合共151件零件
- 2、25件備用零件
- 3、橡筋圈
- 4、轴
- 5、輔助測量尺

您會用到：美工刀、剪刀、砂紙、干蠟燭。請小心翼翼並從正對着板材的方向將零件推出，注意不要折斷。如果零件無法推出，可以用美工刀小心地輔助。此模型無需用到膠水和油漆。為防止交合和過大的摩擦，齒輪表面以及轉動軸的區域可以擦上干蠟。請在照明充足的情況下進行裝配並且積極遵循說明書。也可以通過逆向順序對模型進行拆解。

**RU**

Инструкция по сборке.  
Комплектация модели:

1. 151 деталь, расположенная на 5 листах фанеры
2. 25 запасных деталей
3. Резинки канцелярские
4. Оси
5. Линейка для проверки размеров

Для сборки Вам понадобится: канцелярский нож, ножницы, наждачная бумага и восковая свеча. Выдавливать детали нужно аккуратно с лицевой стороны листа от себя, чтобы их не повредить. Если деталь не вынимается, надрежьте перемычки канцелярским ножом. Модель собирается без клея и не требует покраски. Для предотвращения заклинивания и наилучшего скольжения механизма, необходимо торец шестерни и оси в местах вращения смазать восковой свечой. Собирать модель рекомендуется при хорошем освещении и строго по инструкции. Разбирать можно в обратной последовательности.

**IT**

Istruzioni di montaggio.

La scatola contiene:

1. 151 pezzi situati sui 5 fogli
2. 25 pezzi di ricambio
3. Elastici
4. Asse
5. La linea e/o dima per controllare le dimensioni

Il necessario per costruire: coltello di cancelleria, forbici, carta vetrata e cera di candela. Premere delicatamente sui pezzi pretagliati, dalla parte anteriore del foglio, per non rovinarli. Se il singolo pezzo non può essere rimosso, fate piccoli tagli con un taglierino da cancelleria. Il modello si monta senza colla e non ha bisogno di essere pitturato. Per evitare inceppamenti e migliorare lo scivolamento dei meccanismi, attrezzarsi di un prodotto lubrificante tipo cera di candela. Si consiglia di montare il modello con la luce adeguata e seguendo le istruzioni. Lo smontaggio dello stesso può avvenire con le dovute precauzioni. Smontare il modello possibile in ordine inverso.

EN Notations FR Désignation symbollique ES Notas  
 PL Oznaczenia umowne DE Symbolbezeichnung RU Условные обозначения  
 IT Simboli CN 符号示意



EN Approximate assembly time.  
 FR Temps d'assemblage estimé.  
 ES Tiempo estimado de construcción.  
 PL Przybliżony czas składnia.  
 DE Aufbauzeit.  
 RU Примерное время сборки.  
 IT Tempo di costruzione stimato.  
 CN 预估组装时间



EN Check orientation of each piece before connecting.  
 FR Vérifiez l'emplacement des éléments.  
 ES Comprobar la posición de los elementos.  
 PL Uwaga! sprawdź rozmieszczenie elementów.  
 DE Prüfen Sie die Positionen der Elemente.  
 RU Проверьте расположение элементов.  
 IT Controllare le posizioni degli elementi.  
 CN 检查零件位置



EN Check the measurements with the ruler.  
 FR Vérifiez les dimensions.  
 ES Comprobar los tamaños.  
 PL Sprawdź rozmiar.  
 DE Prüfen Sie die Abmessungen.  
 RU Проверьте размеры.  
 IT Controllare le dimensioni.  
 CN 检查零件尺寸



EN Press each piece all the way up to the stop.  
 FR Appuyez au maximum.  
 ES Presione hasta el tope.  
 PL Wciśnij do oporu.  
 DE Bis zum Anschlag zusammendrücken.  
 RU Прижмите до упора.  
 IT Premere per interrompere.  
 CN 向上压紧直至到位



EN Use wax.  
 FR Lubrifiez les pièces avec la bougie.  
 ES Cera los detalles.  
 PL Natrzyj element świecą woskową.  
 DE Mit Kerzenwachs einschmieren.  
 RU Смажьте детали свечой.  
 IT Candela per Lubrificare le parti.  
 CN 给零件上干蜡



EN Remember spare pieces are included.  
 FR Pièces de rechange.  
 ES Detalles de repuesto.  
 PL Części zamienne.  
 DE Ersatzteile.  
 RU Запасные детали.  
 IT Pezzi di ricambio.  
 CN 备用零件



EN Cut off with a knife.  
 FR Coupez avec le couteau.  
 ES Cortar con el cuchillo.  
 PL Odetnij nożem.  
 DE Abschneiden.  
 RU Отрежьте ножом.  
 IT Tagliare.  
 CN 用美工刀切断



EN Carefully move apart.  
 FR Faites séparer délicatement.  
 ES Separar cuidadosamente.  
 PL Delikatnie rozsunąć detale.  
 DE Vorsichtig auseinanderschieben.  
 RU Аккуратно раздвиньте.  
 IT Far scorrere delicatamente.  
 CN 分离时多加小心



EN Use sandpaper or razor blade to smooth notches on each piece.  
 FR Les bavures après les coupures doivent être poncées légèrement avec du papier de verre fin ou coupées soigneusement avec un couteau de papeterie.  
 ES Las rebabas en el puente deben ser amoladas suavemente con el papel esmeril o cortadas cuidadosamente con el cuchillo estacionario.  
 PL Uwaga: pozostałości po zaczepach technicznych na detalach można usunąć drobnoziarnistym papierem ściernym lub nożem technicznym.  
 DE Eventuell verbleibende Haltereste mit Messer oder Schleifpapier entfernen. Das Modell wird ohne Kleber zusammengesetzt.  
 RU Заусенцы от перемычек следует отшлифовать легкими движениями мелкой наждачной бумагой или аккуратно срезать канцелярским ножом.  
 IT Le barbe dei ponticelli devono essere levigate leggermente con la sottile carta vetrata o tagliati con cautela con coltello di cancelleria.  
 CN 推出后的零件边缘可能会有毛刺，请用砂纸去除，也可以用美工刀小心切除。



EN The part numbers that are included in this node.  
 FR Les références sont incluses dans cette unité.  
 ES Números de piezas que forman parte de la junta.  
 PL Numery części, które wchodzą do składu danego węzła.  
 DE Die Nummern der Elemente, die zu diesem Teil des Modells gehören.  
 RU Номера деталей которые входят в этот узел.  
 IT Numero di pezzi per questo nodo.  
 CN 此信息已包括所需要组件编号

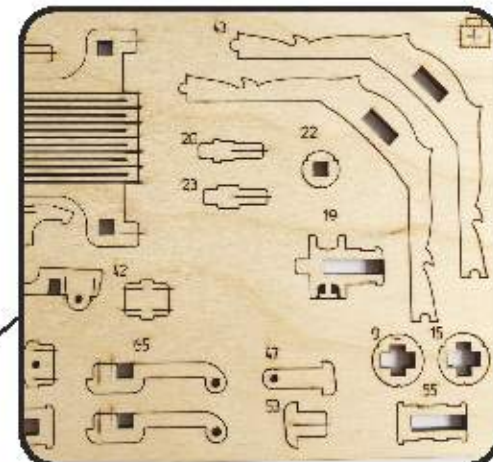
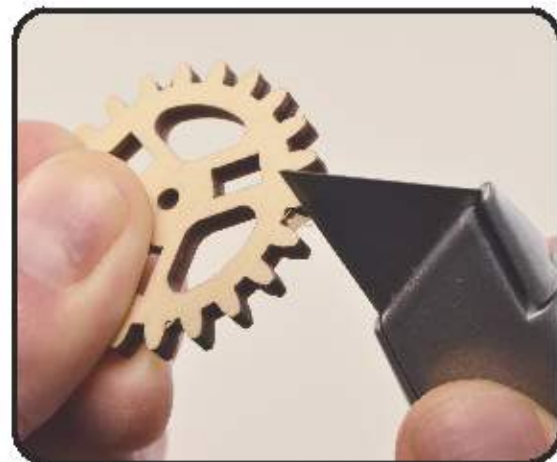
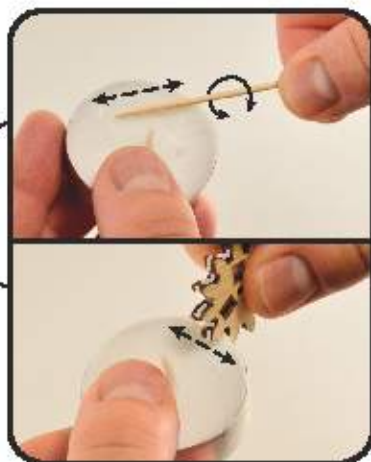

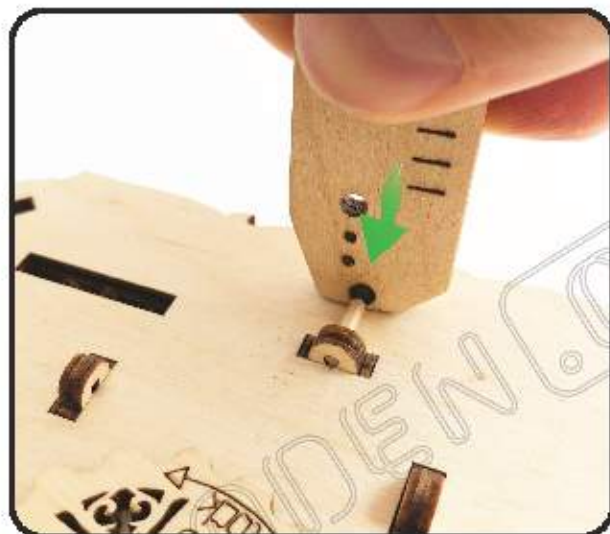

**EN** The ruler is used for size check. **FR** La règle pour vérifier les dimensions. **ES** La escala para la verificación de tamaño. **PL** Linijka do sprawdzenia wymiarów. **DE** Lineal um diverse Abmessungen zu prüfen. **RU** Линейка для проверки размеров. **IT** La linea per controllare le dimensioni. **CN** 辅助测量尺

**EN** These holes help to push thin axles through several of the pieces. **FR** Les ouvertures indiquées vous aideront à pousser l'axe fin à travers quelques détails. **ES** Estos agujeros ayudan a empujar el eje delgado a través de varios detalles sobre ejes. **PL** Otwory w linijce mogą być pomocne przy przeciskaniu patyczków (osi) przez kilka elementów. **DE** Die angegebenen Öffnungen helfen Ihnen, eine dünne Achse durch mehrere Öffnungen zu schieben. **RU** Указанные отверстия помогут протолкнуть тонкую ось через несколько деталей. **IT** Questi piccoli fori aiuteranno a spingere ed inserire l'asse attraverso le piccole parti. **CN** 小孔是用于帮助细轴穿过不同零件而设计的。



**EN** The yellow rubber band is for the rotation of the model mechanism. Install it as shown in the picture. **FR** L'élastique jaune est conçu pour faire tourner le mécanisme du modèle. Installez-le comme est indiqué sur le dessin. **ES** El caucho amarillo es para la rotación del mecanismo del modelo. Instálolo como se muestra en la imagen. **PL** Żółta gumka przeznaczona jest do napędu mechanizmu modelu. Zamontować ją należy zgodnie z instrukcją. **DE** Gelbes Gummiband dient dazu, den Mechanismus zu drehen. **RU** Желтая резинка предназначена для вращения механизма модели. Установите её как показано на рисунке. **IT** Elastico giallo serve per il movimento del meccanismo del modello. Installare come mostrato nel disegno. **CN** 黄色皮筋用于模型机构的旋转。请按图示进行安装。

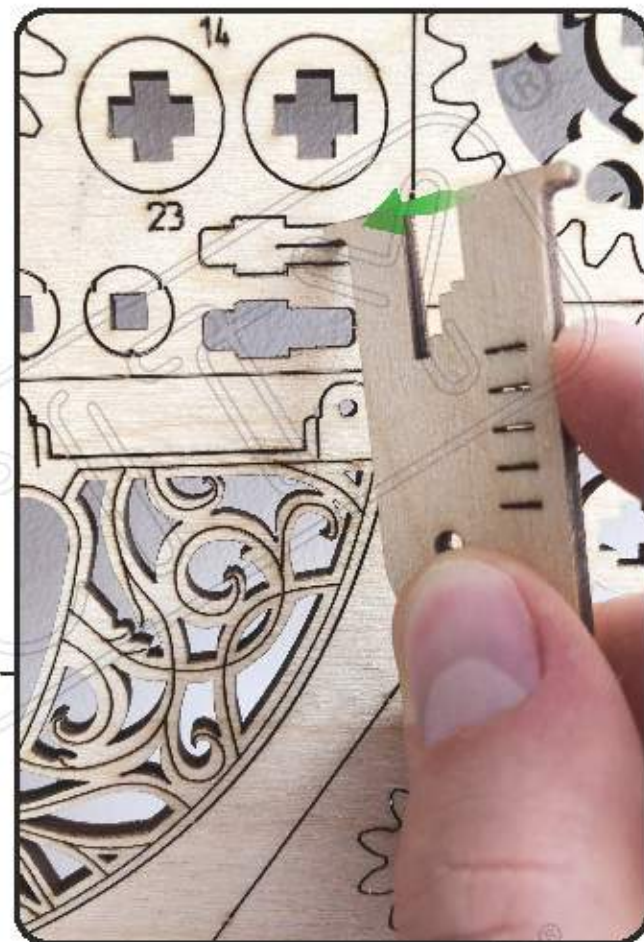

**EN** This tool is for pushing the small pieces out of the board. Also may be used for disassembly. **FR** La proéminence est conçue pour aider à presser et enlever les petites pièces de la feuille. On peut l'utiliser aussi pour pousser les petites pièces lors du démontage du modèle. **ES** La repisa es para apretar los pequeños detalles fuera del tablero. Además, también puede empujar los pequeños detalles en el proceso de desmontaje. **PL** Występ w linijce przeznaczony jest do wyciskania małych detali z arkusza sklejk. Można go wykorzystać również przy rozkładaniu modelu. **DE** Der Vorsprung dient dazu, kleine Teile aus den Platten zu drücken. Er kann auch zum ausdrücken kleiner Teile beim Auseinanderbauen des Modells benutzt werden. **RU** Выступ предназначен для выталкивания из листа мелких деталей. Также им можно выталкивать мелкие детали при разборке модели. **IT** Le proiezioni riportate sui fogli di istruzione sono utili anche nella fase di smontaggio per estrarre i pezzi. **CN** 推件器是用于将小零件从板材上推出。您可以遵照2张示意图中的拆解步骤将小零件推出。

EN Axles FR Axe ES Ejes PL Osie  
DE Achsen RU Оси IT Asse CN 轴

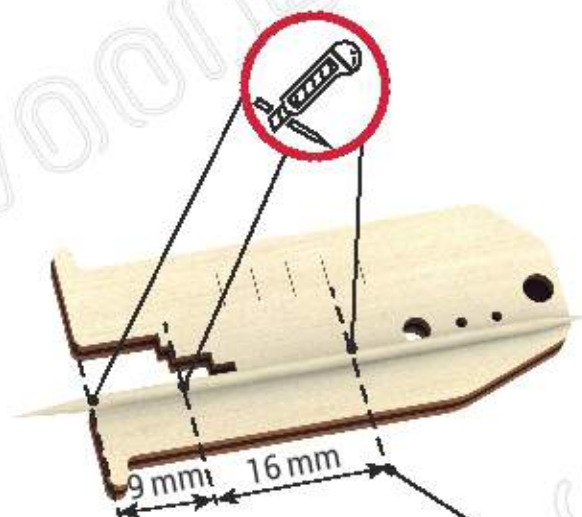

EN Check the measurements.  
FR Vérifiez les dimensions.  
ES Comprobar los tamaños.  
PL Sprawdzić rozmiar.  
DE Prüfen Sie die Abmessungen.  
RU Проверьте размеры.  
IT Controllare le dimensioni.  
CN 检查零件尺寸



0

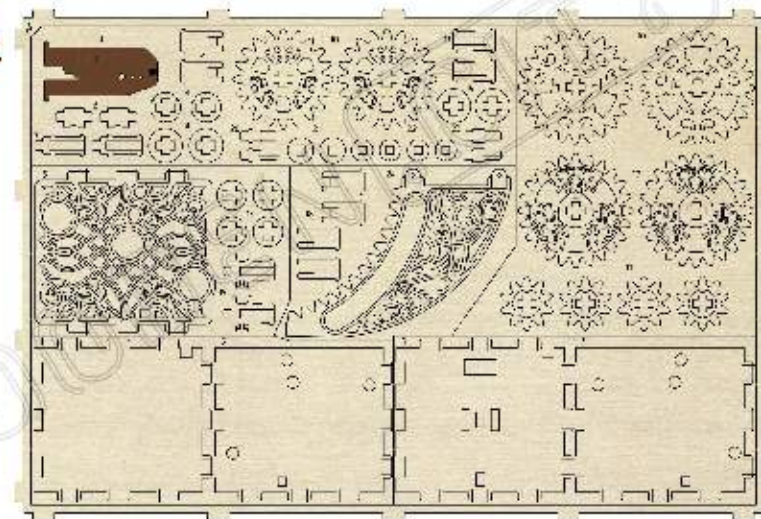

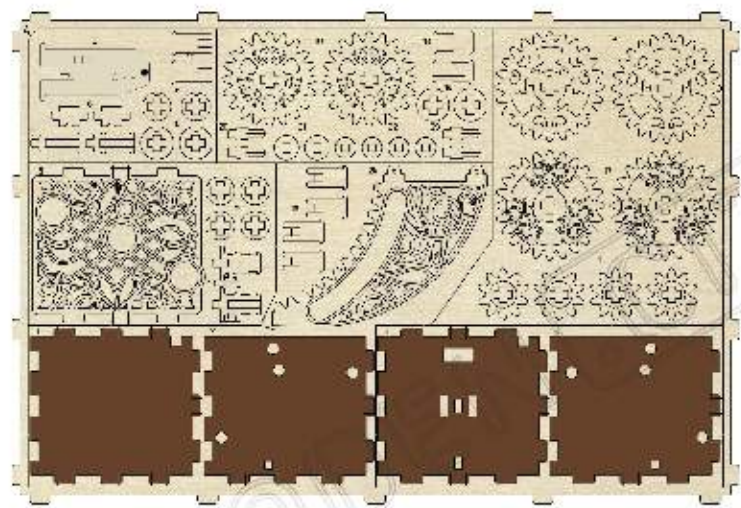

1

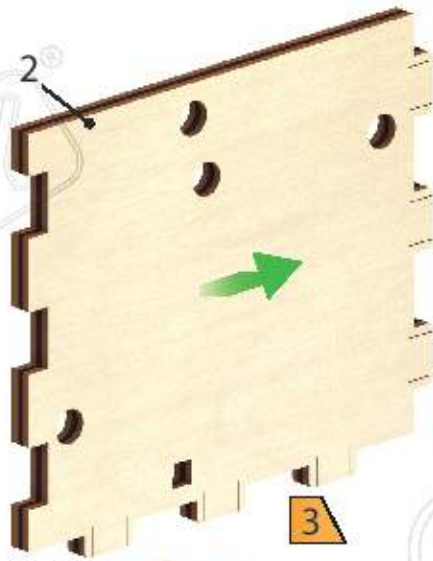

3

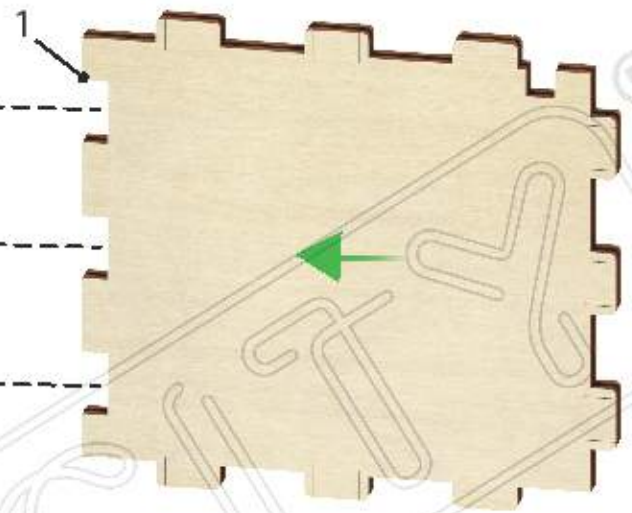

2

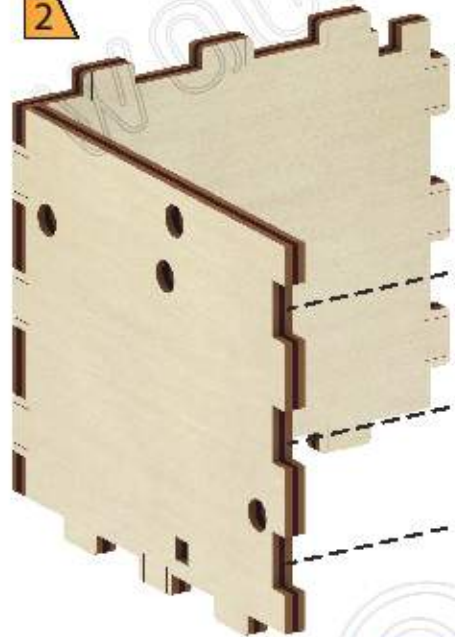

3

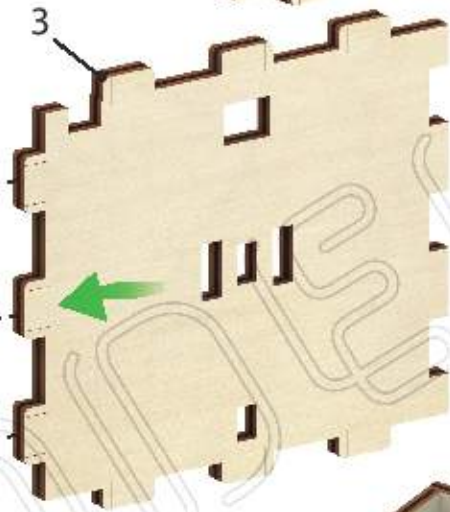

4

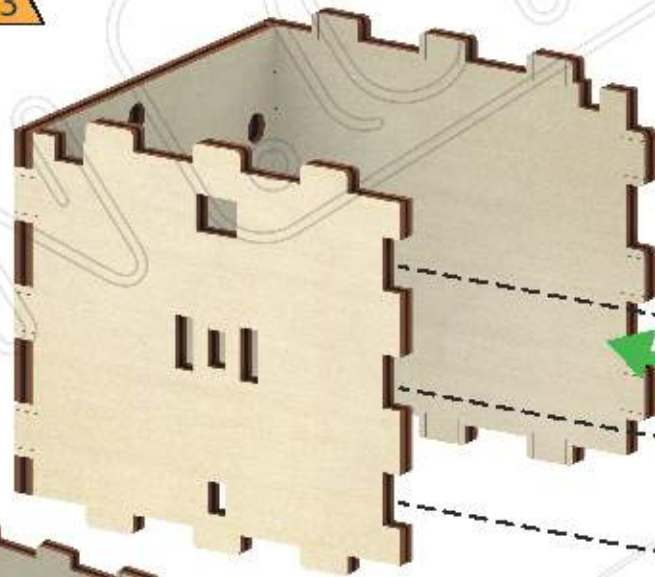

4



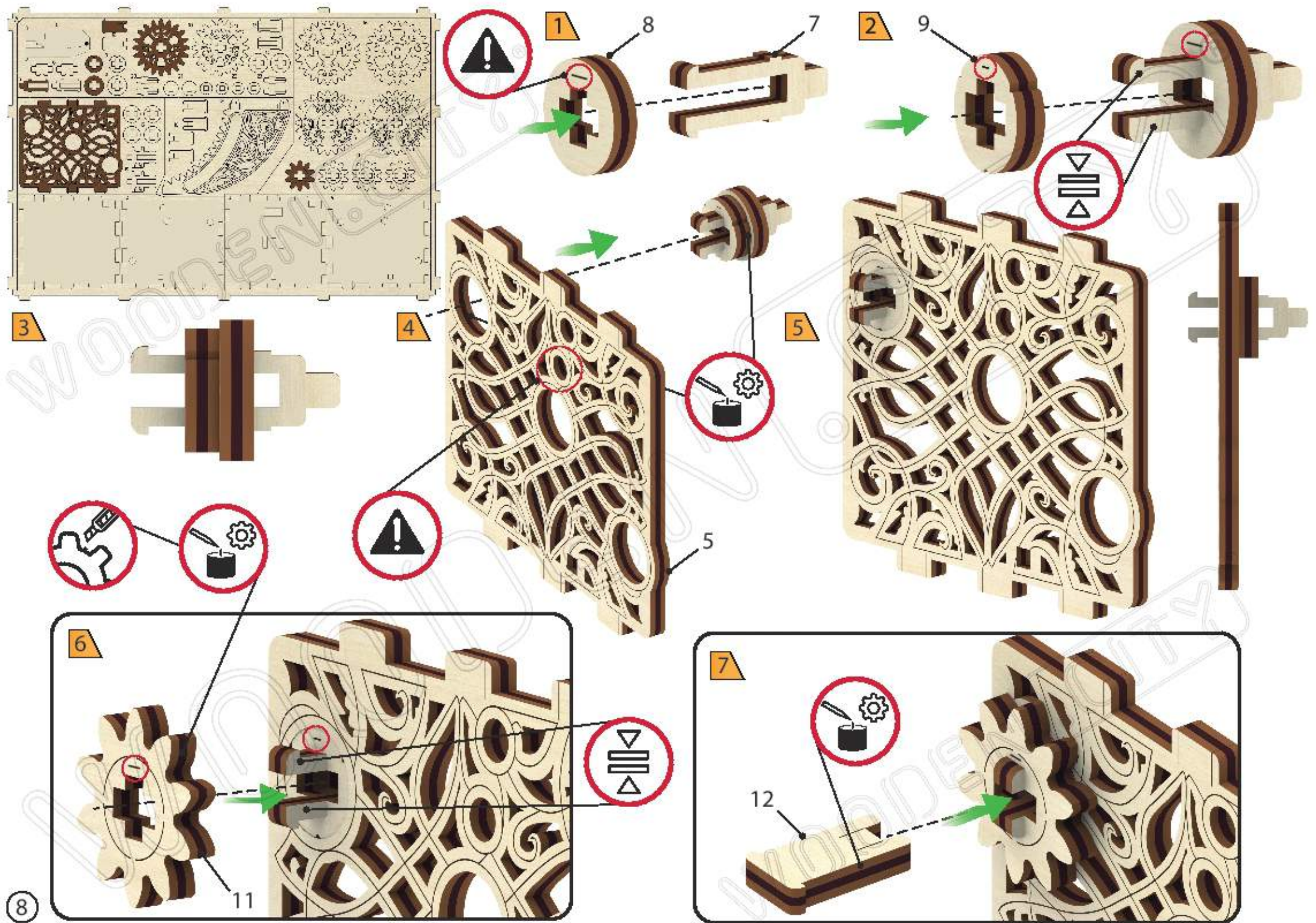



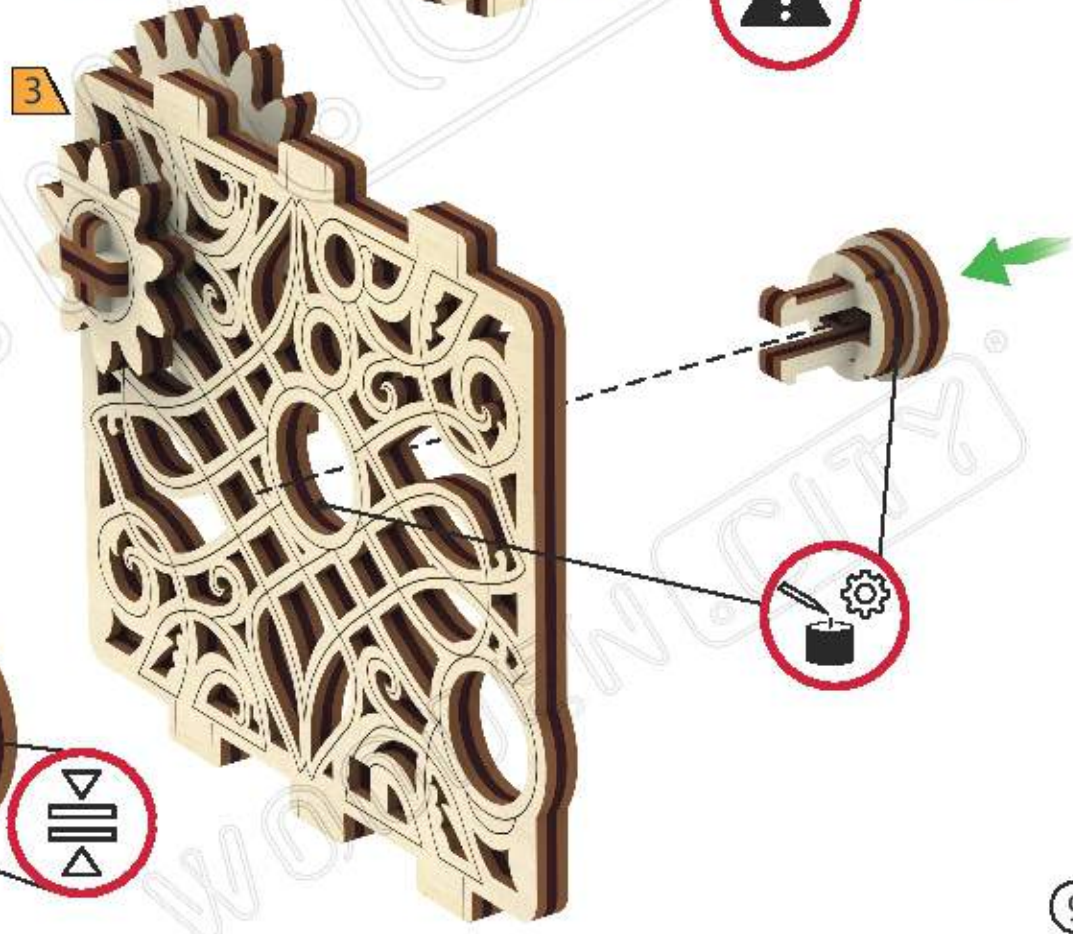
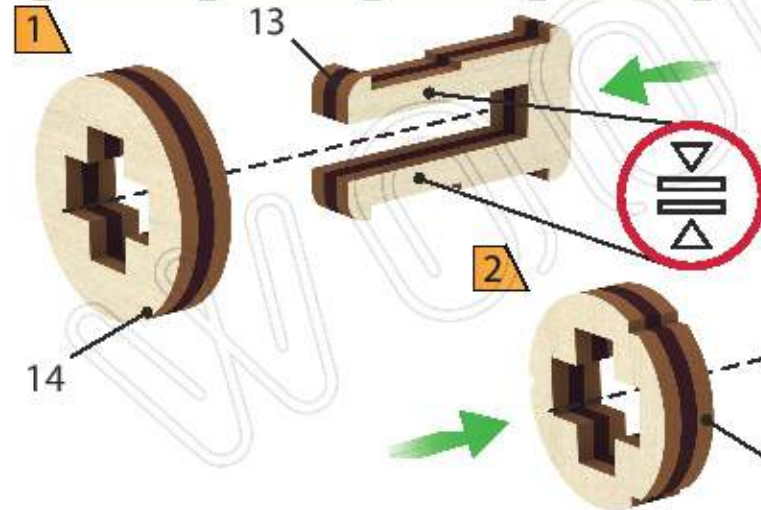
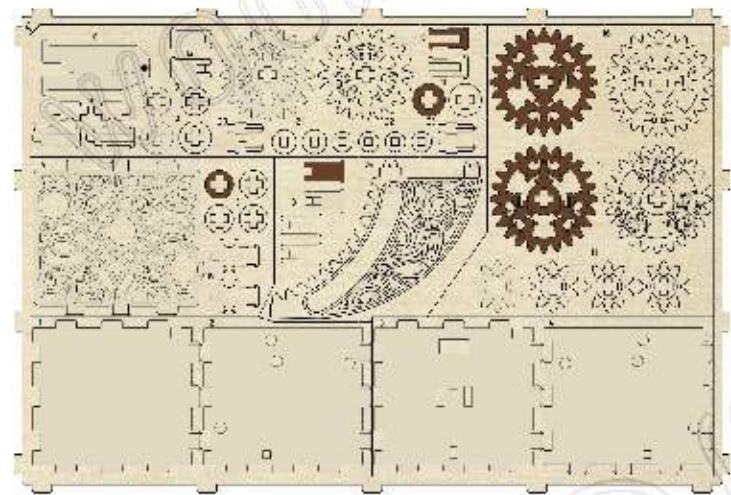
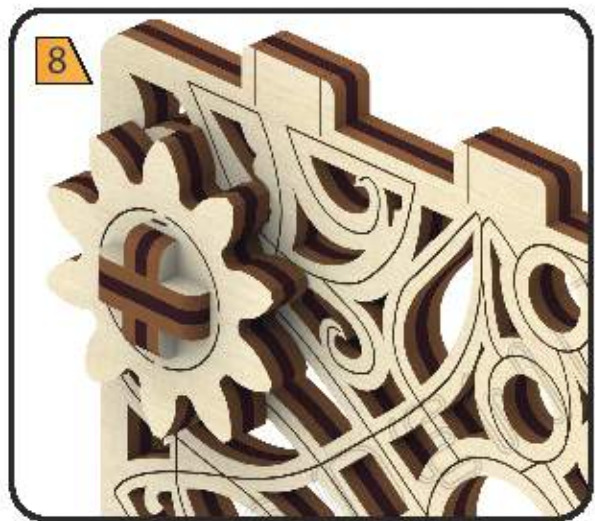

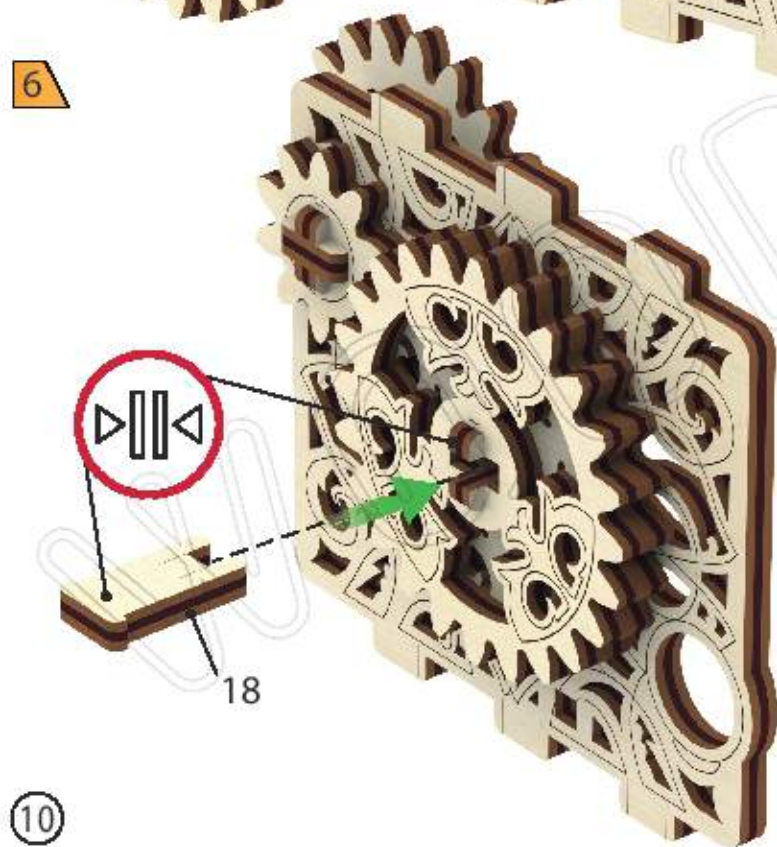
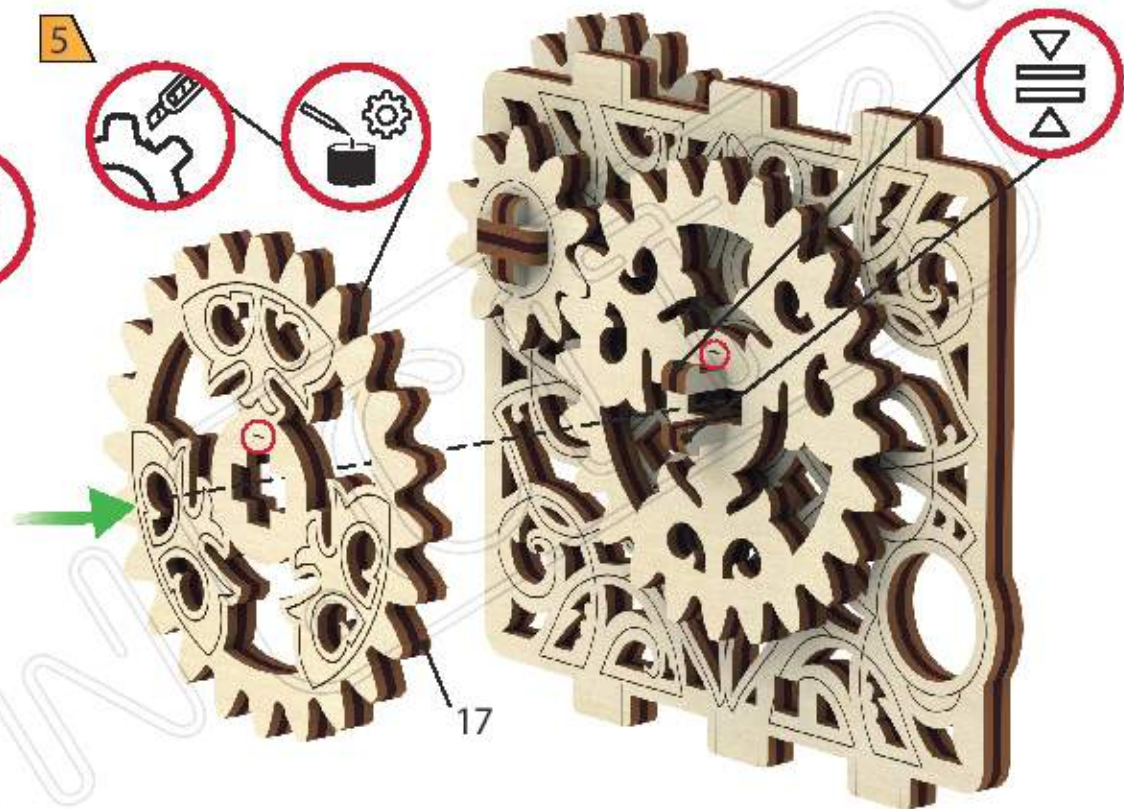

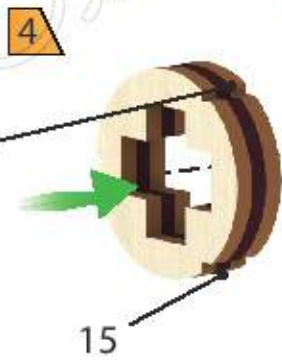
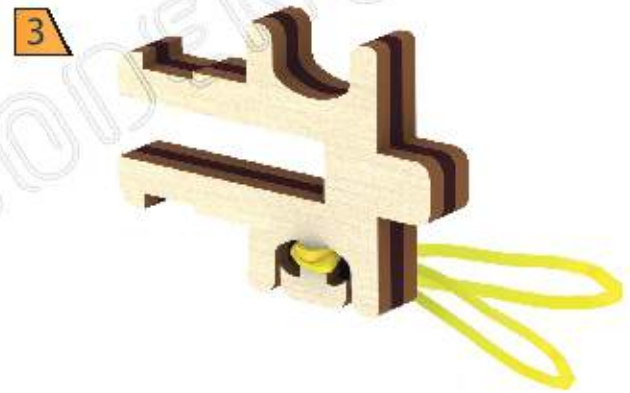
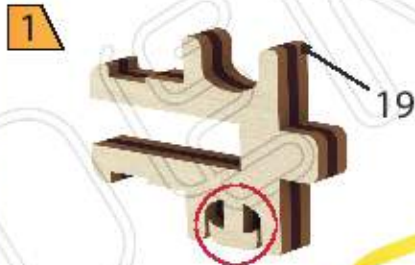
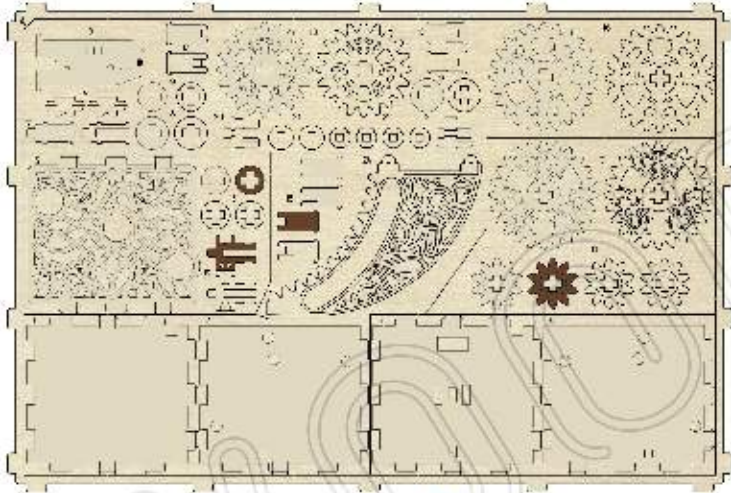
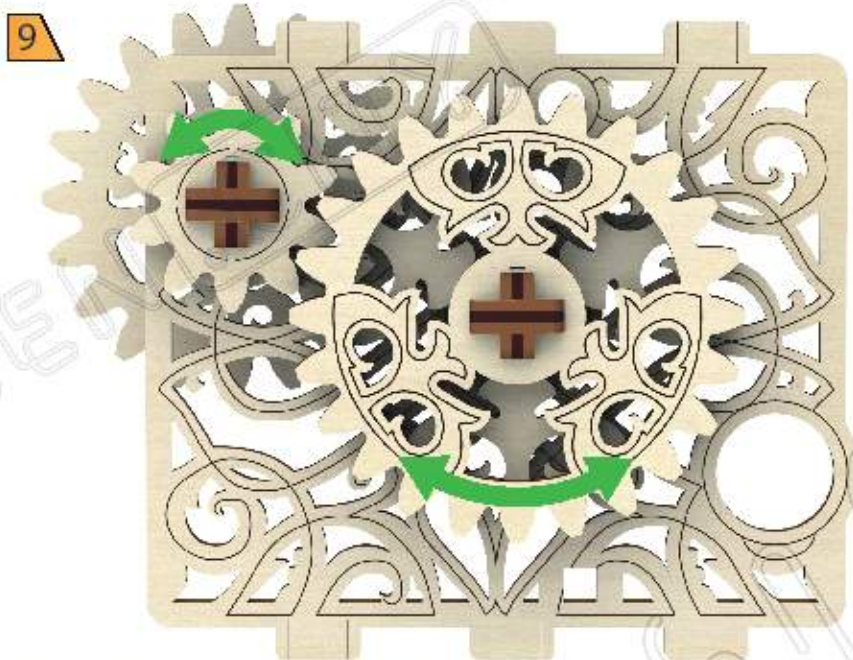

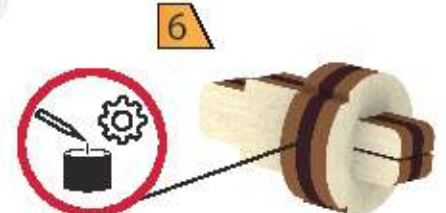
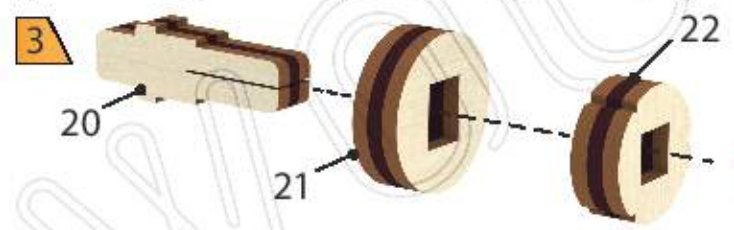
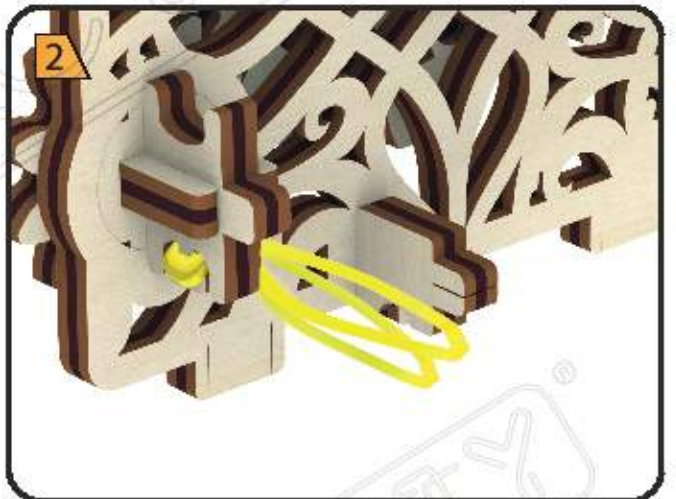
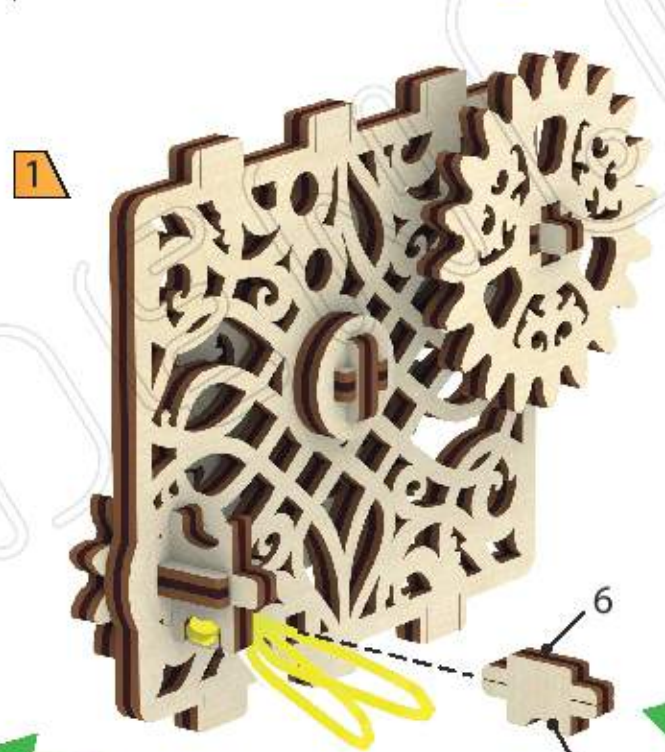
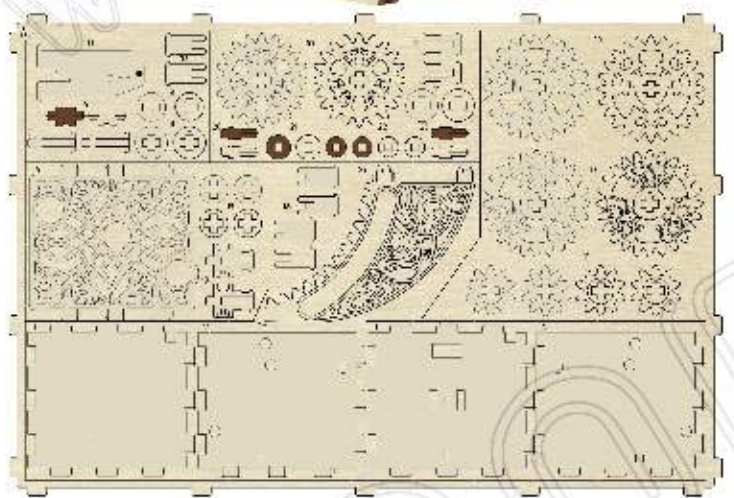
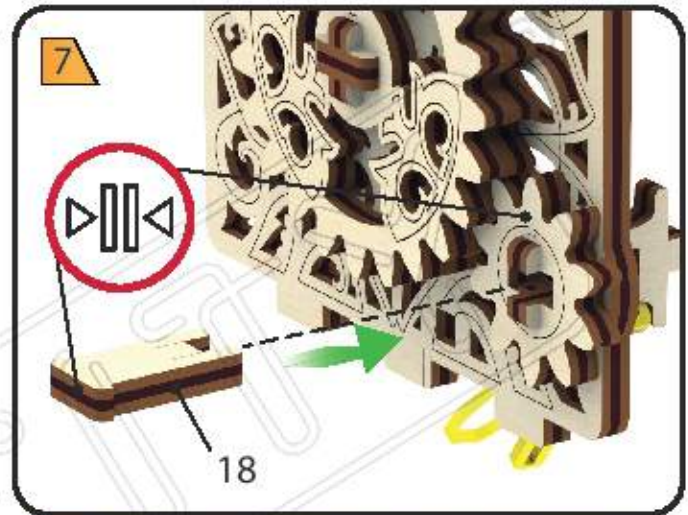
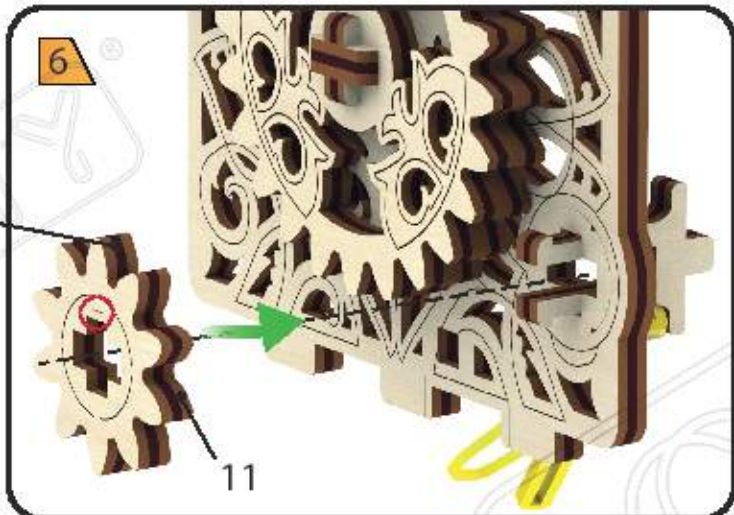
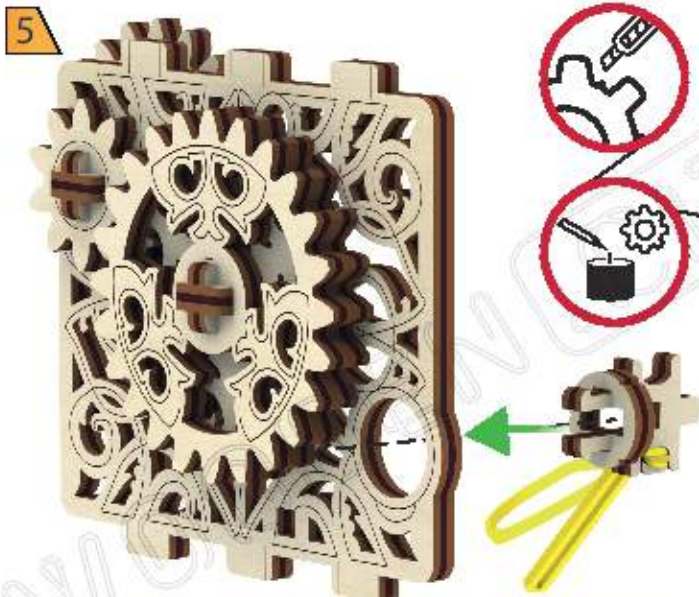

7

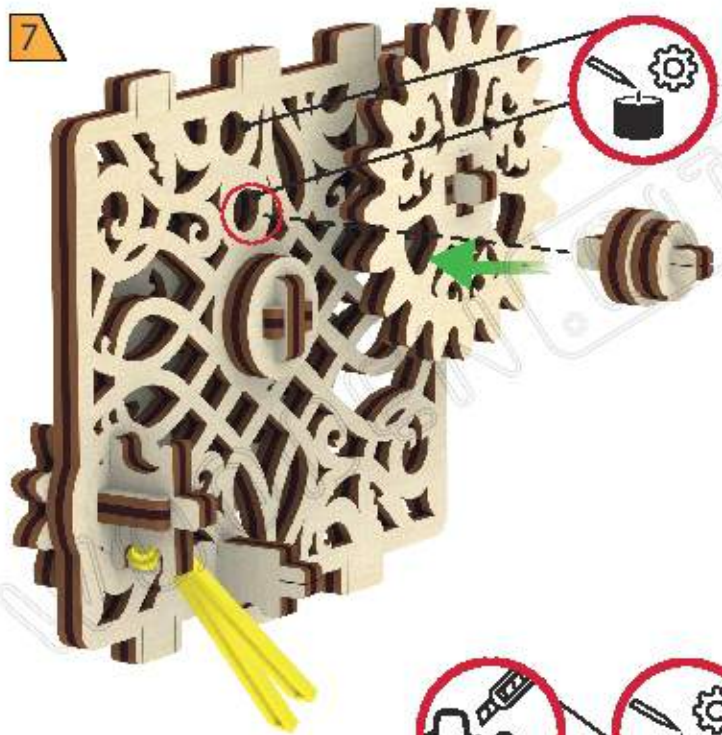

8

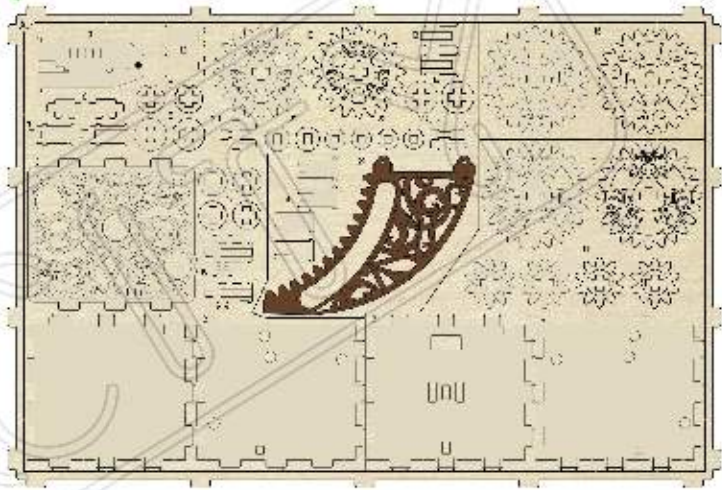
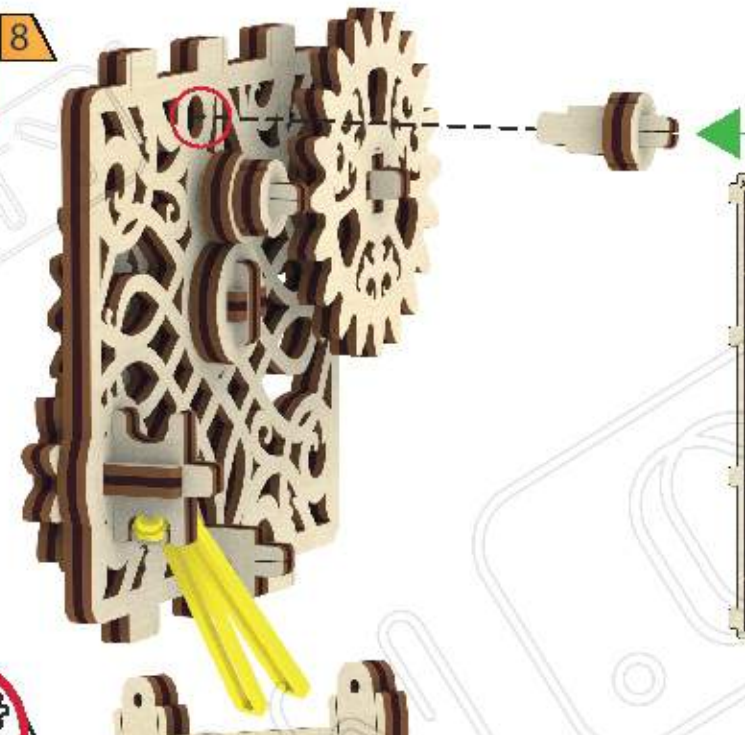

1

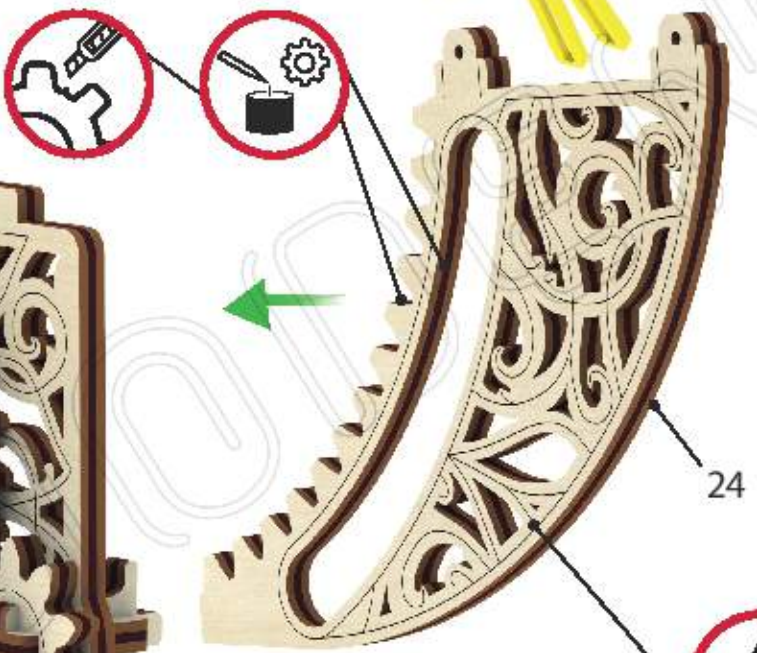

2

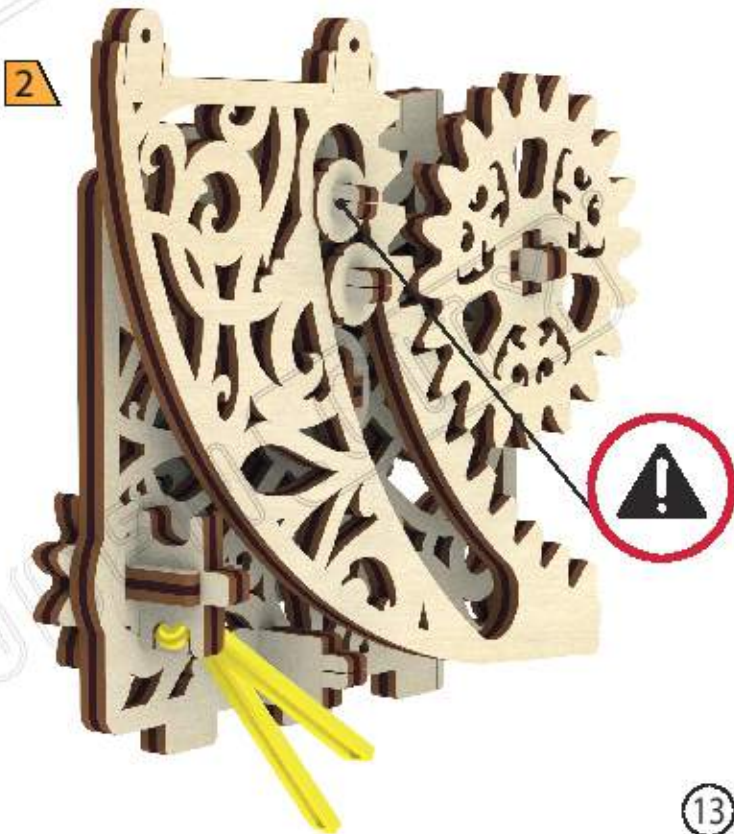

3



14

4



5

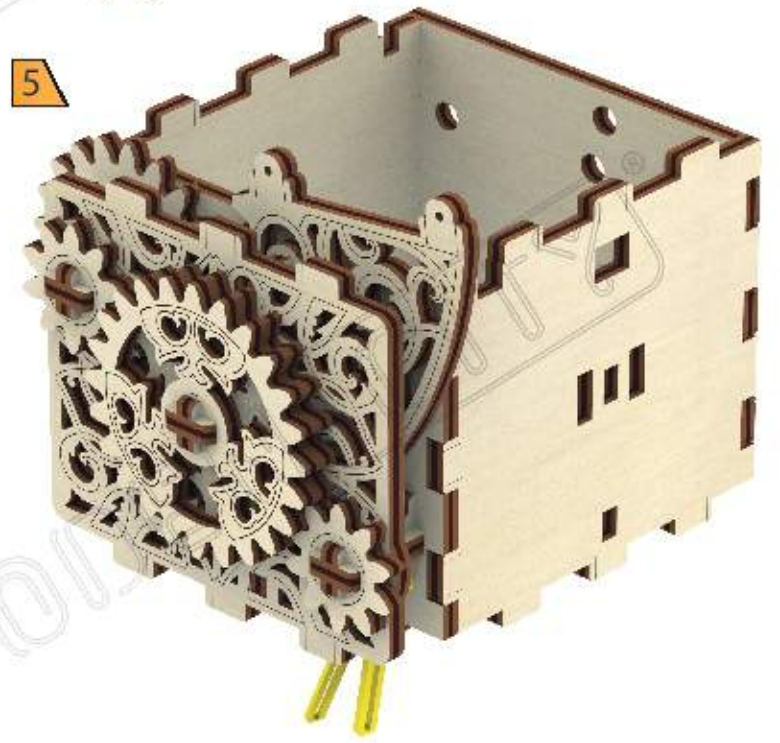

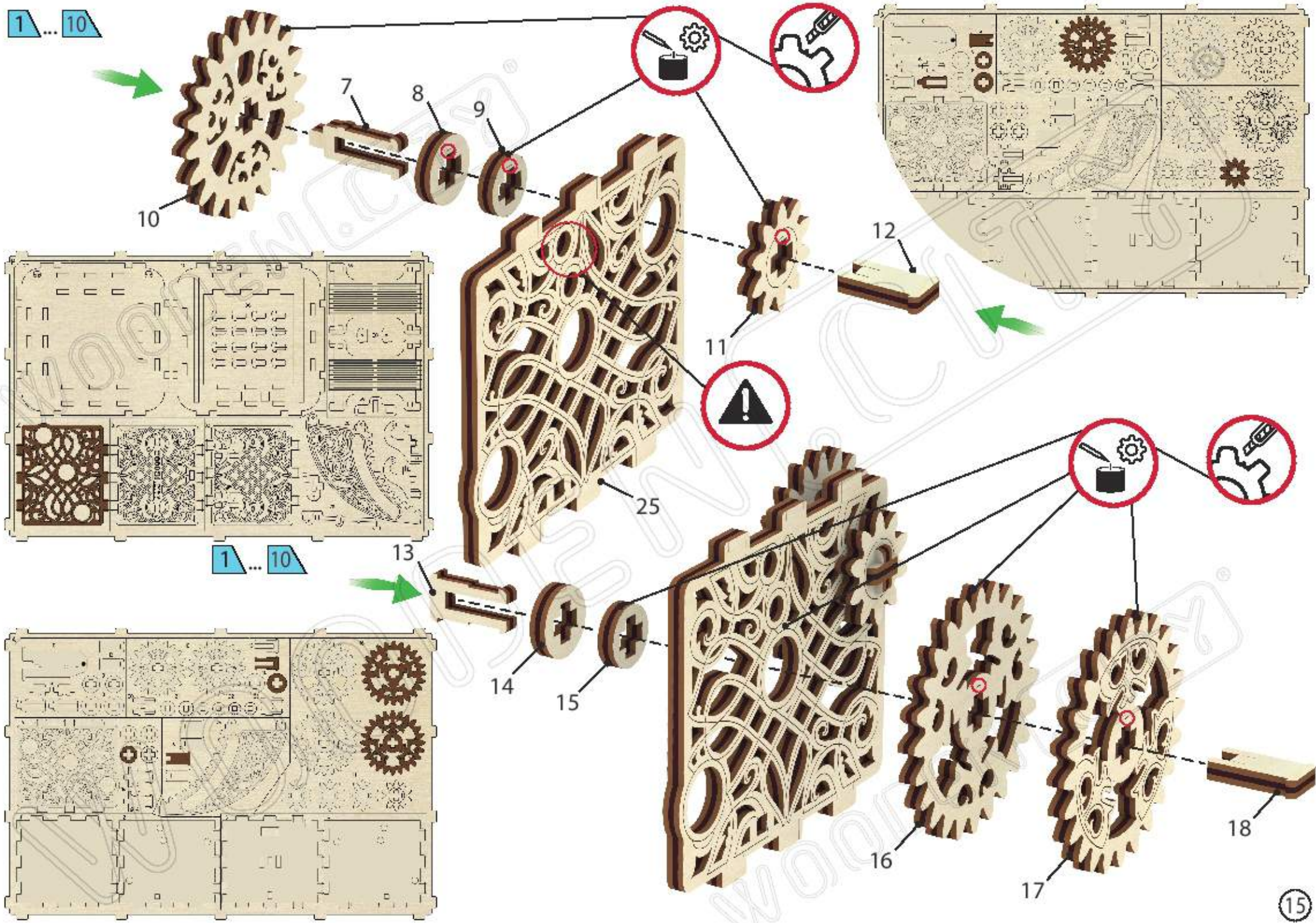

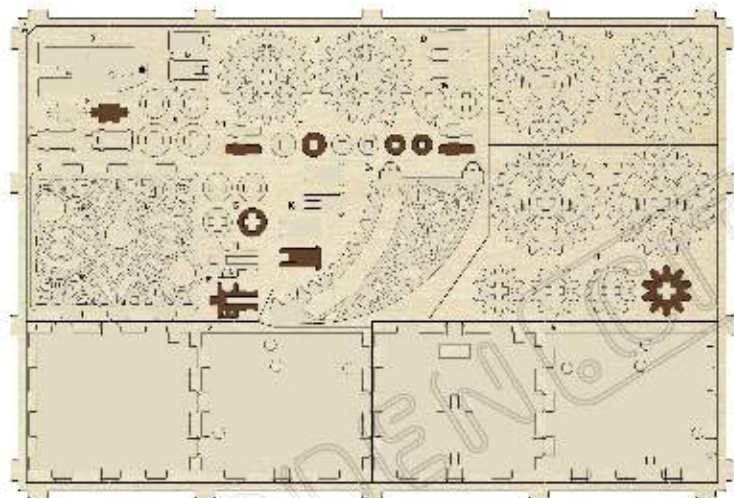

1 ... 7

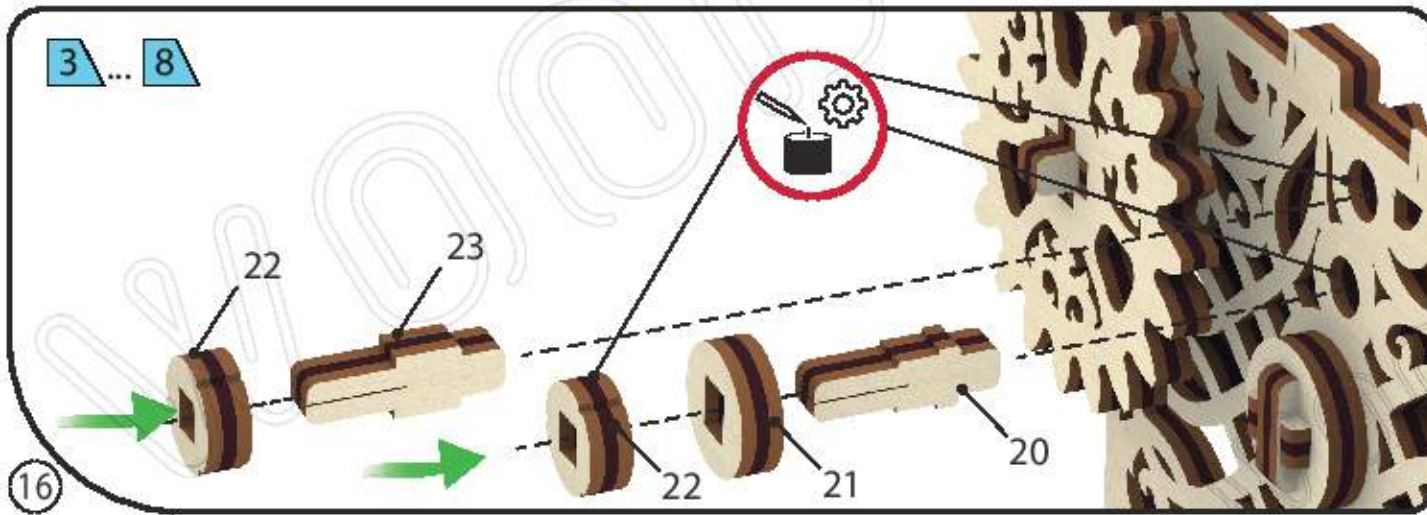
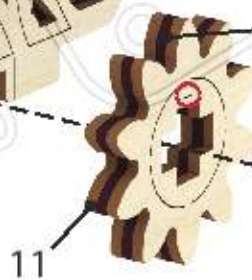
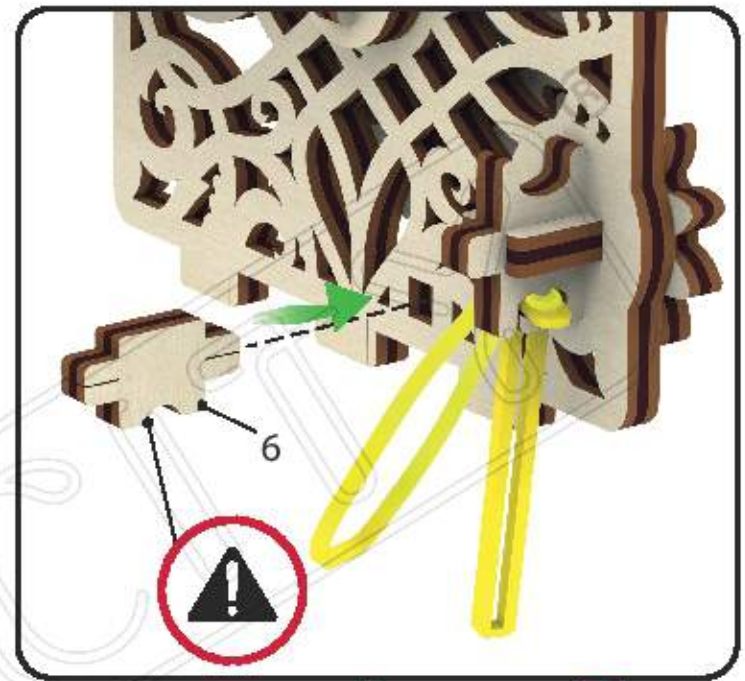
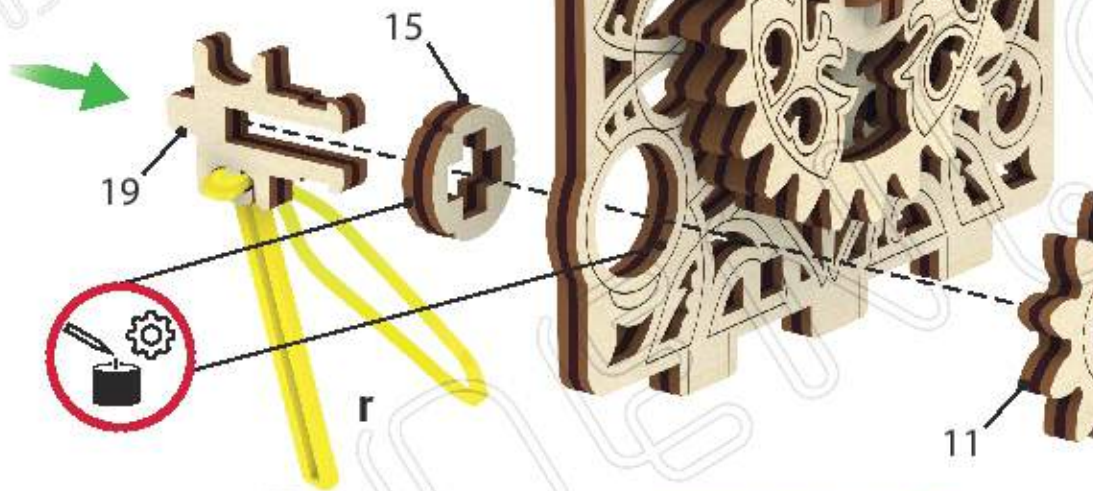

3 ... 8

16

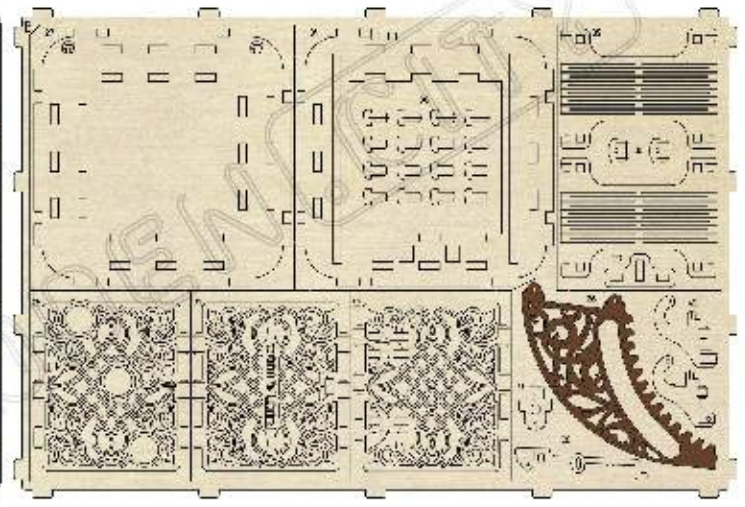



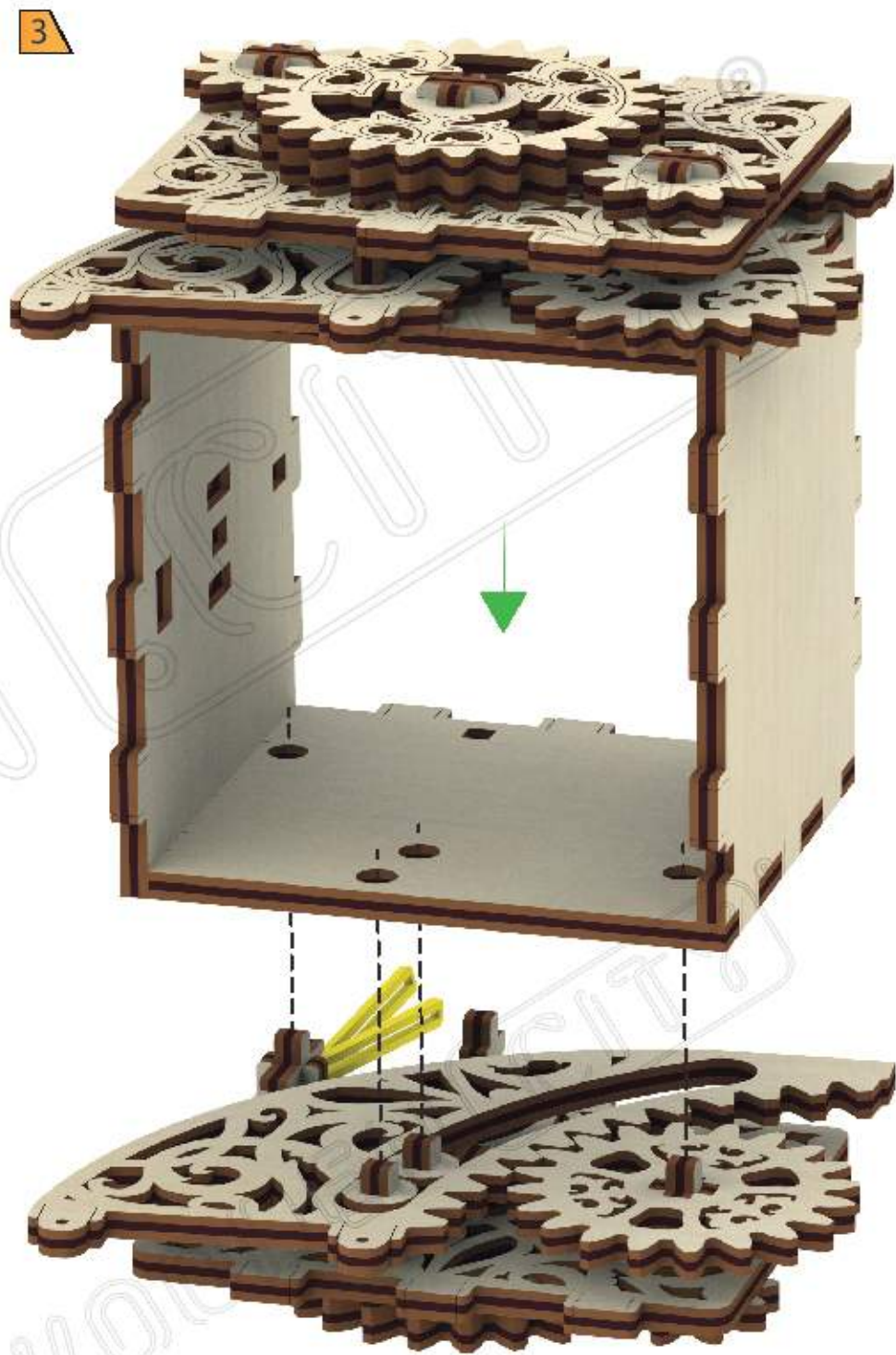
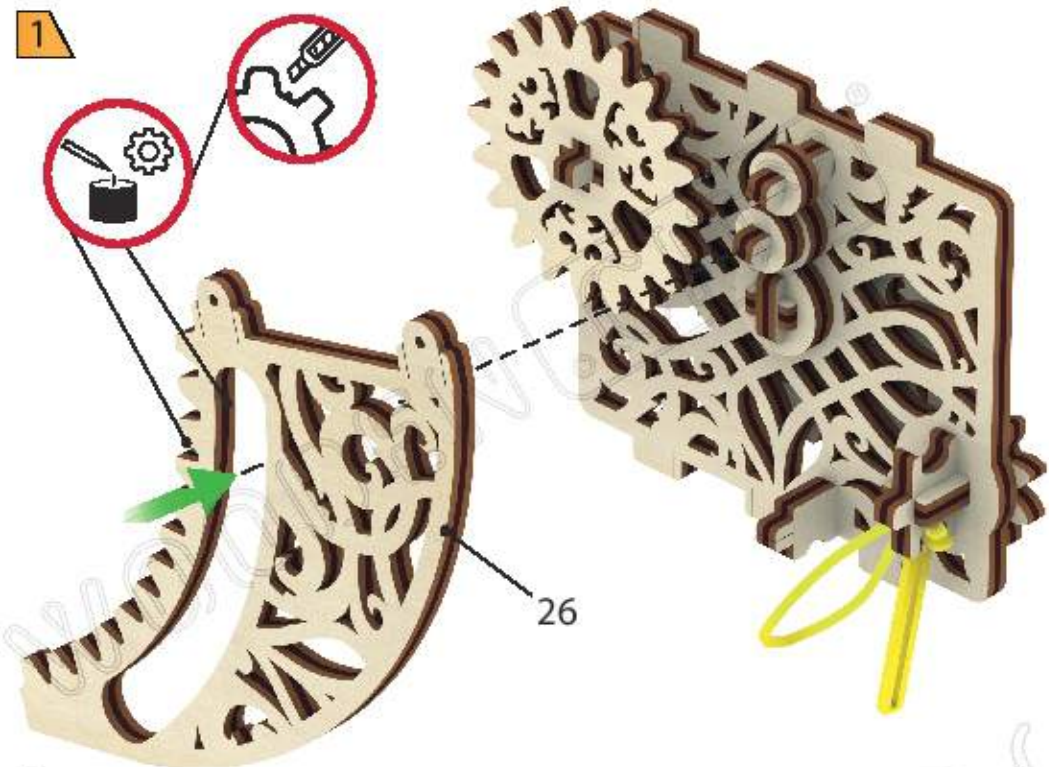

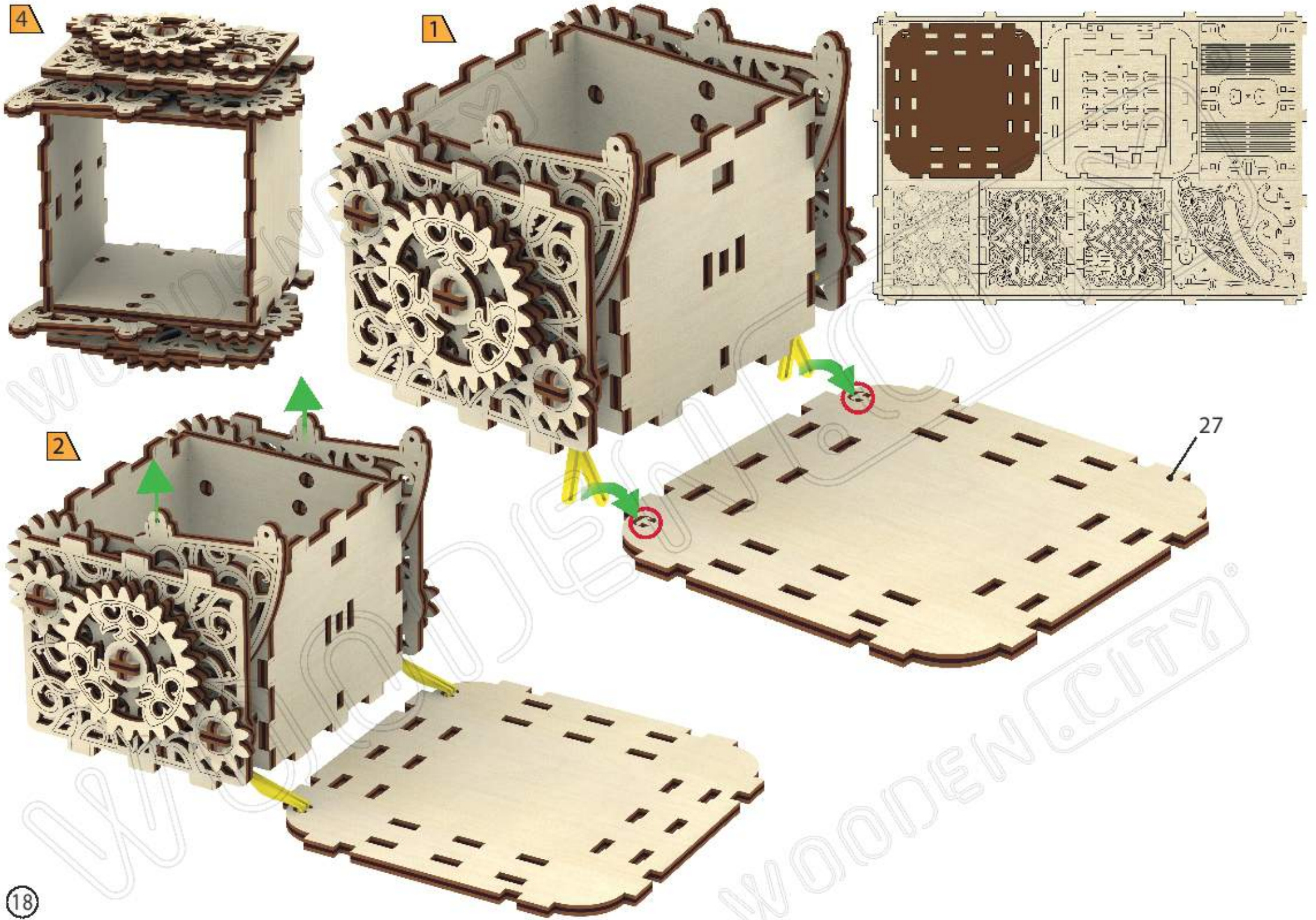

3

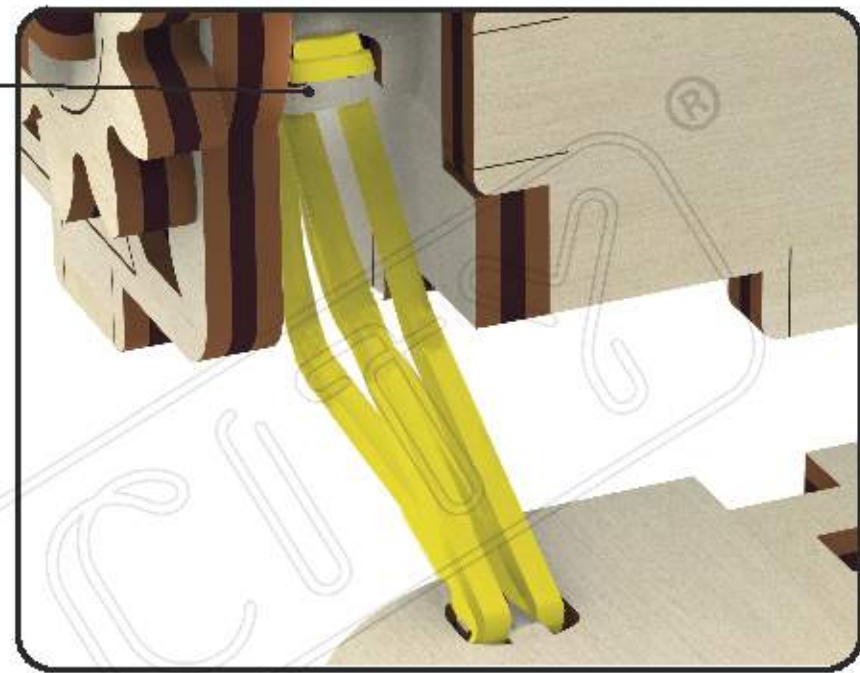
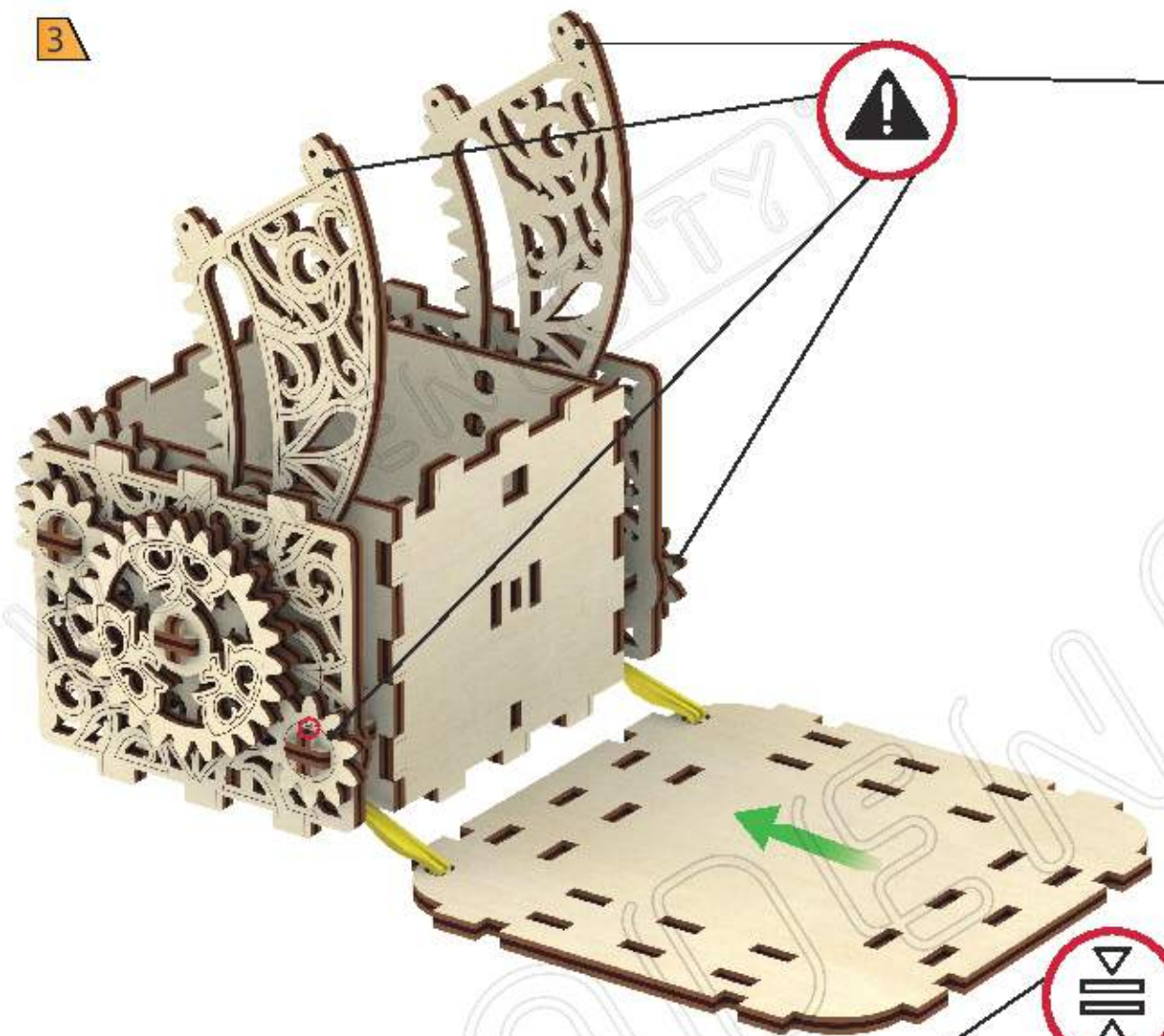

4

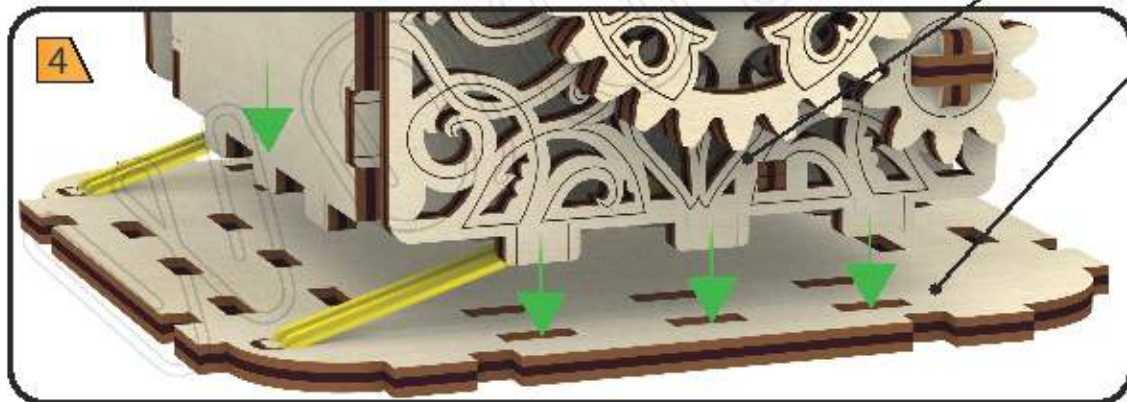

5

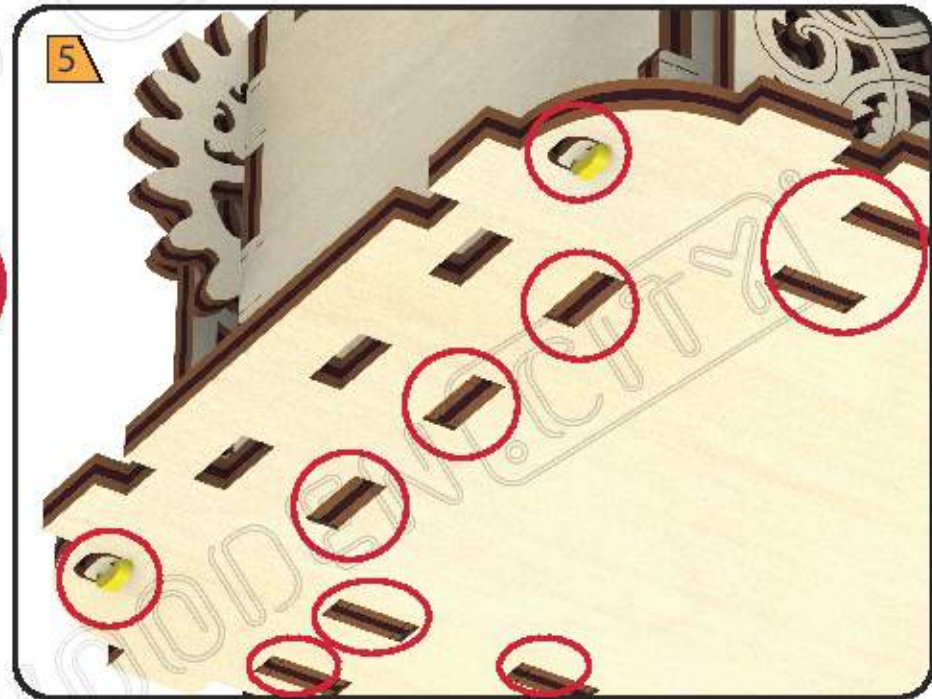

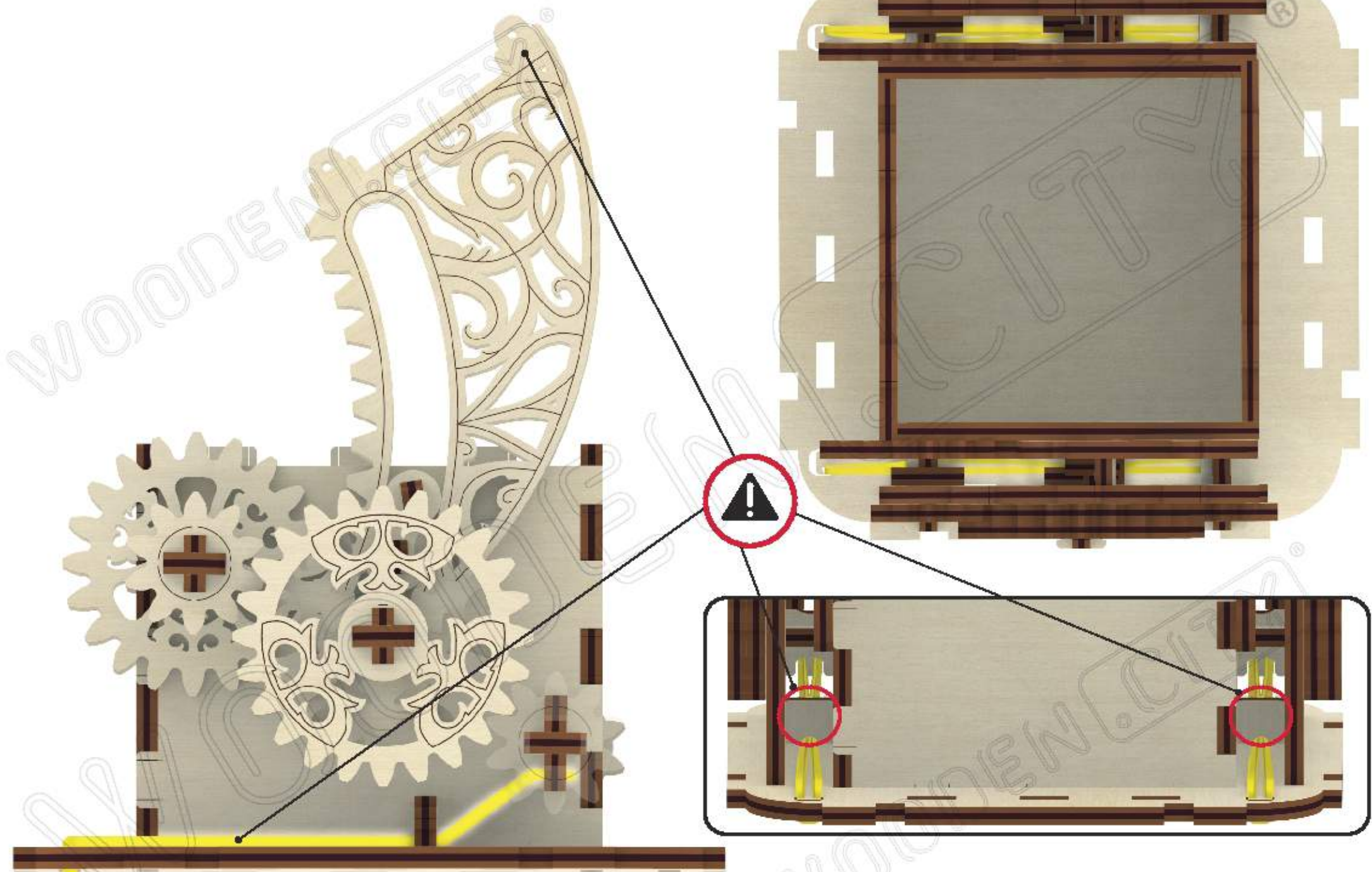

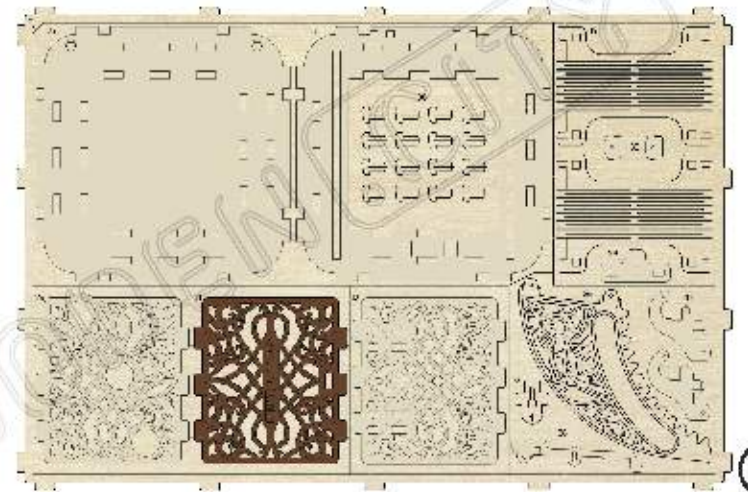
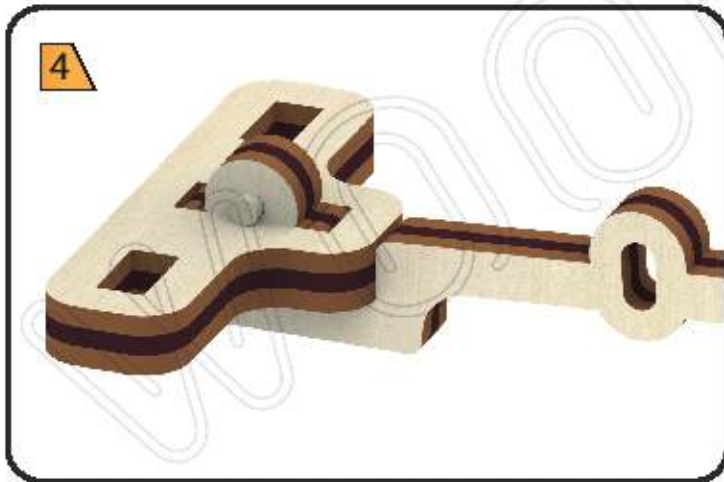
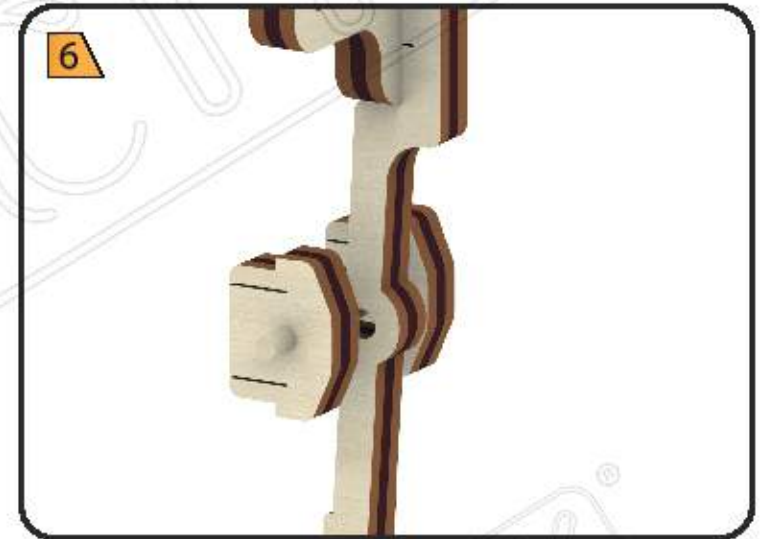
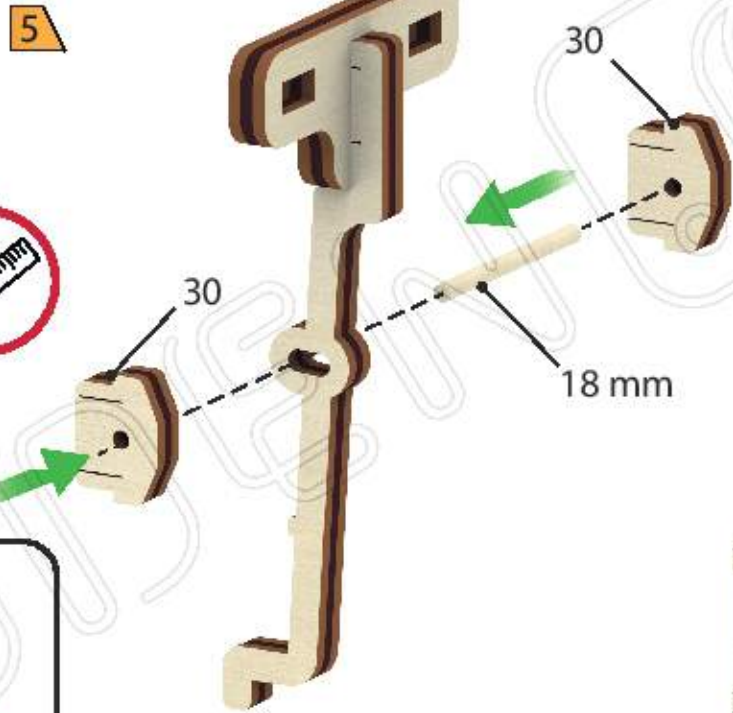
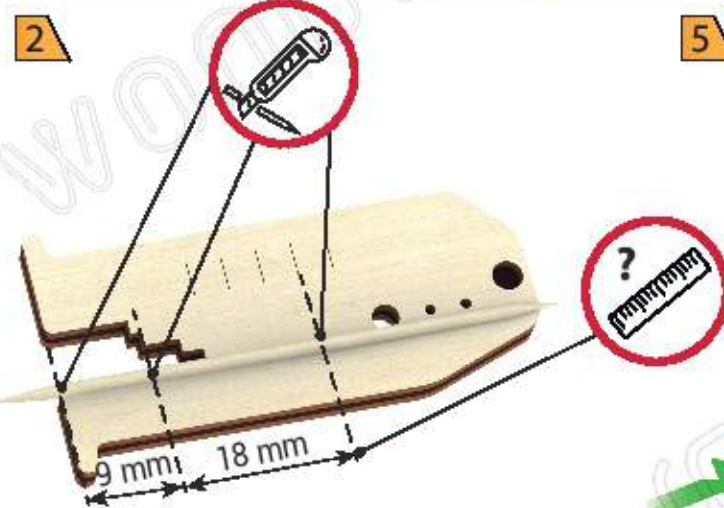
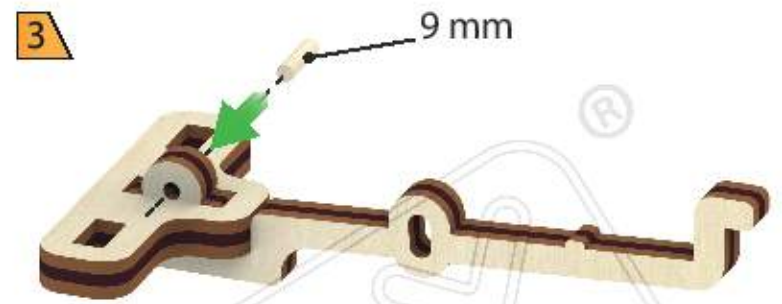
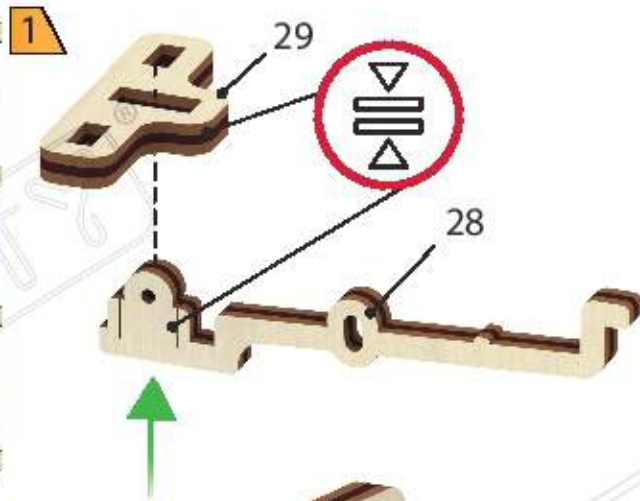
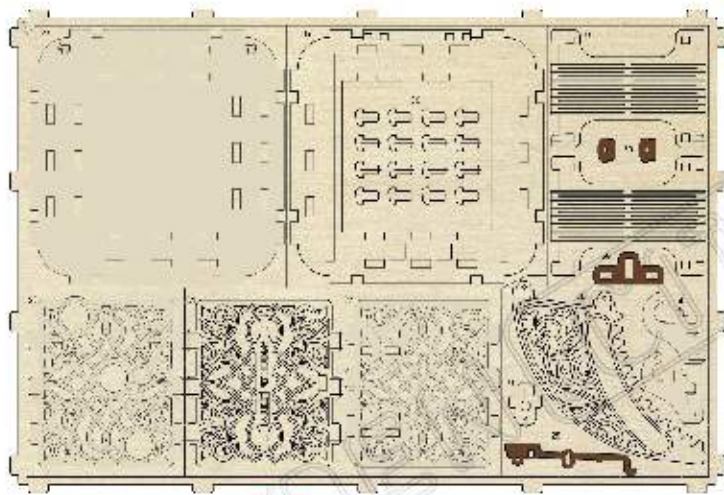

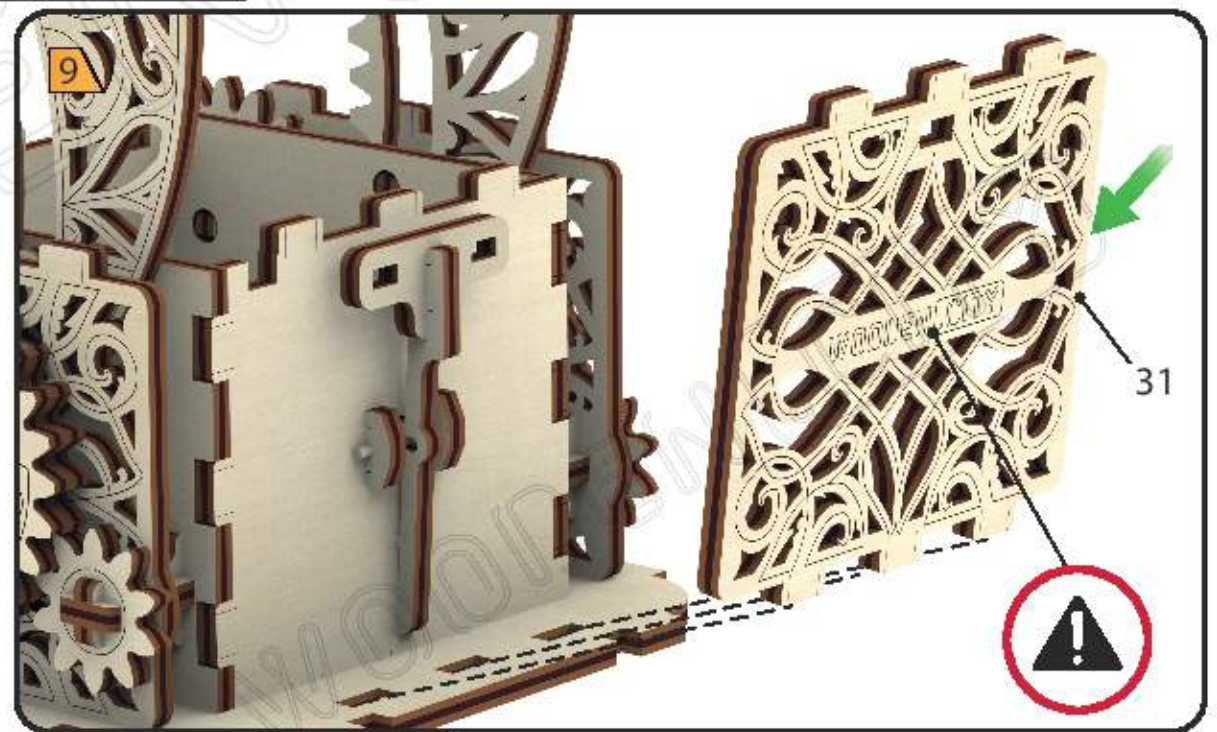
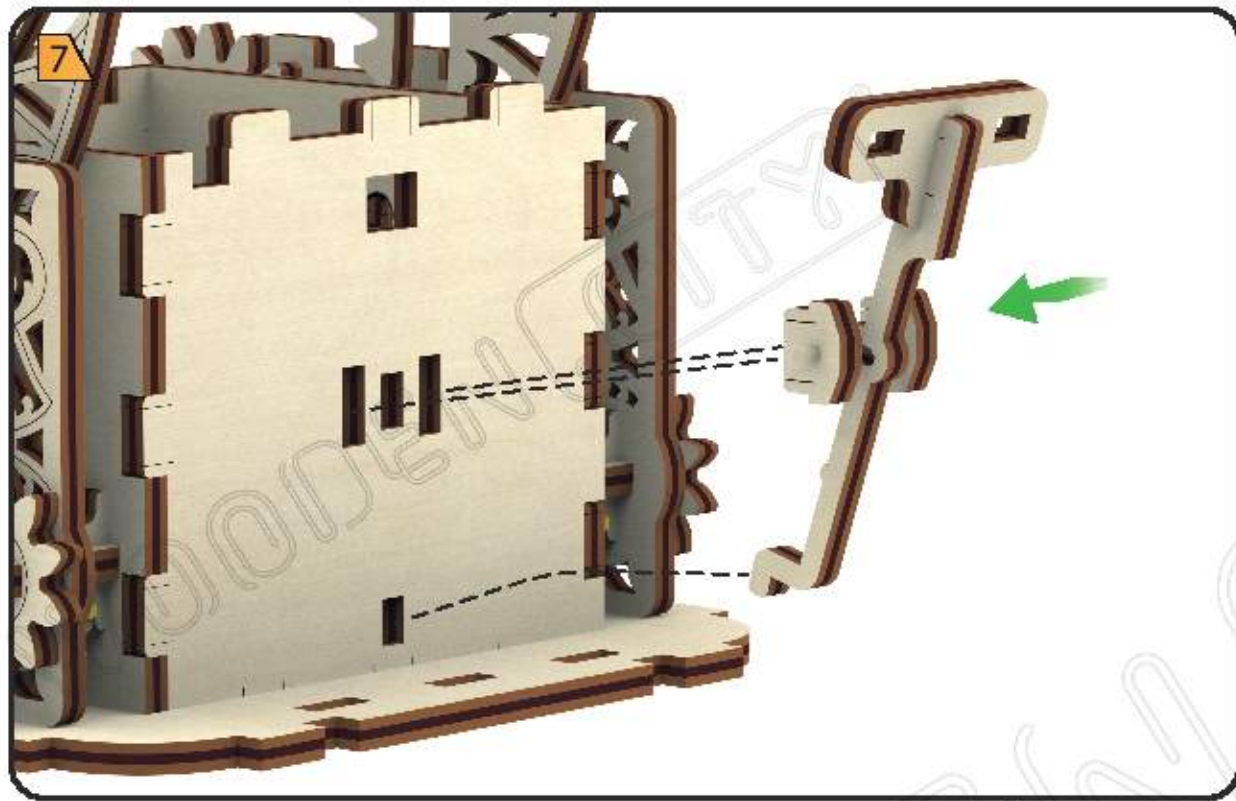

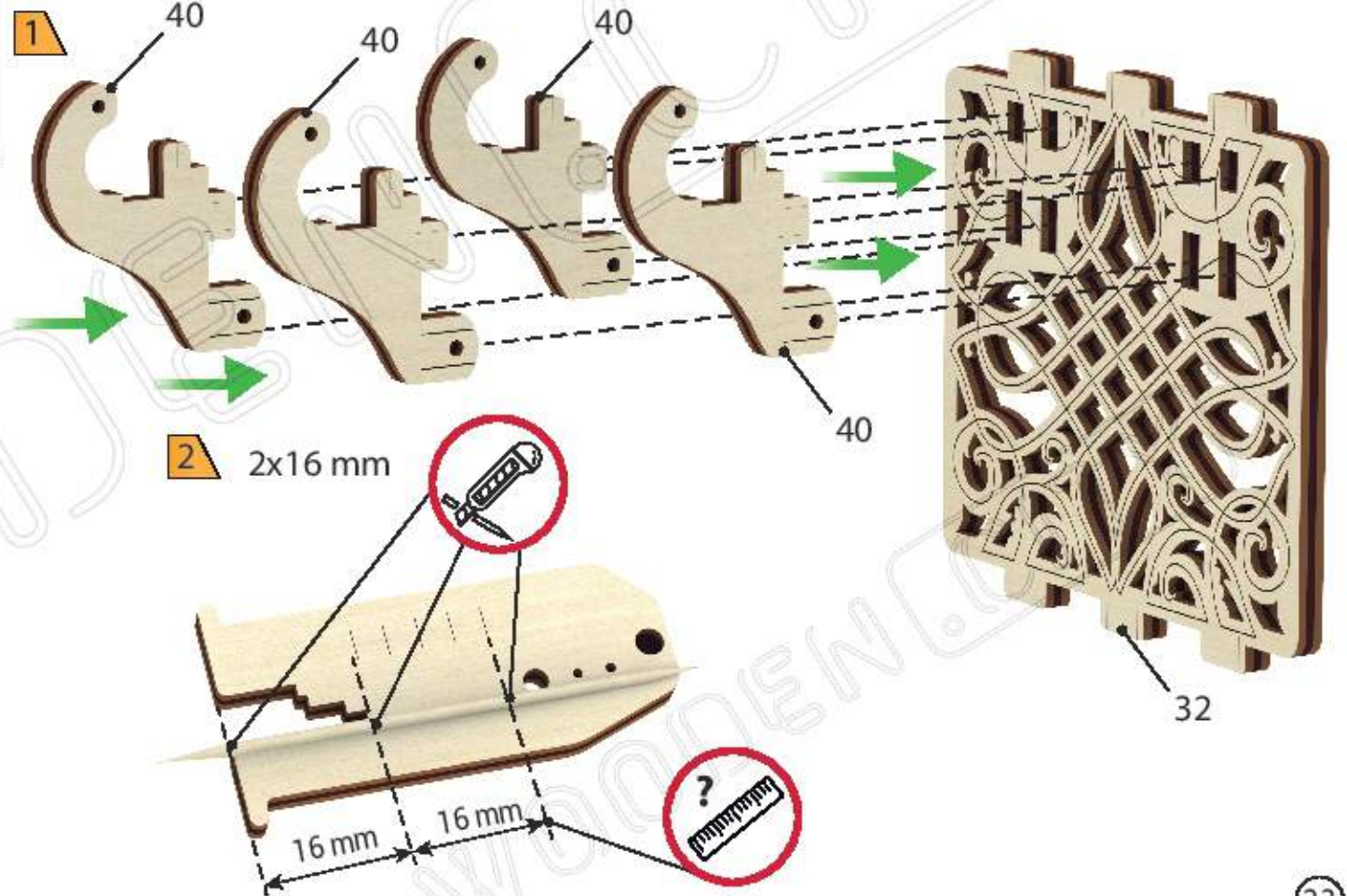
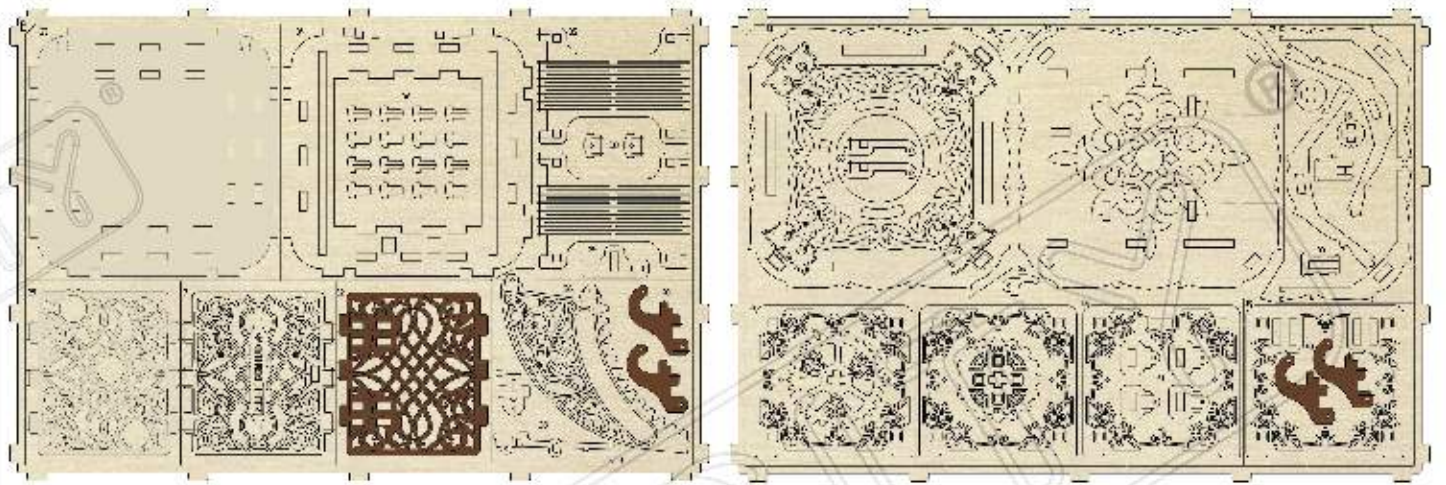

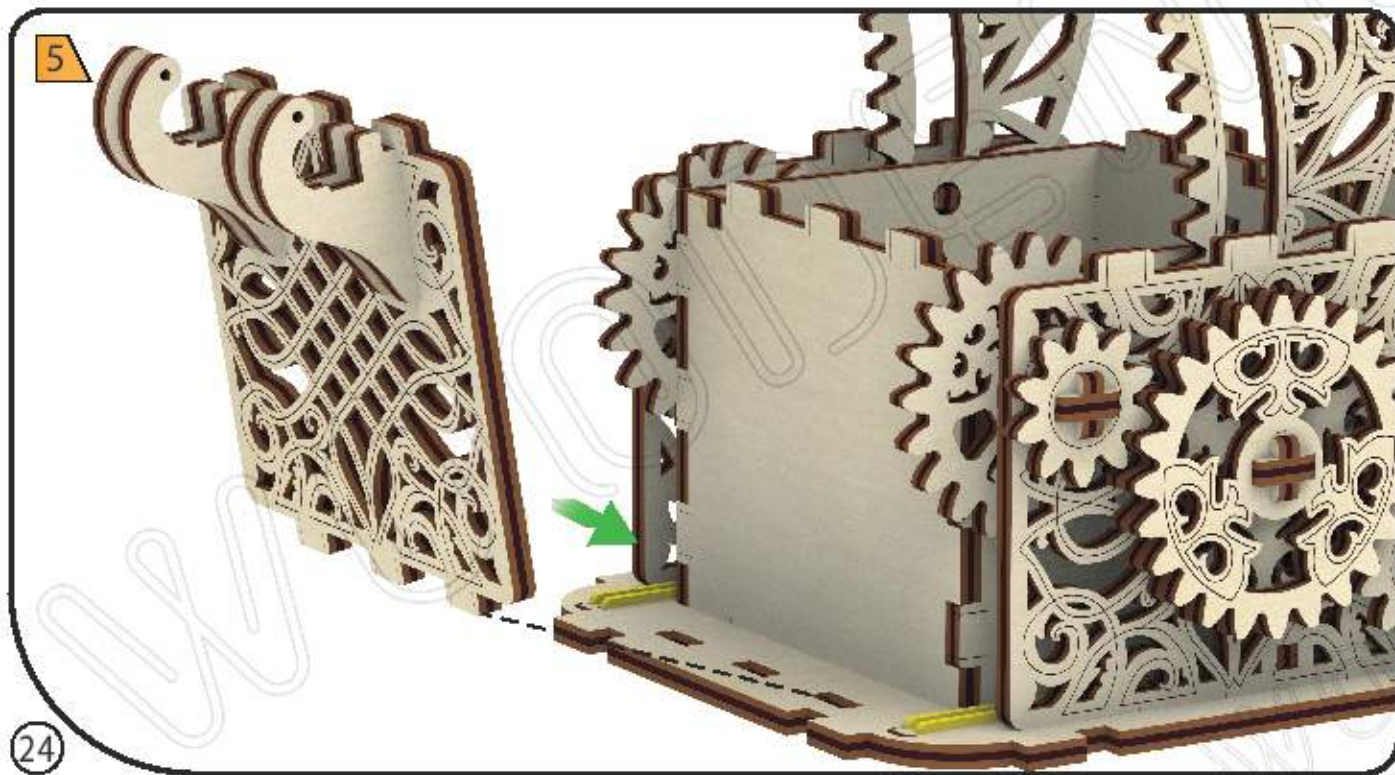
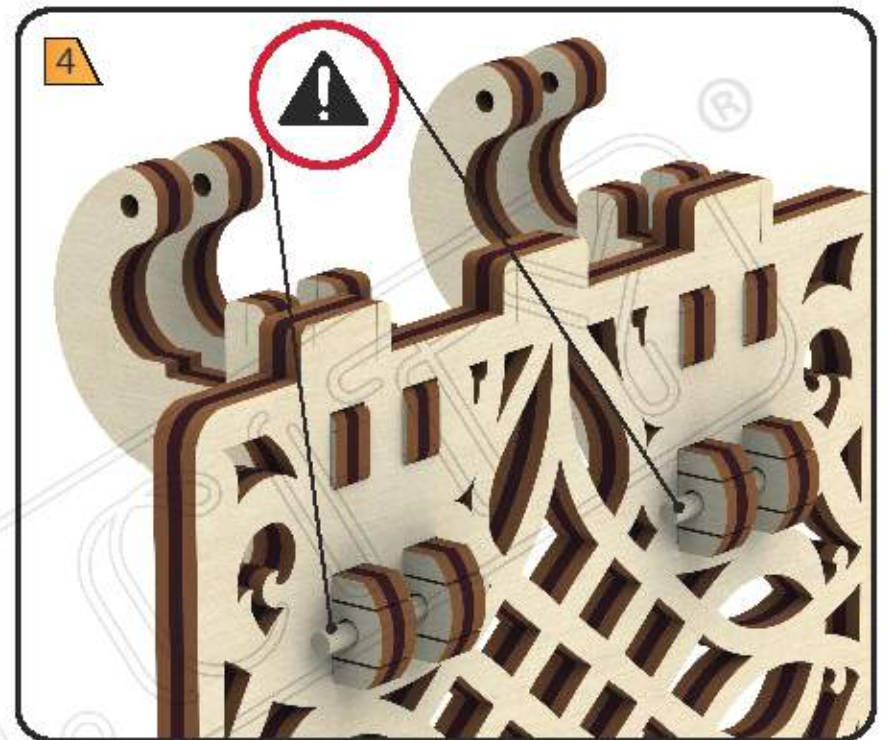
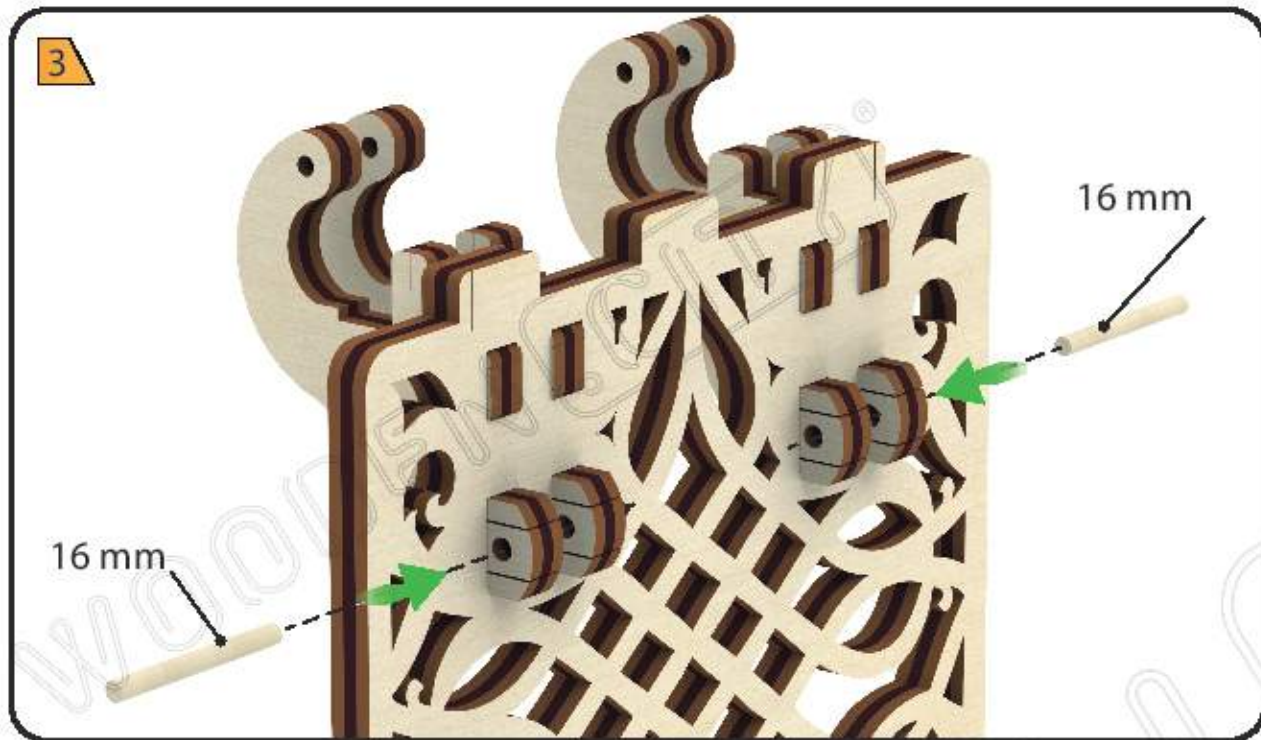



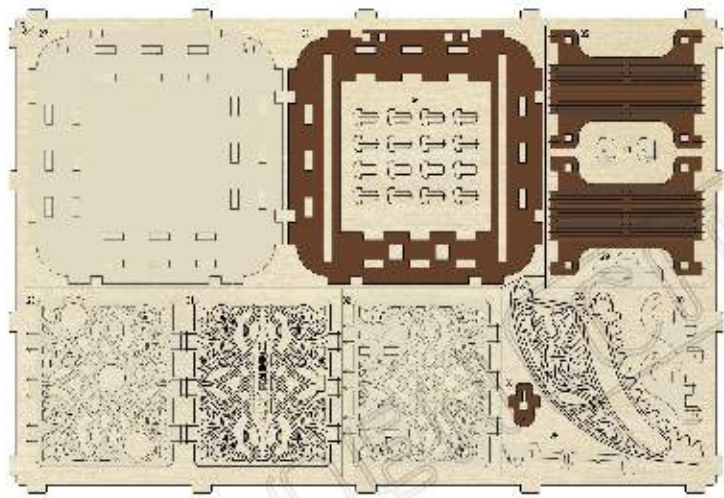

2

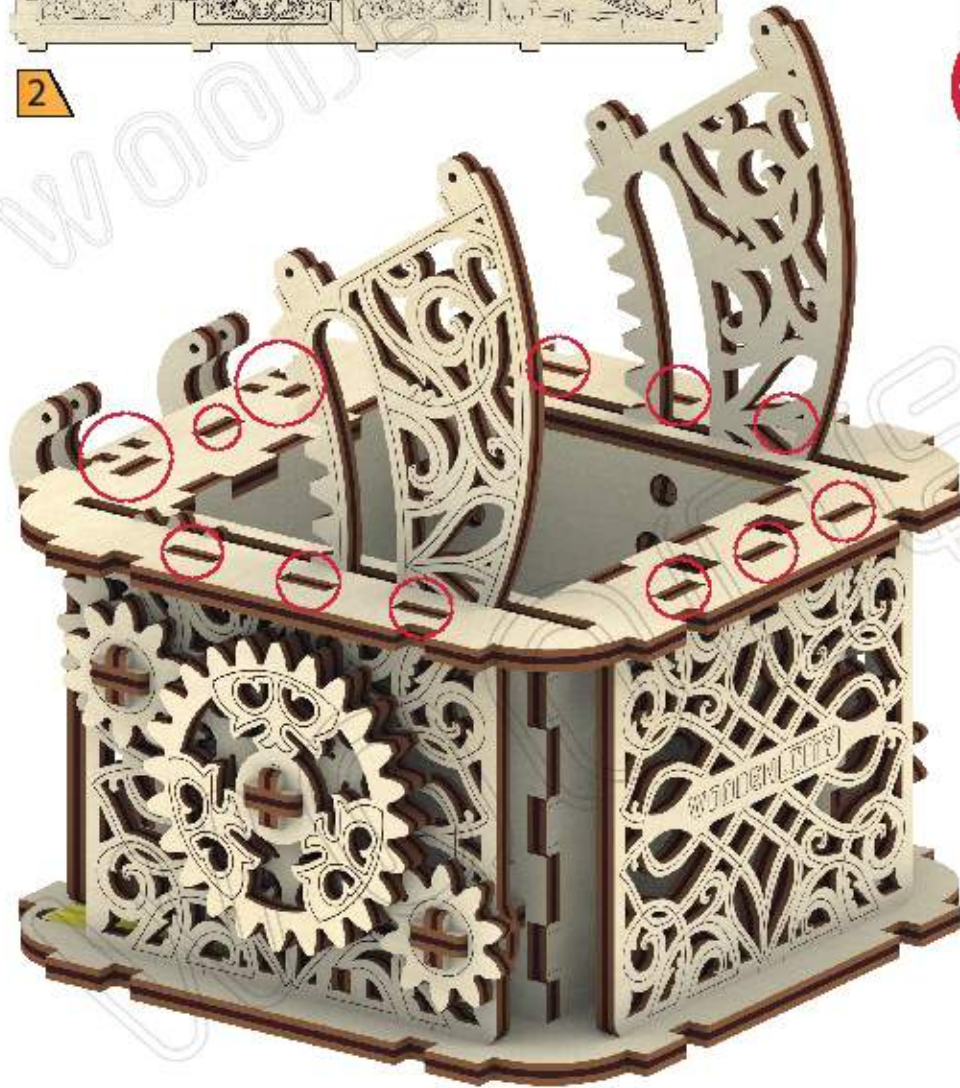

1

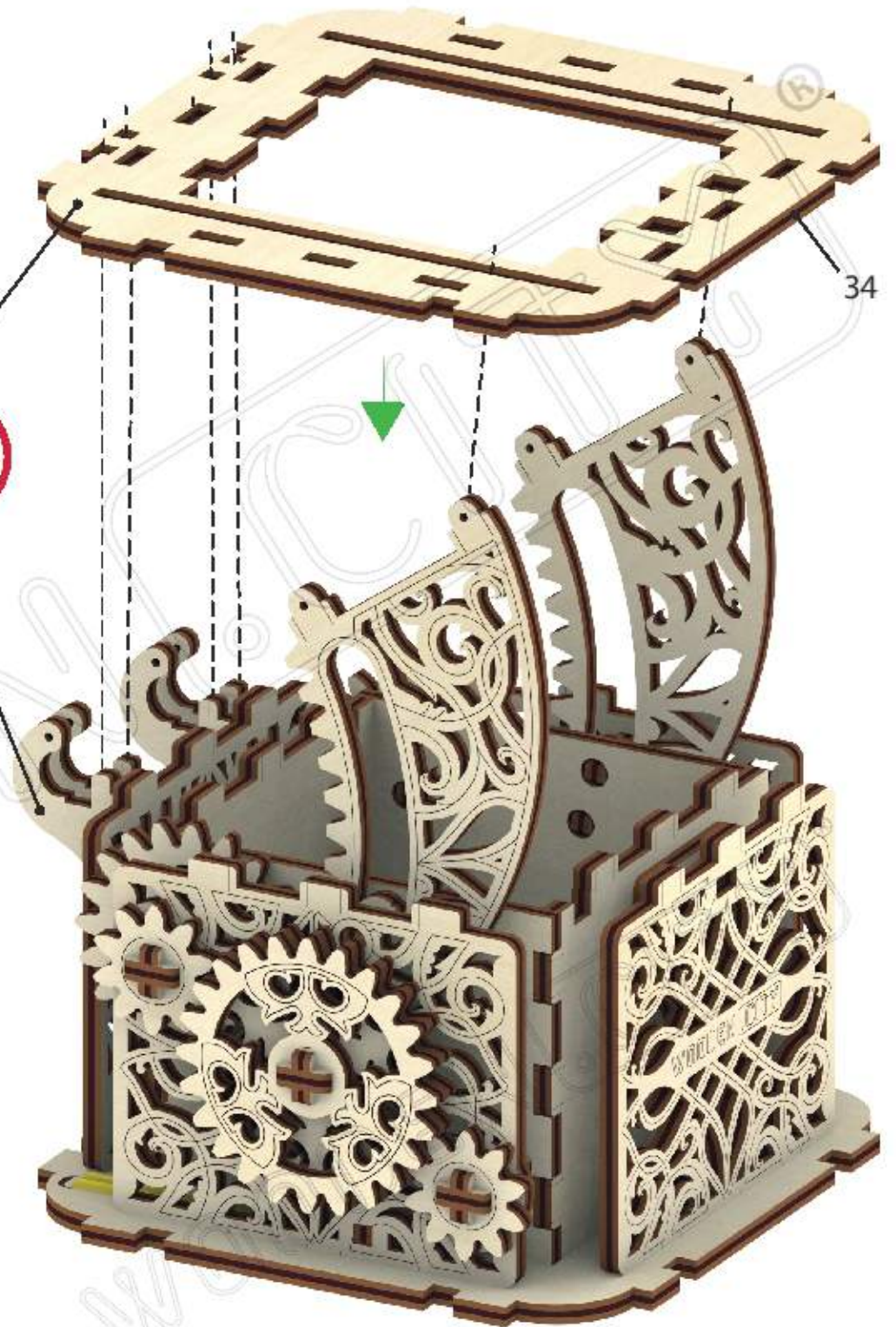

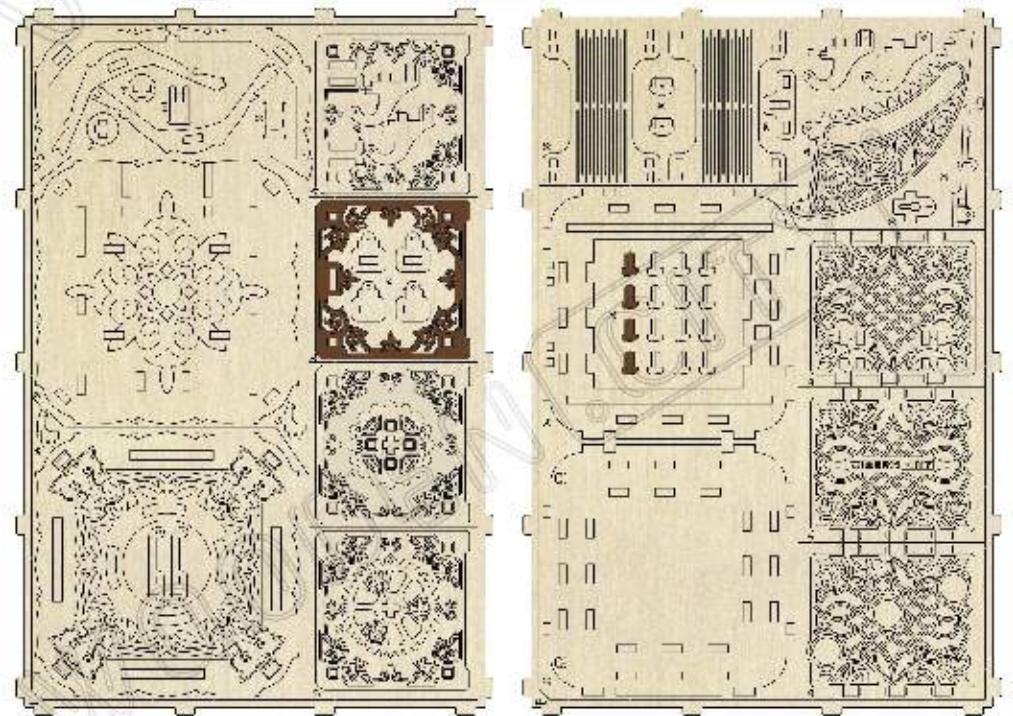
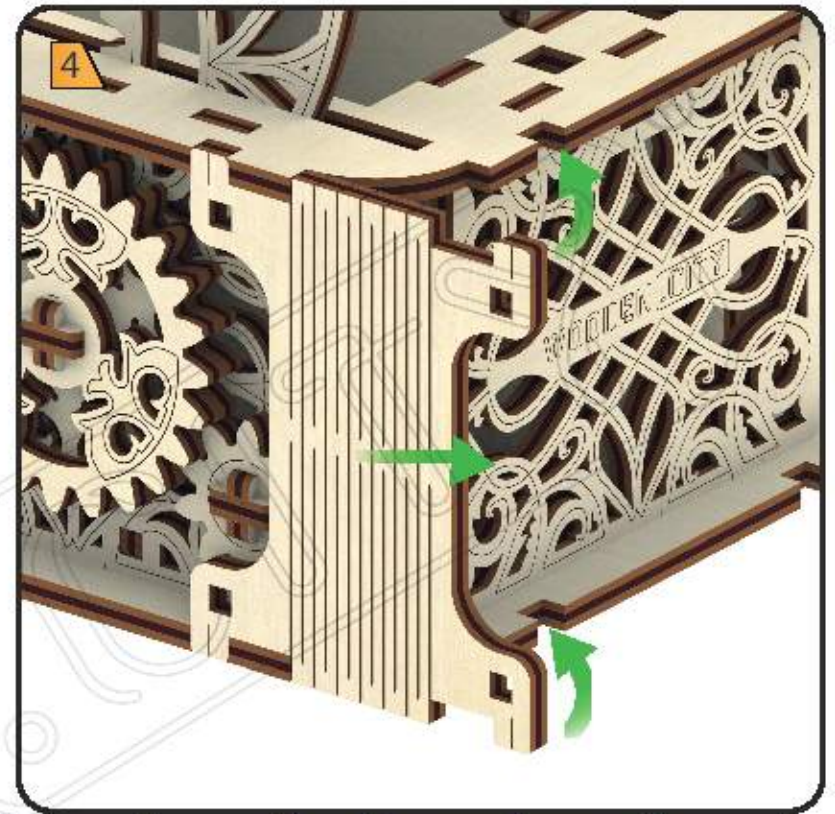
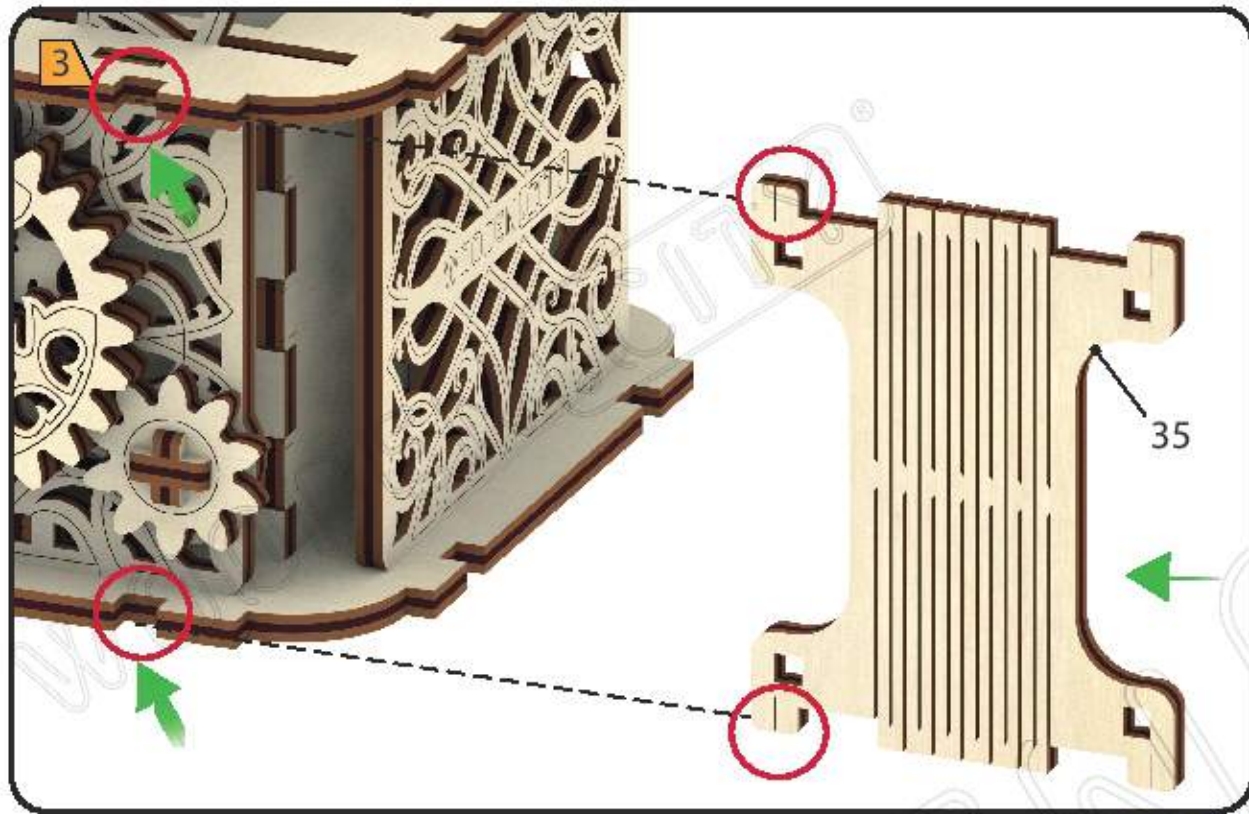

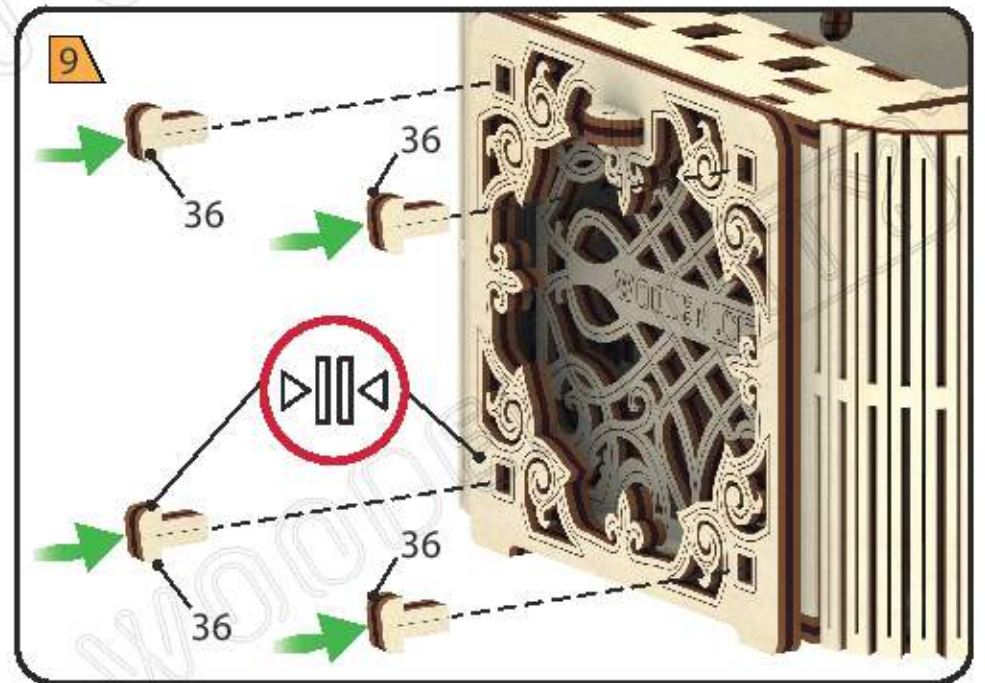
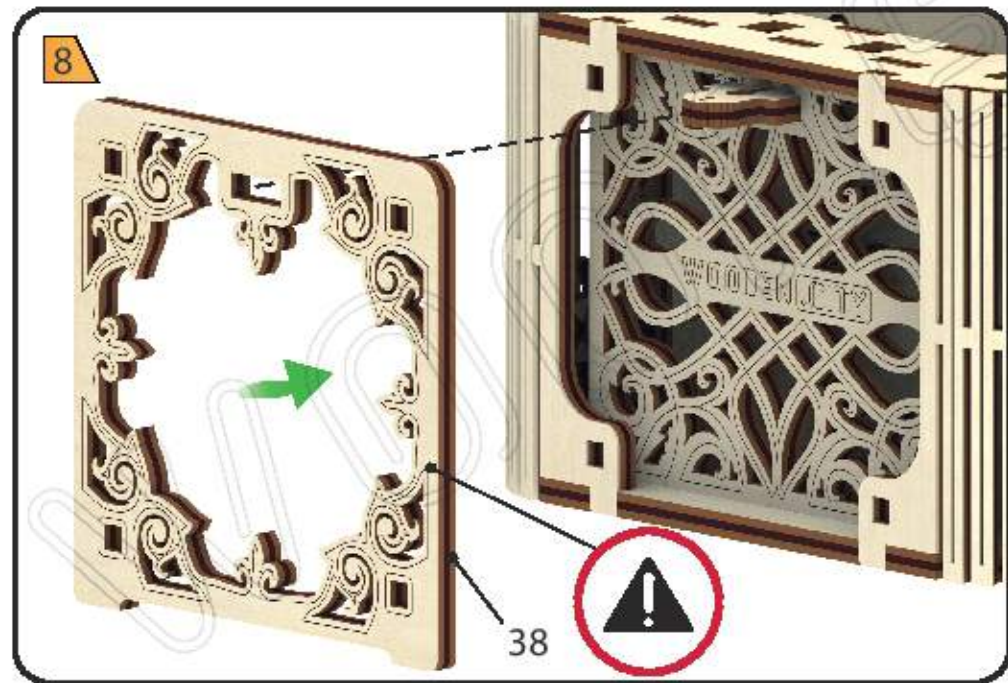
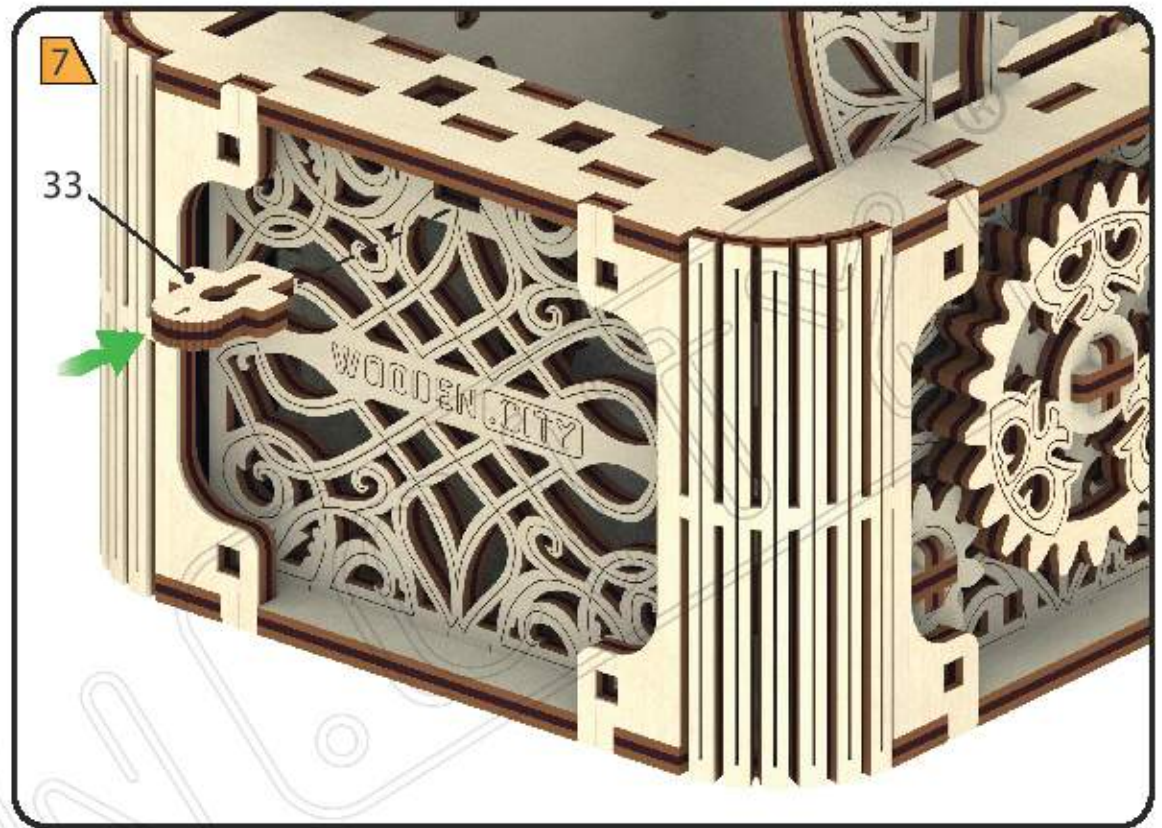
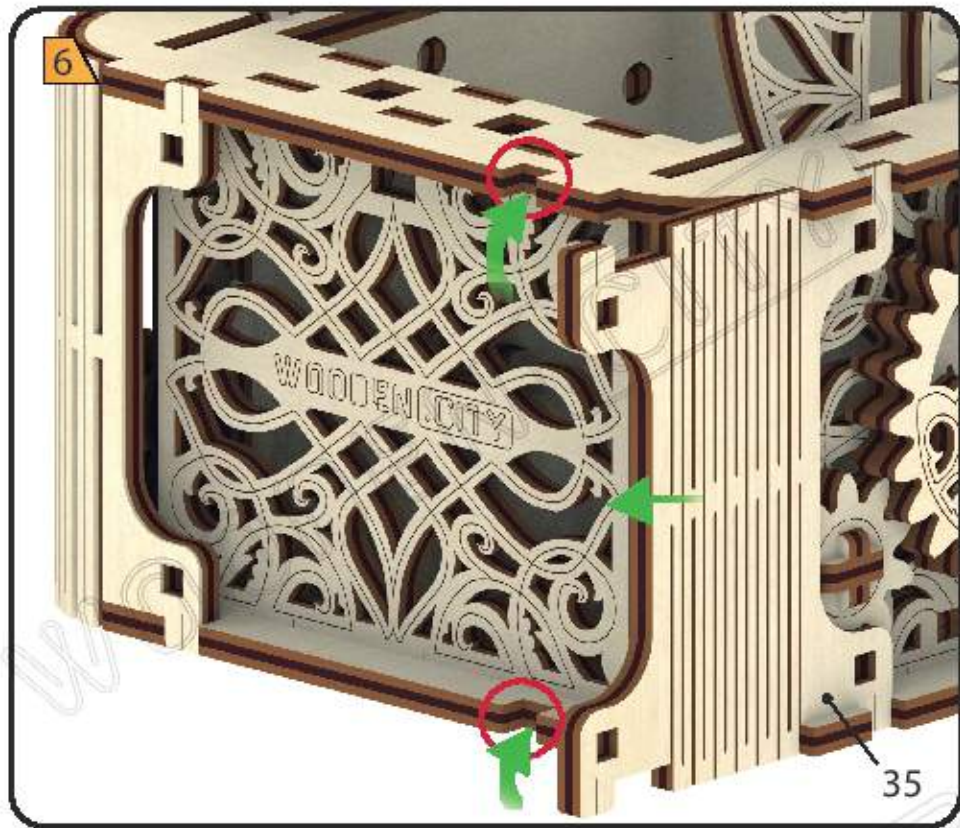

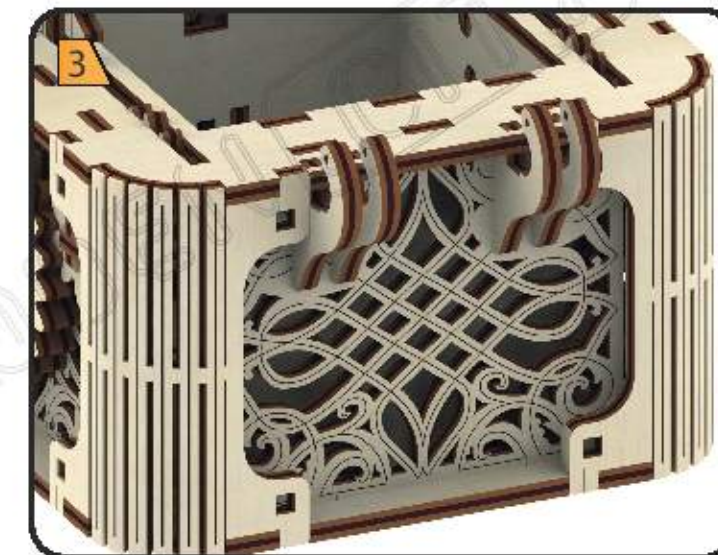
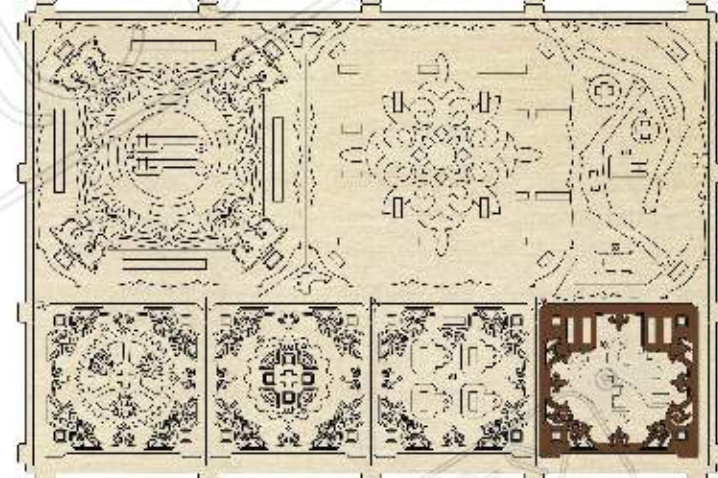
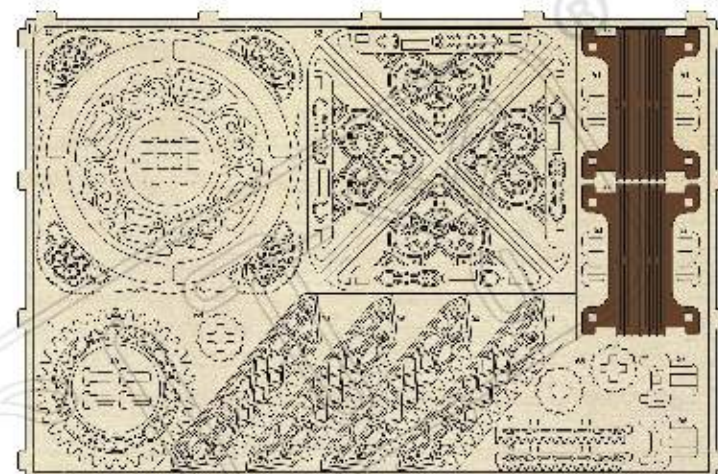
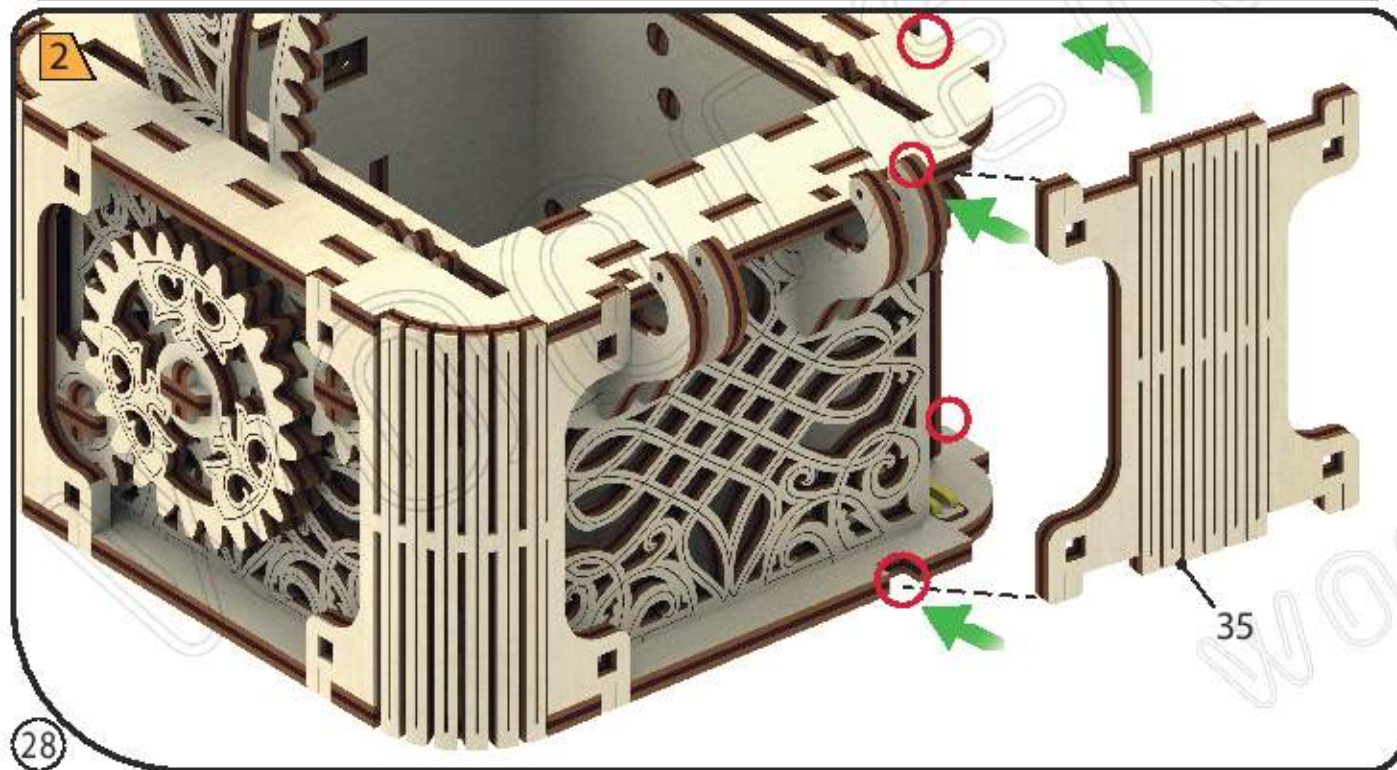
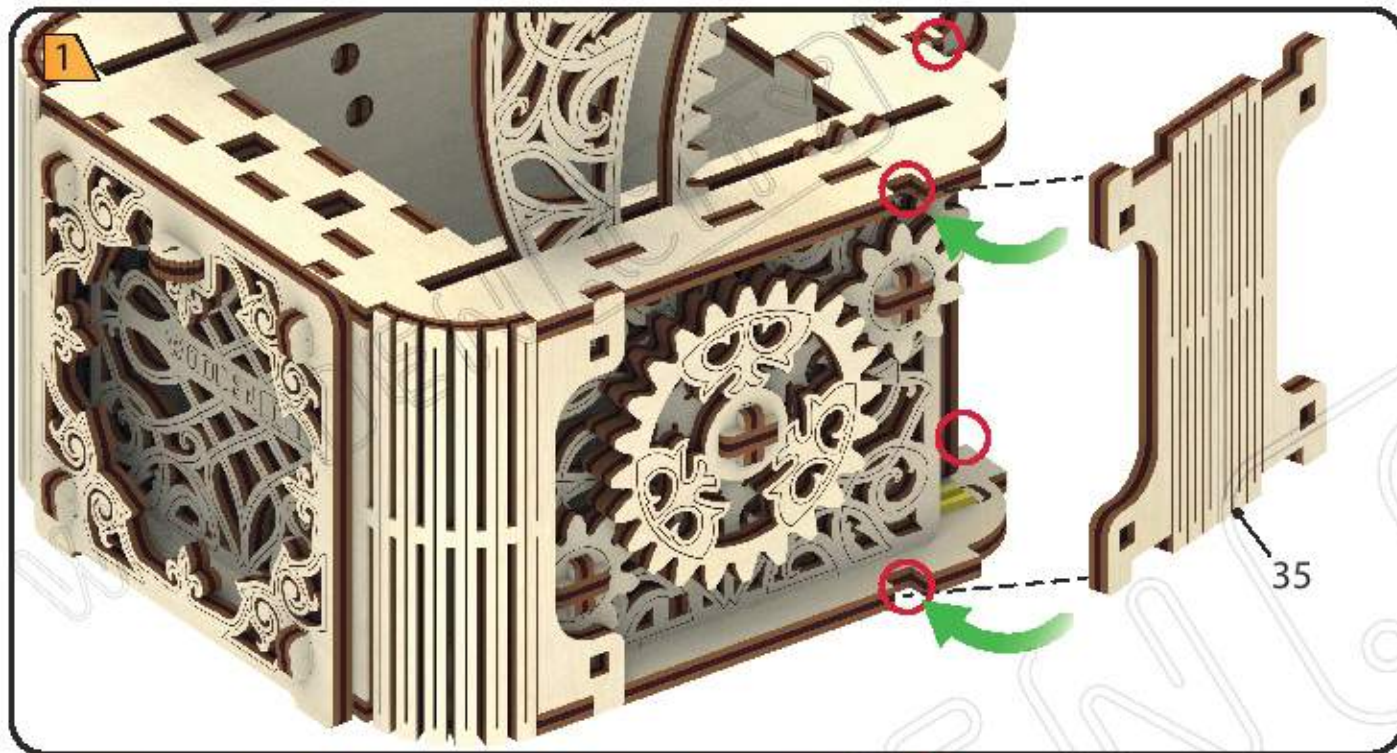

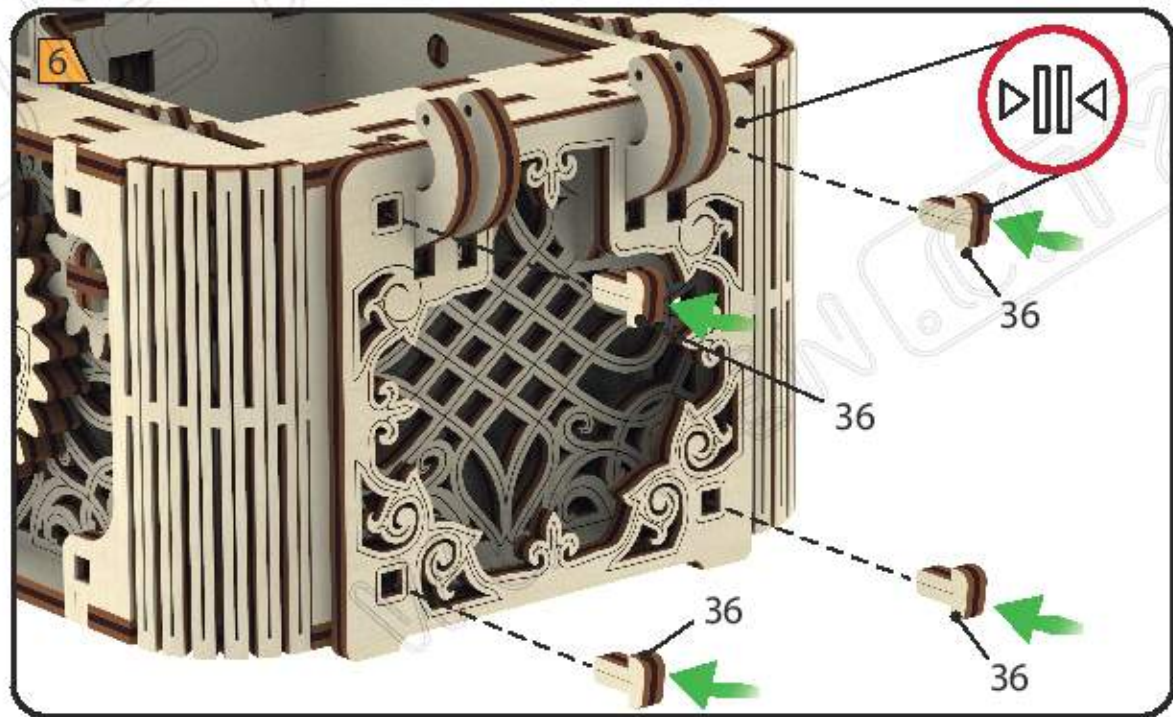
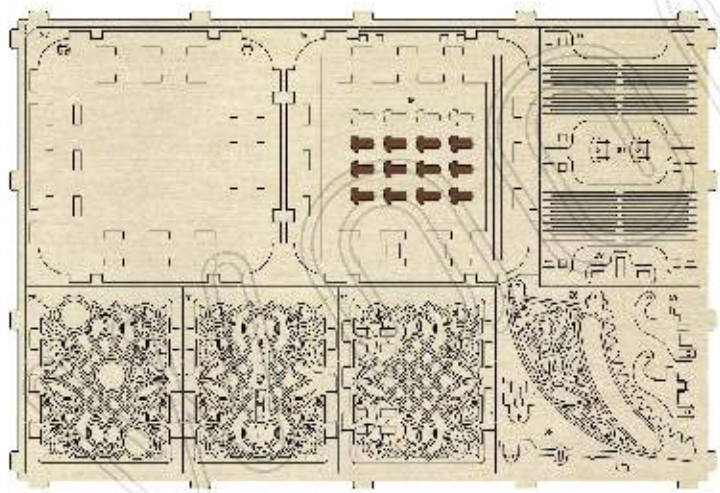
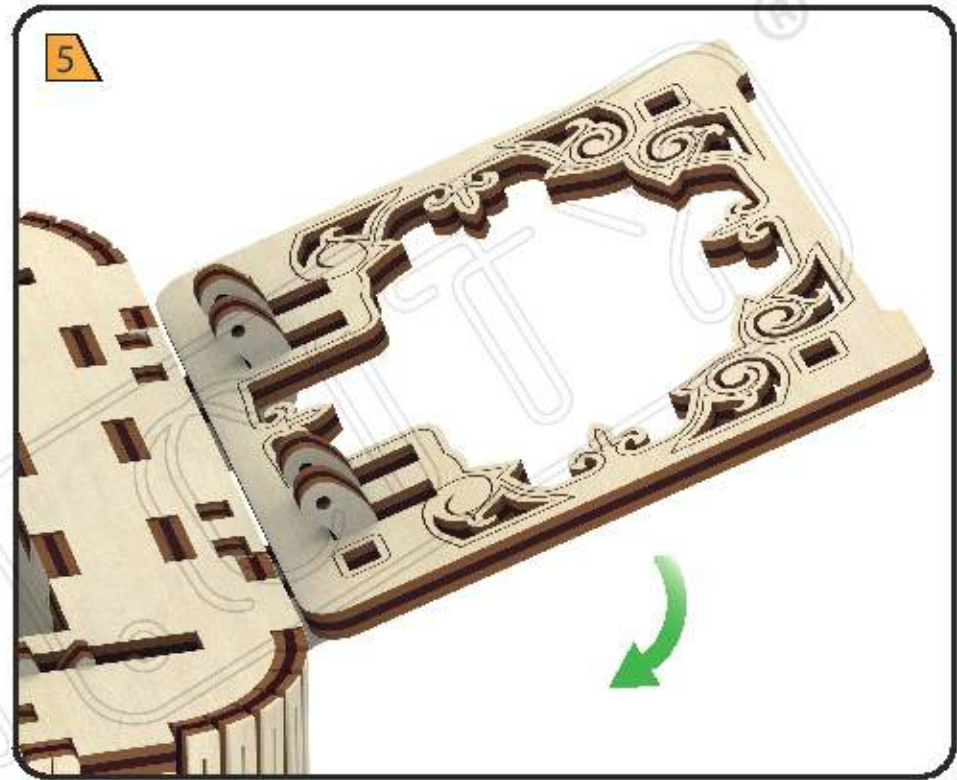
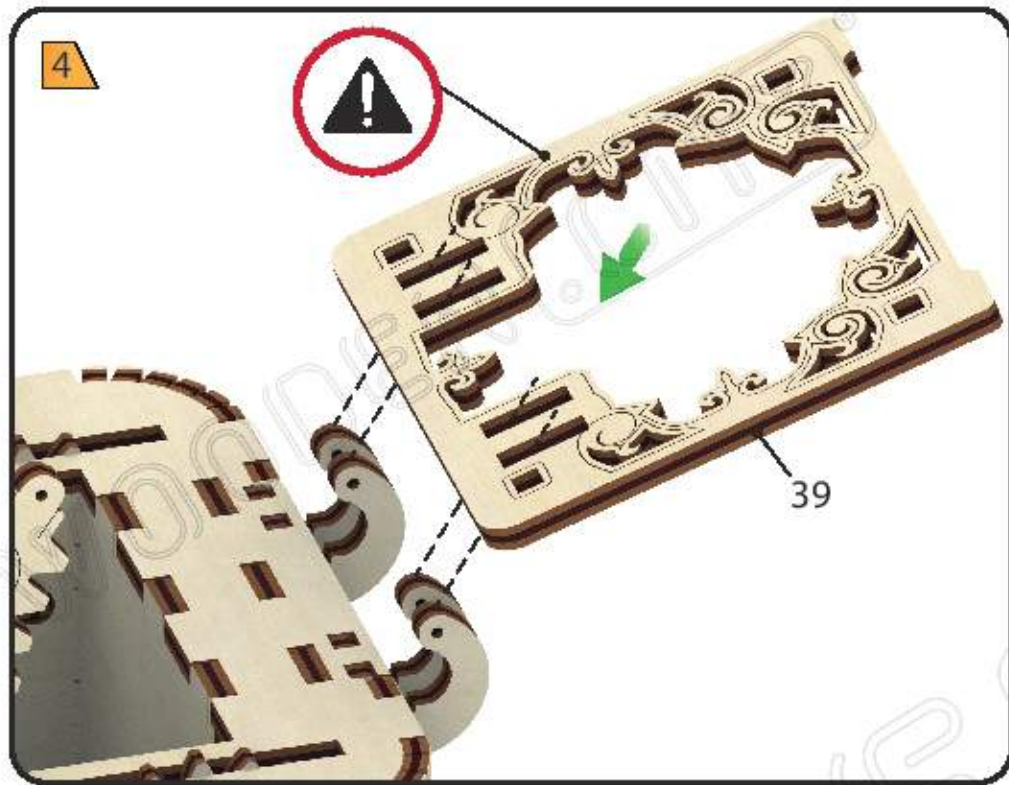

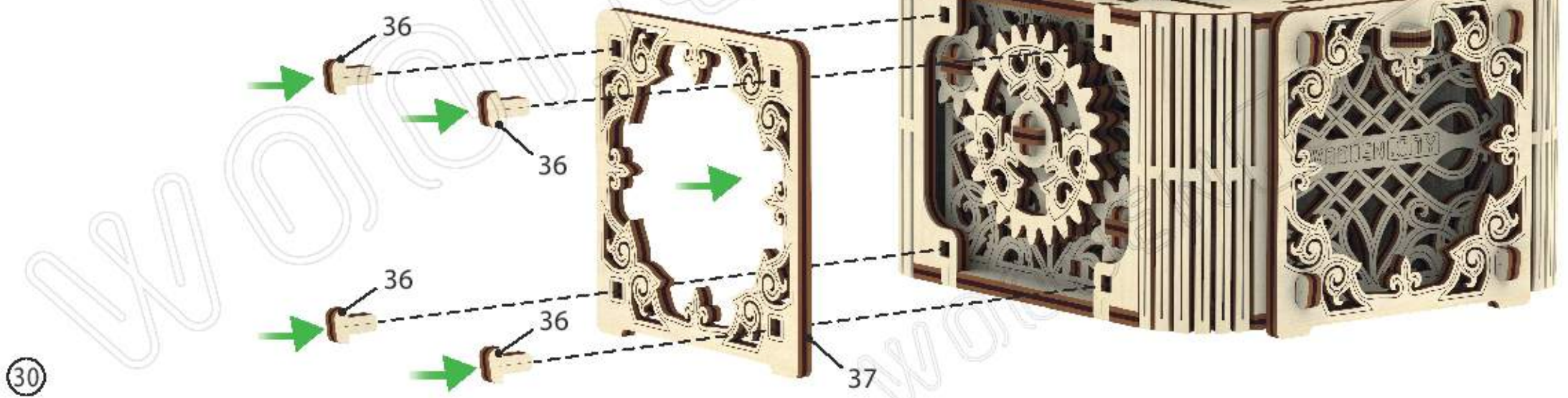
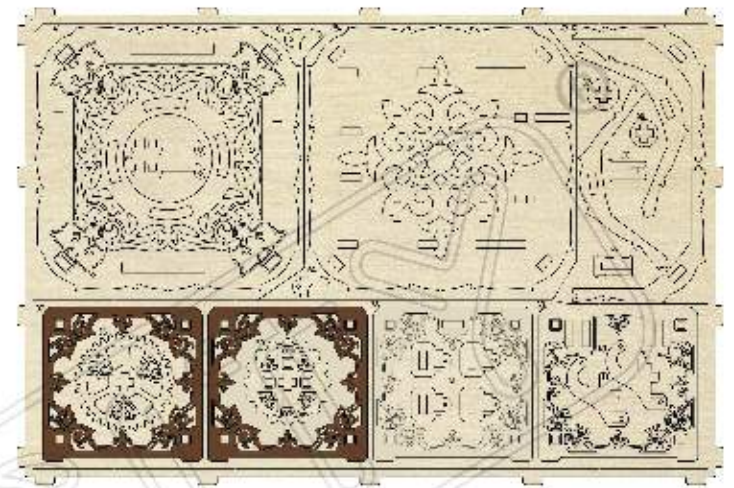
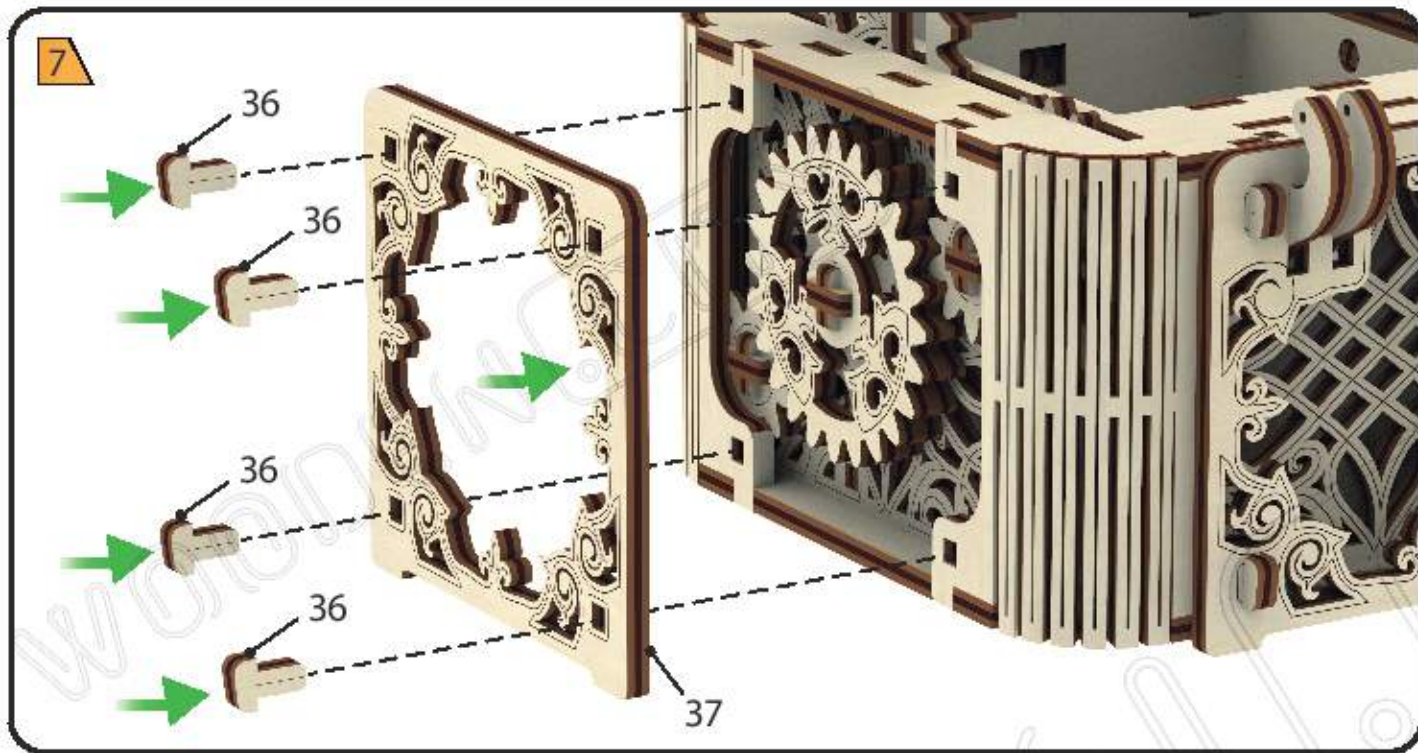

9

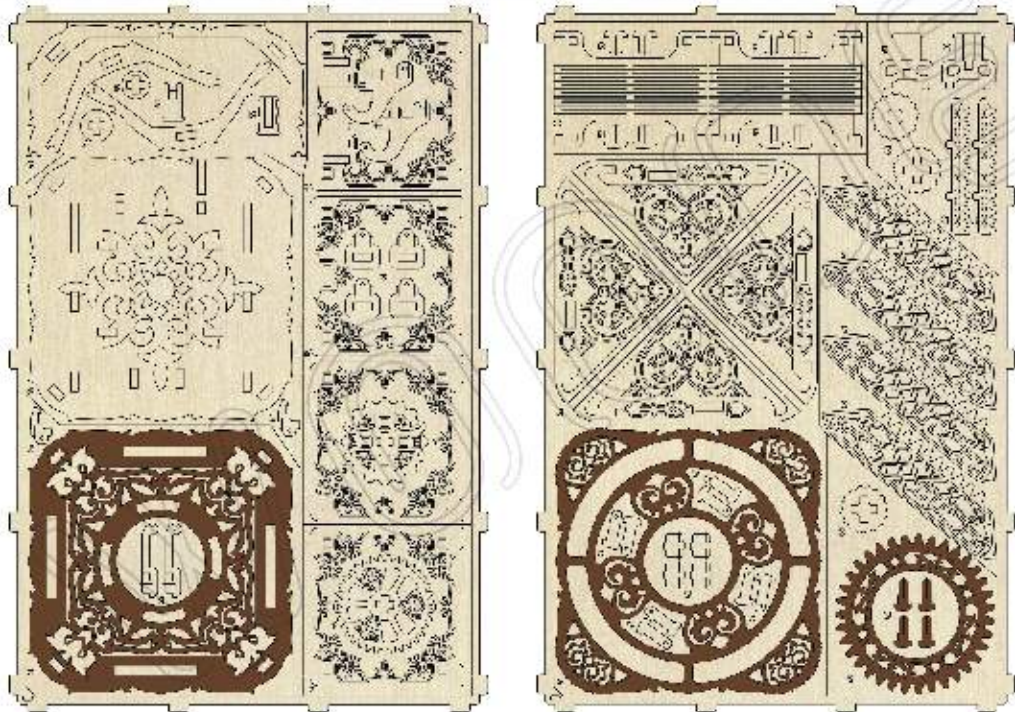
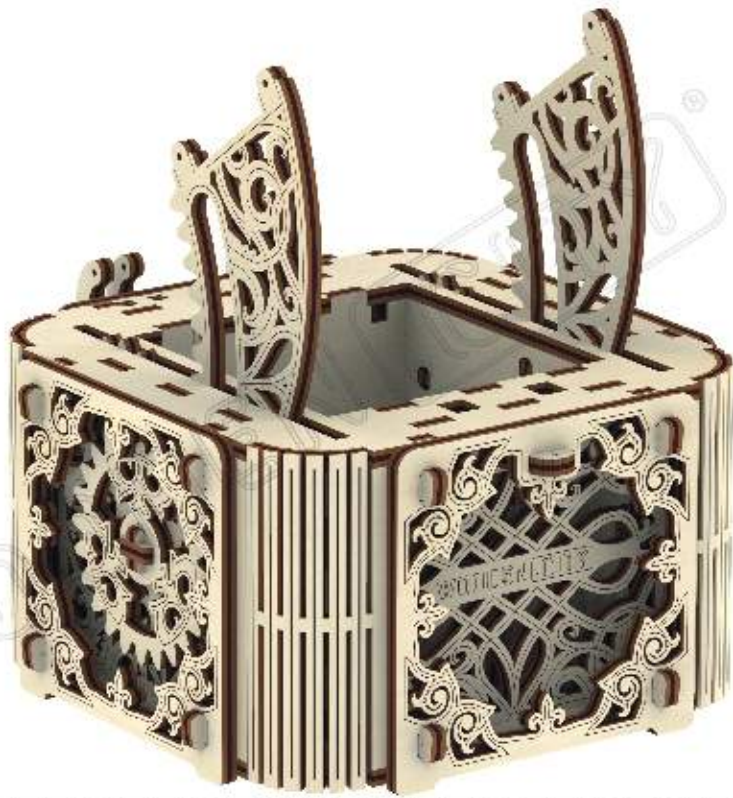

1

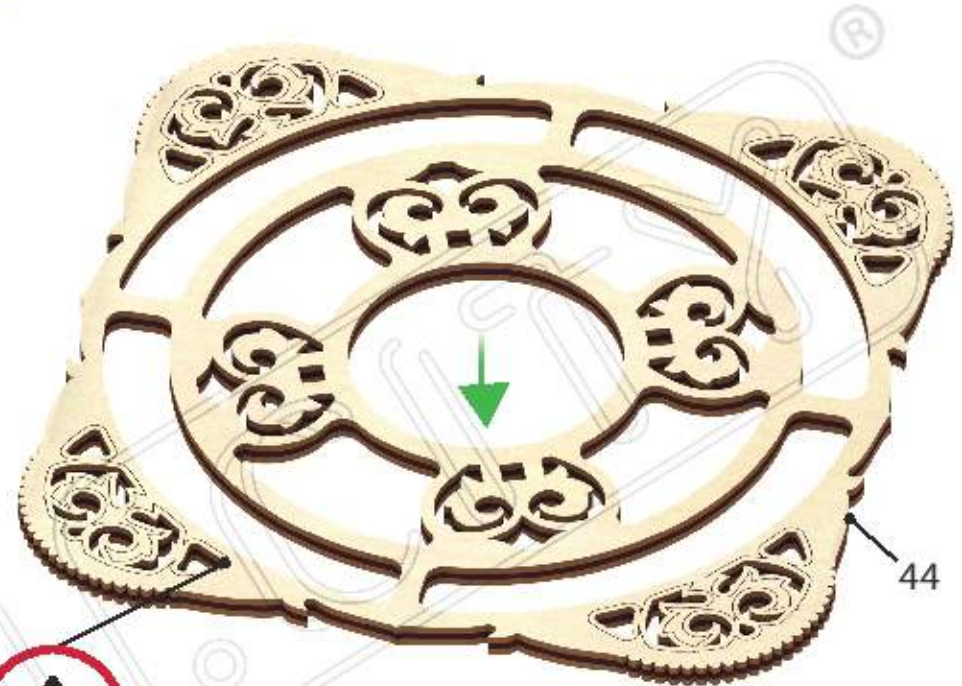

44



41

2



45



3

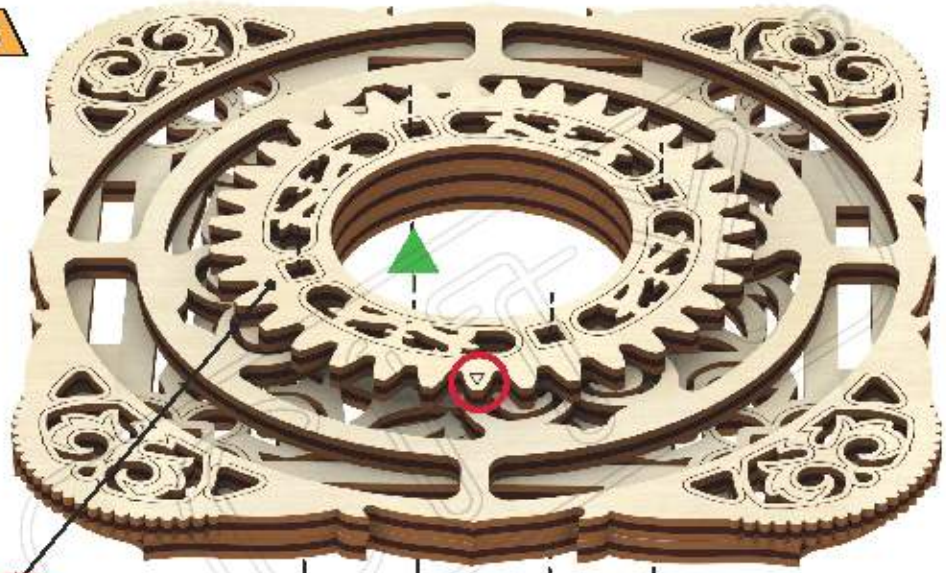

46

46

46

46

4

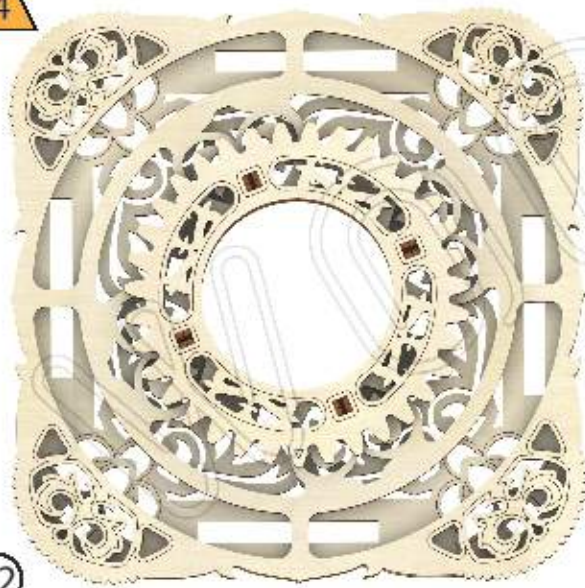

5



6



32



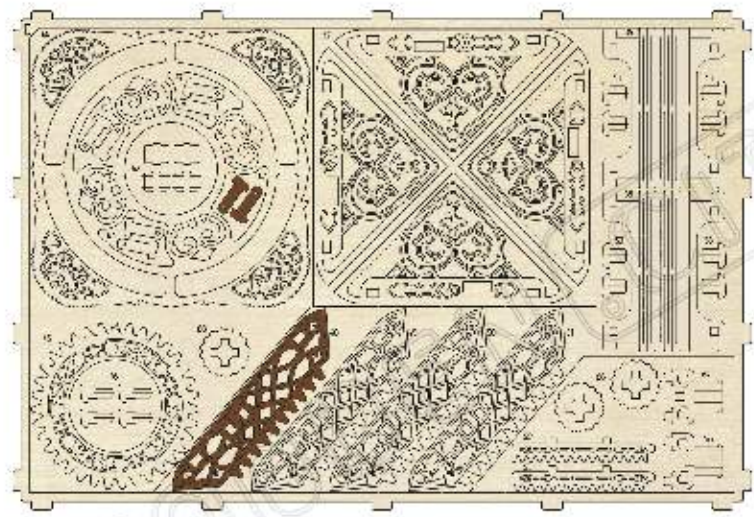

2

48

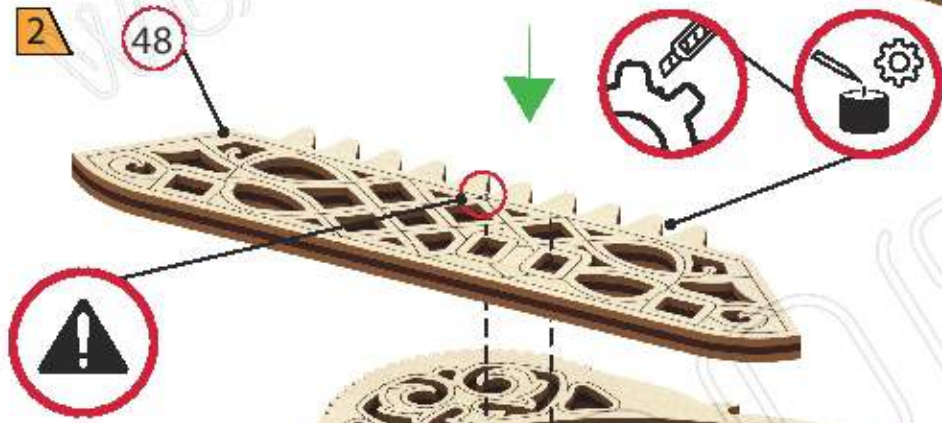

47

47

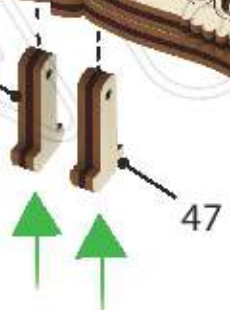

3

4x13 mm

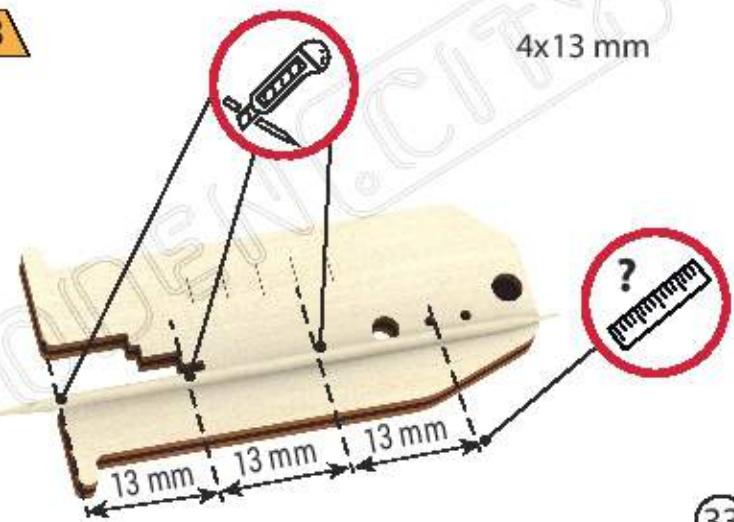

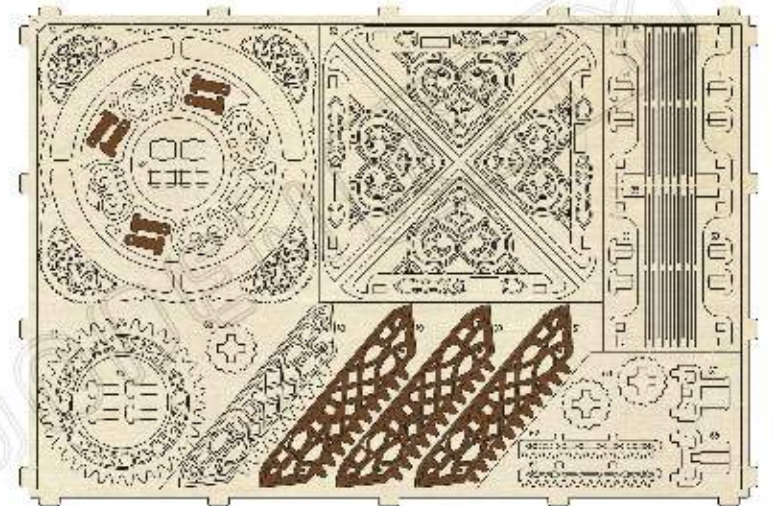
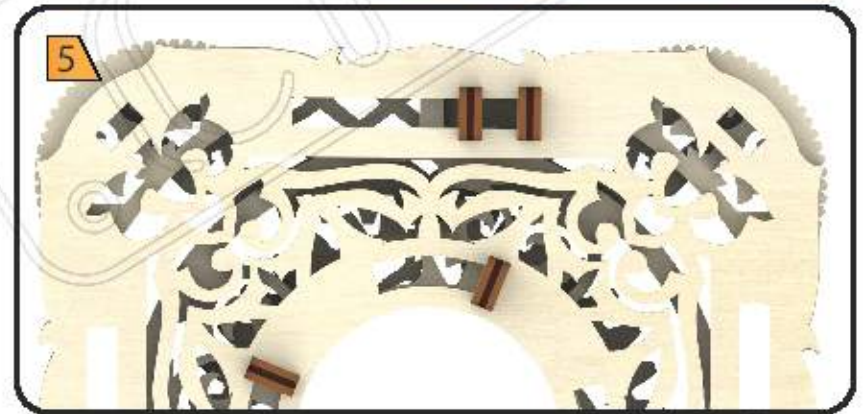
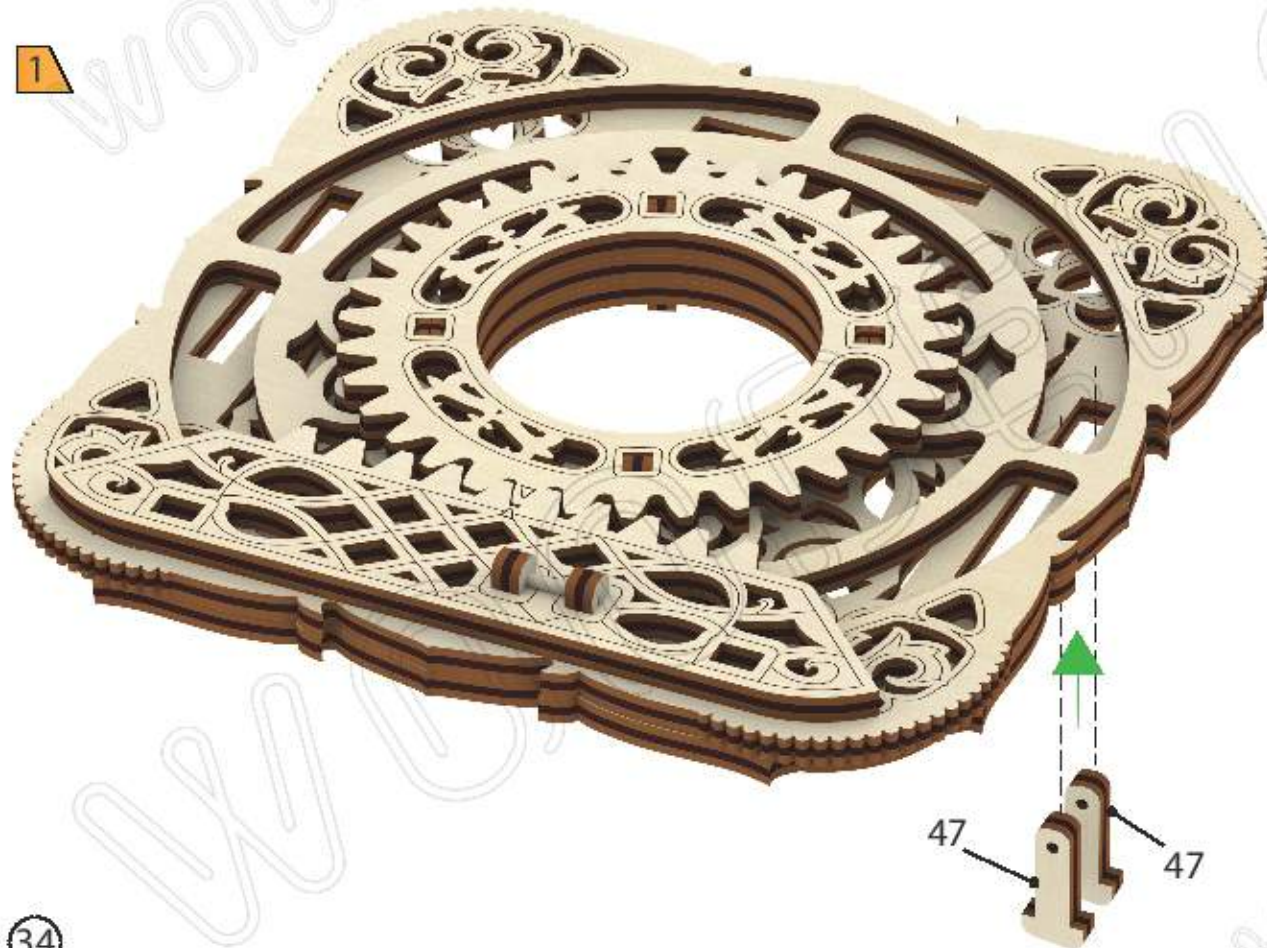

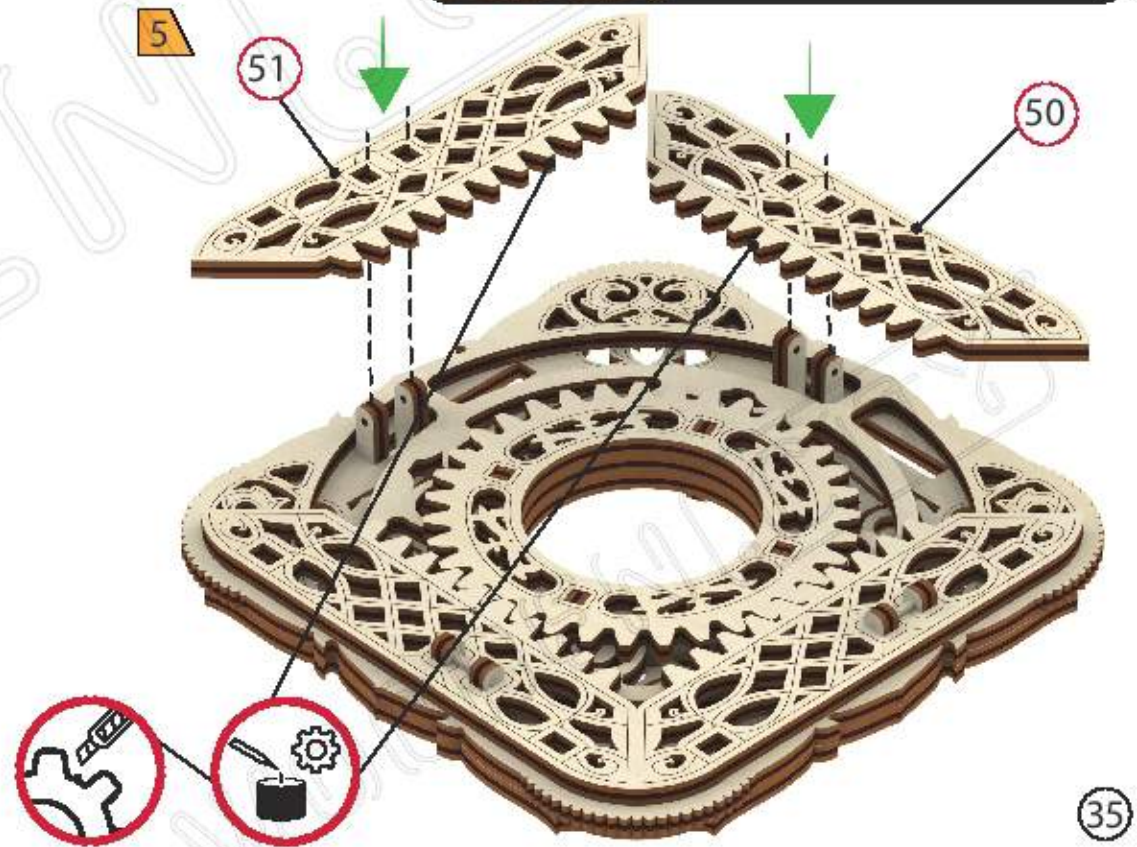
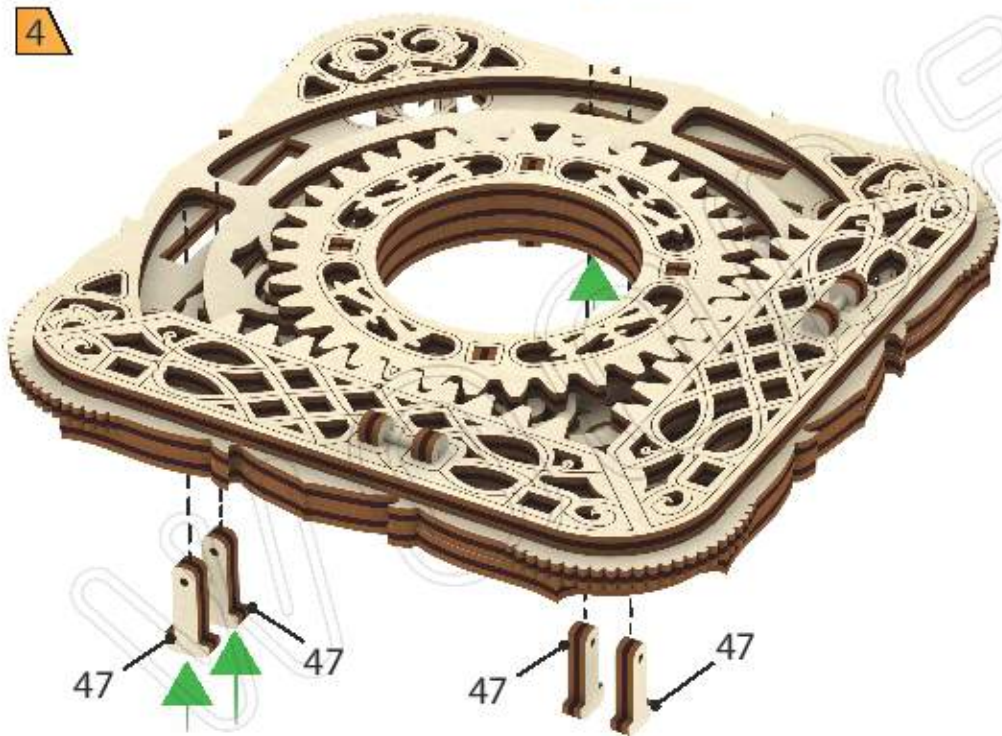
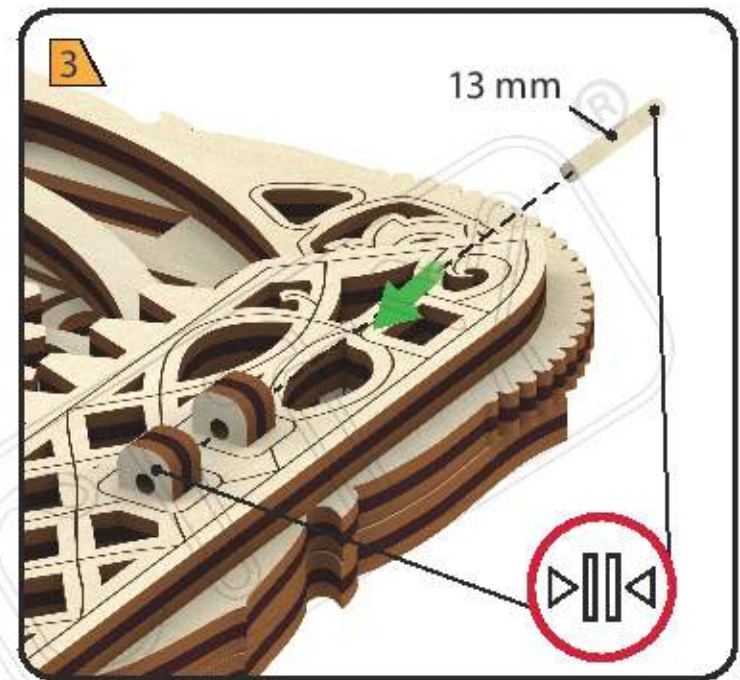
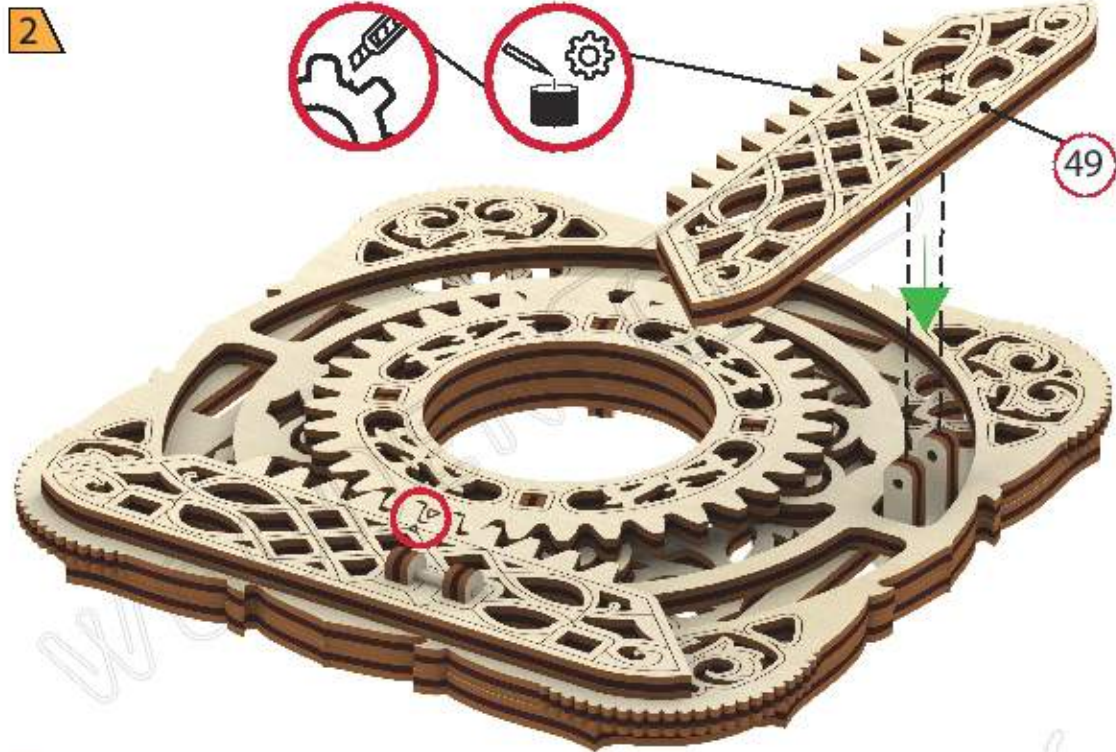

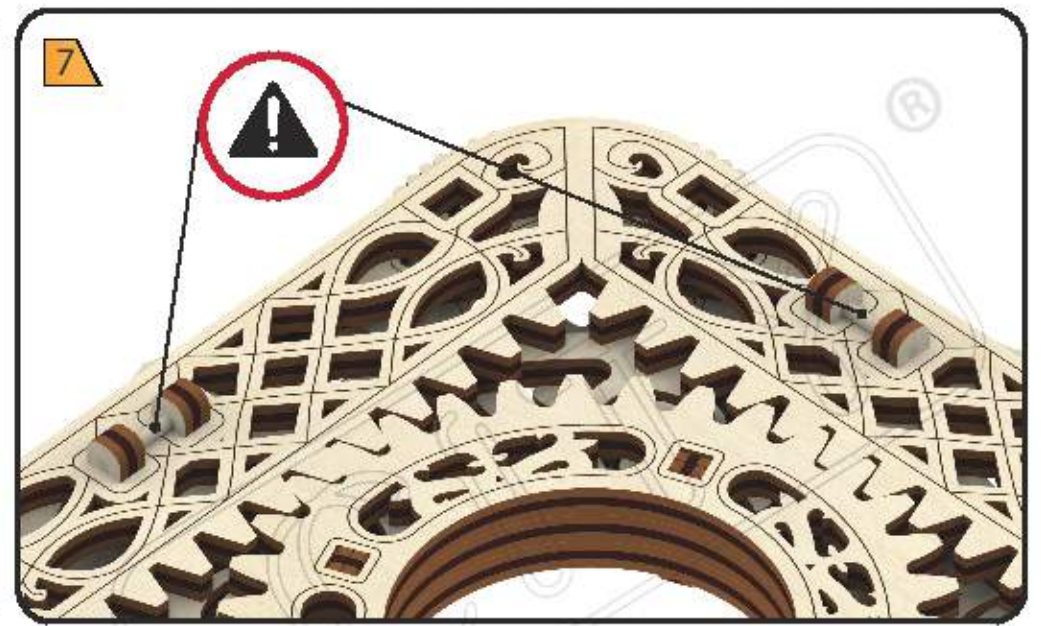
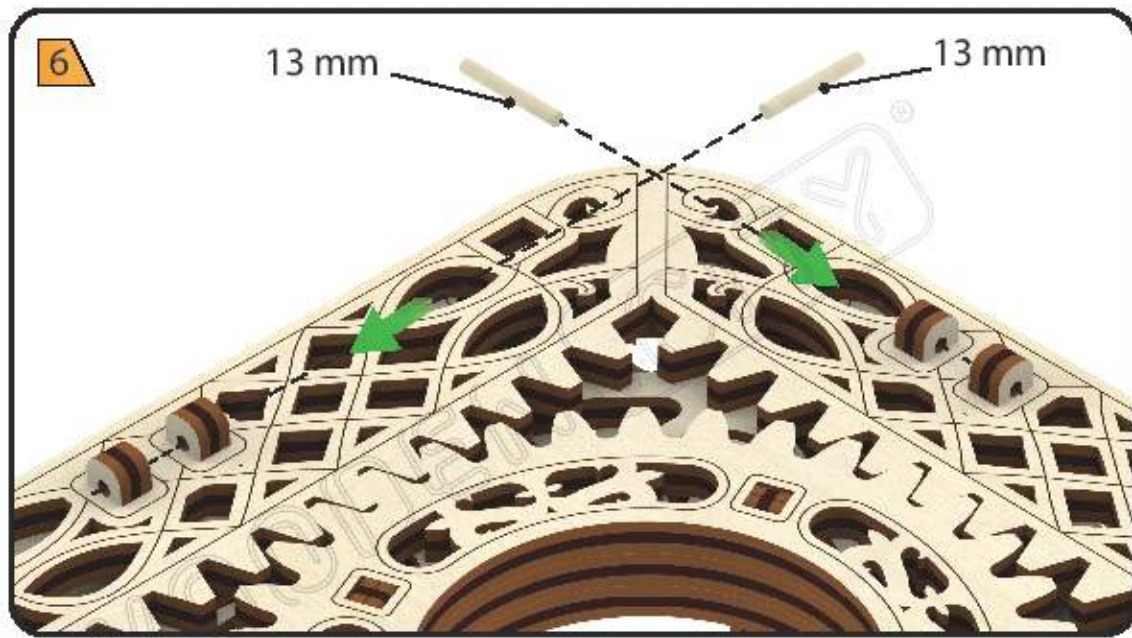

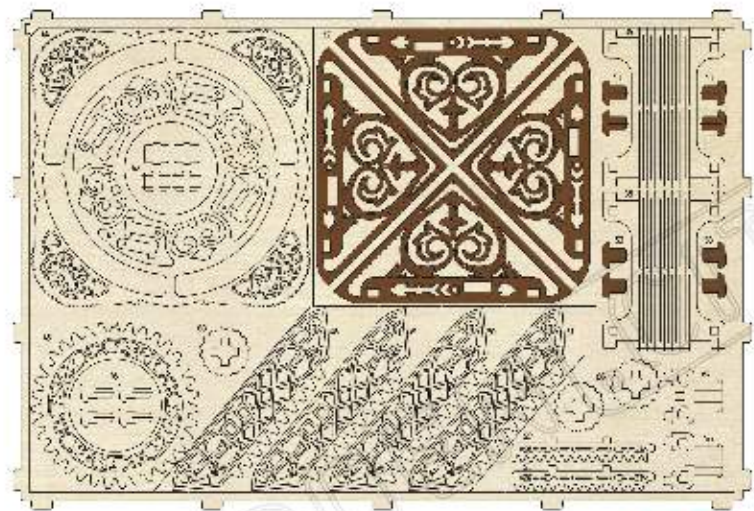

1



2

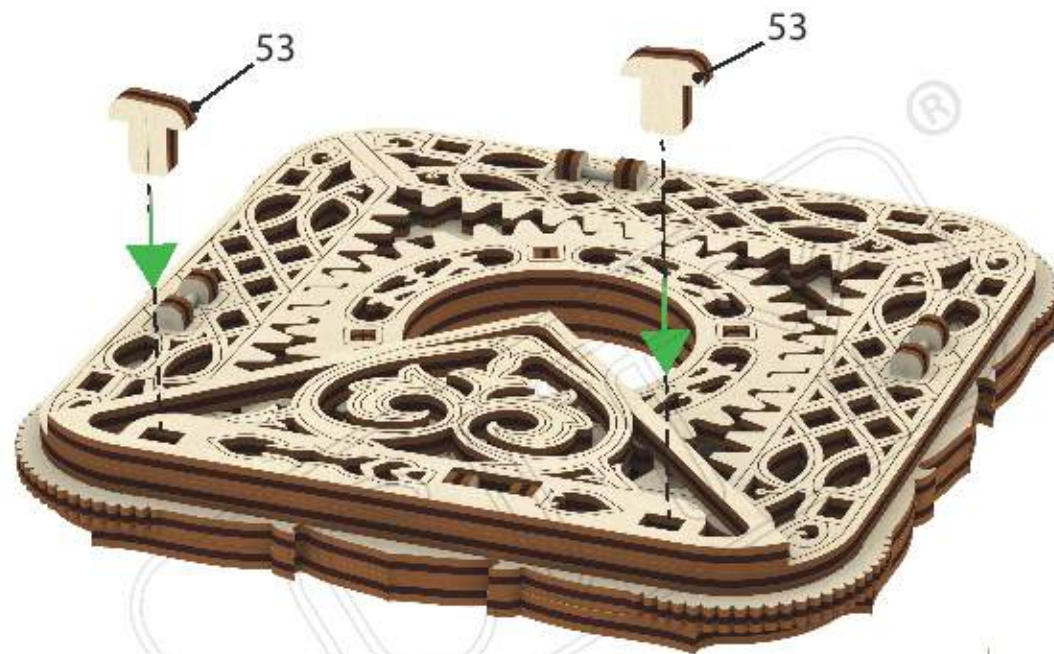

3

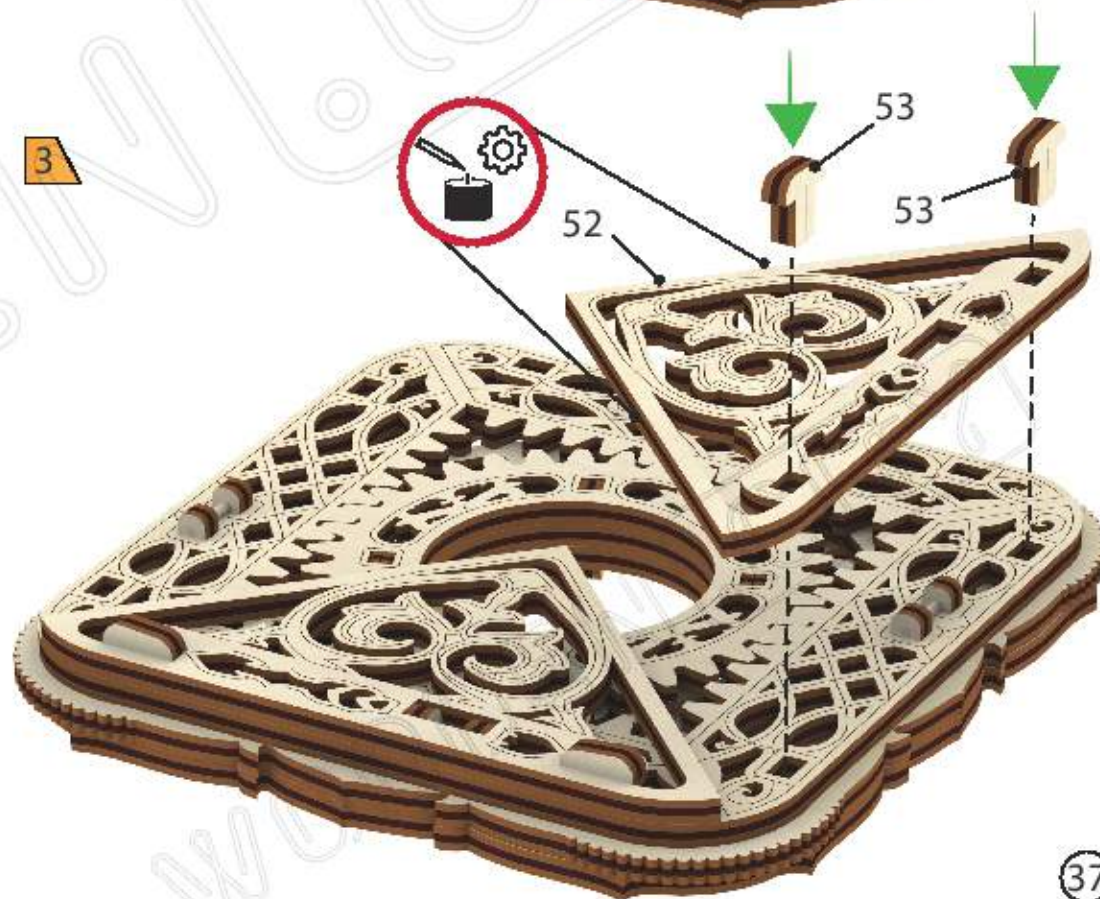

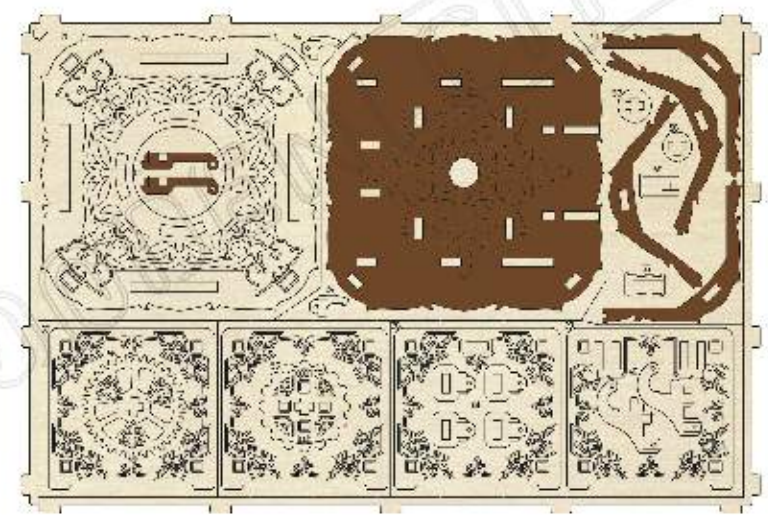
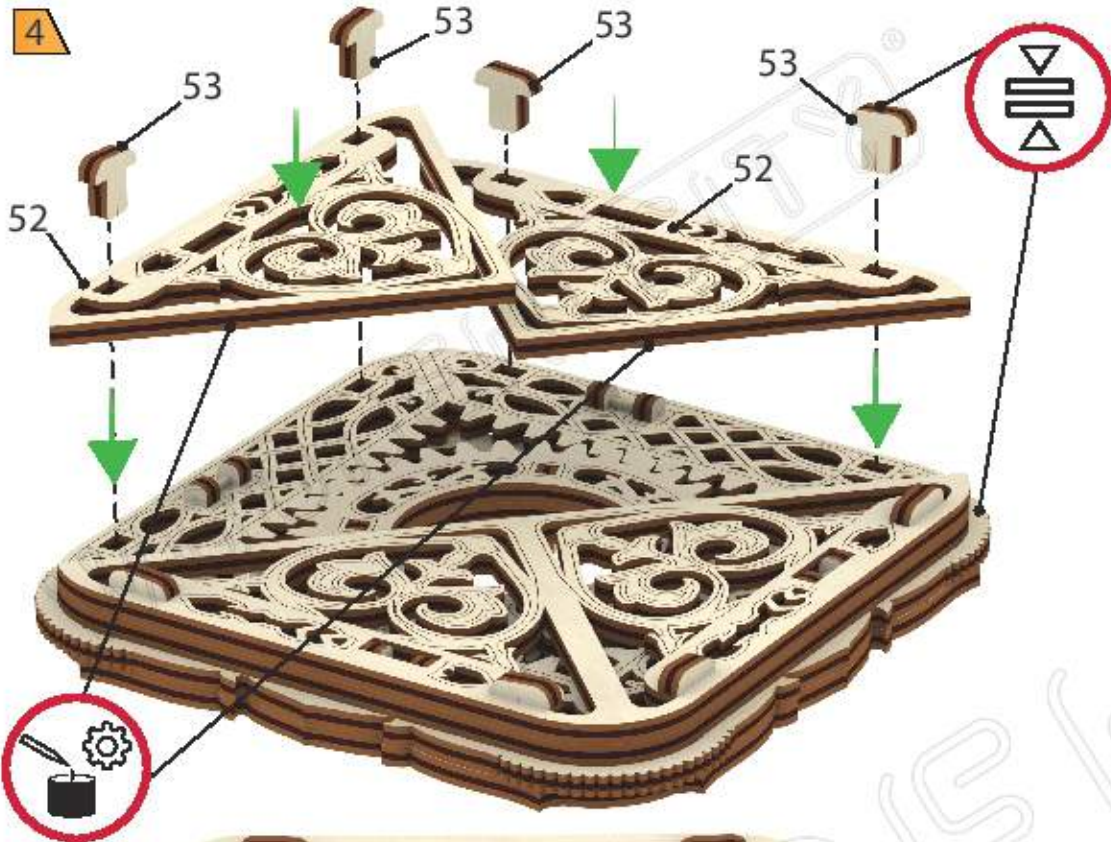

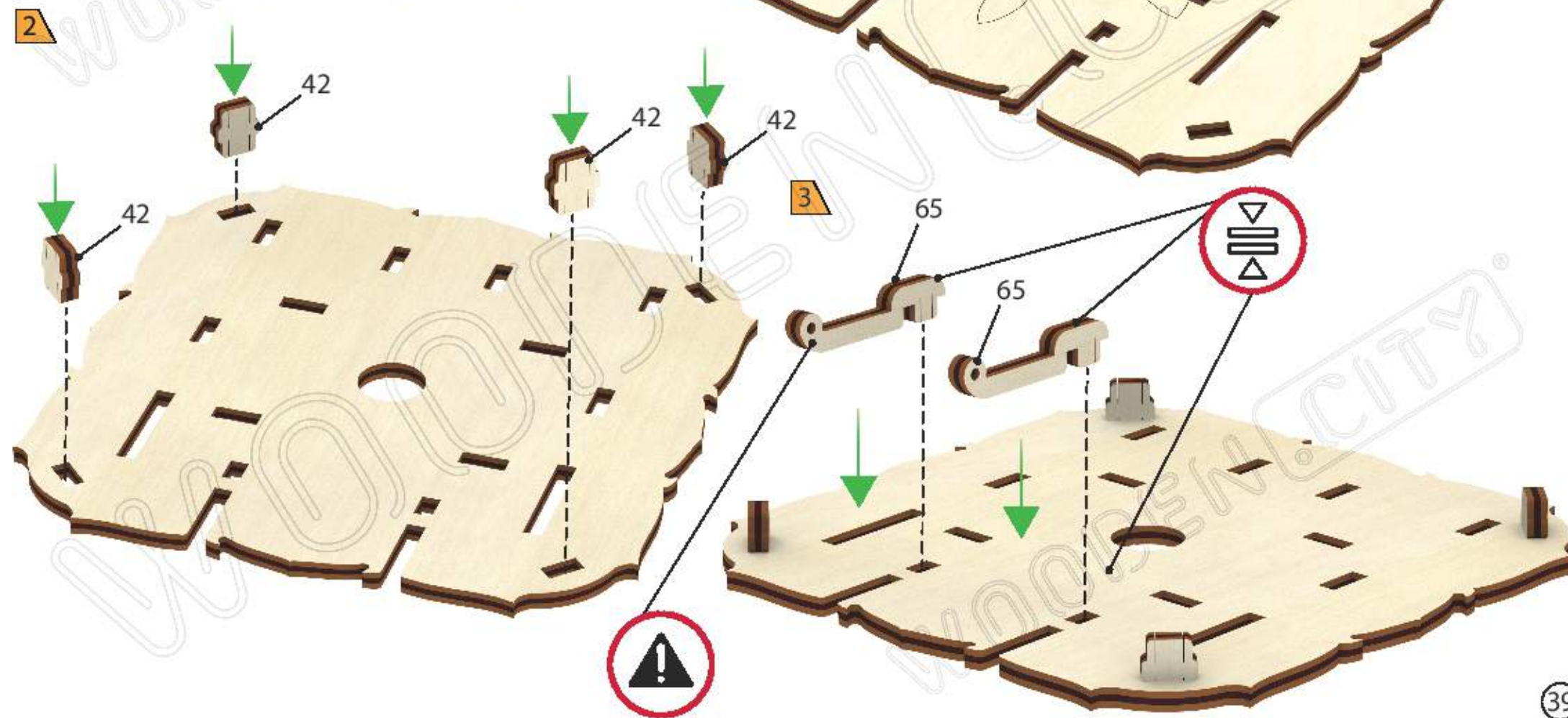
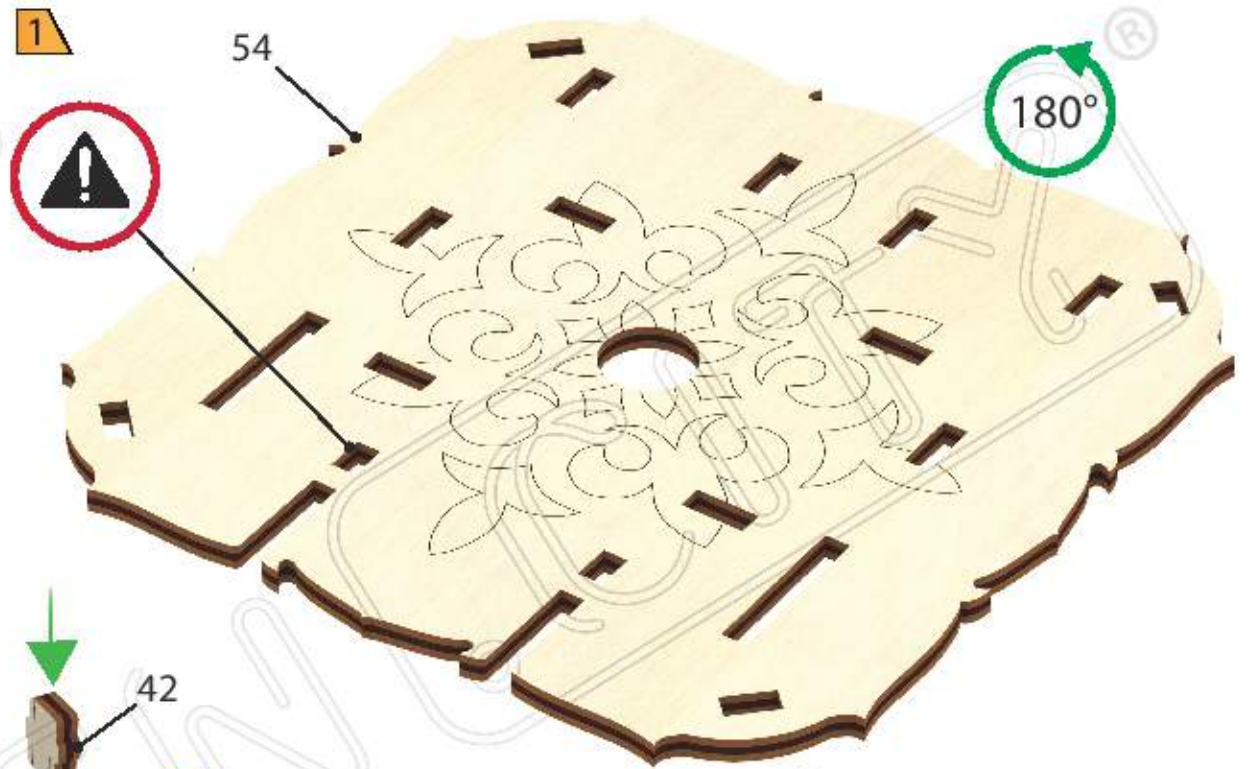
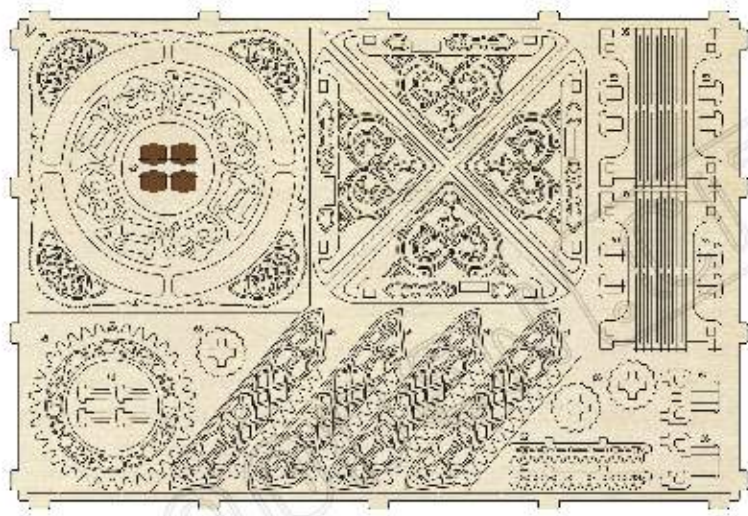

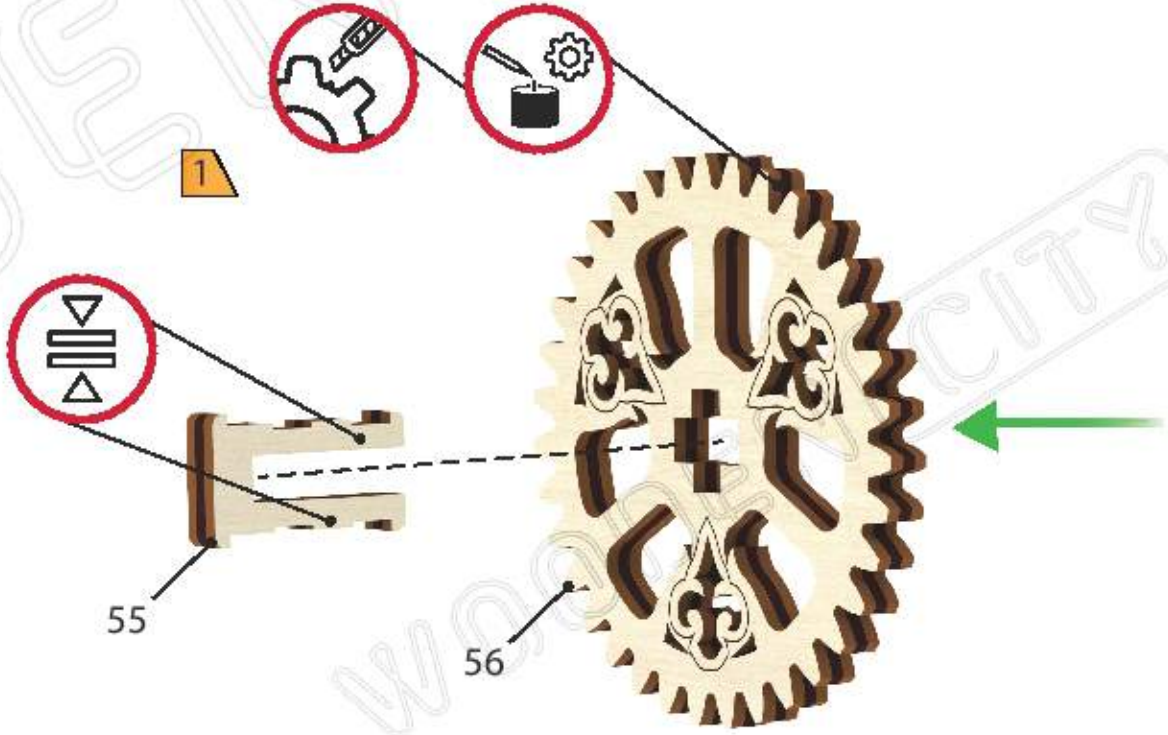
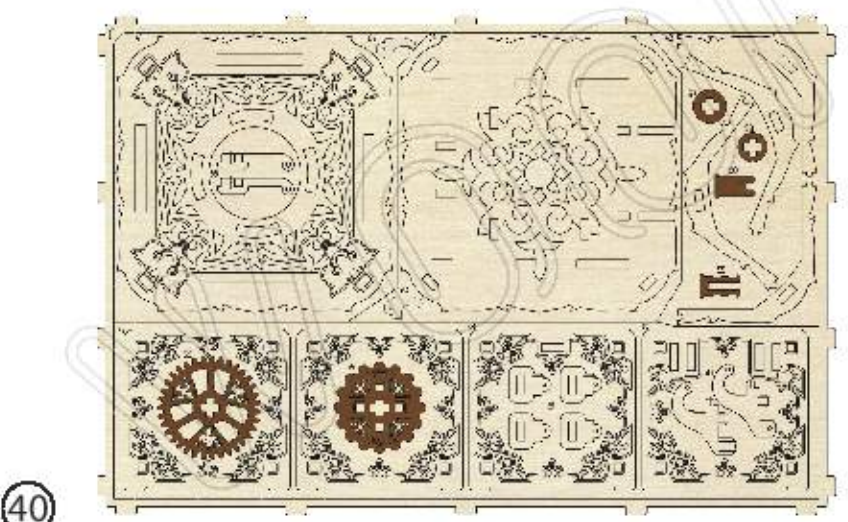
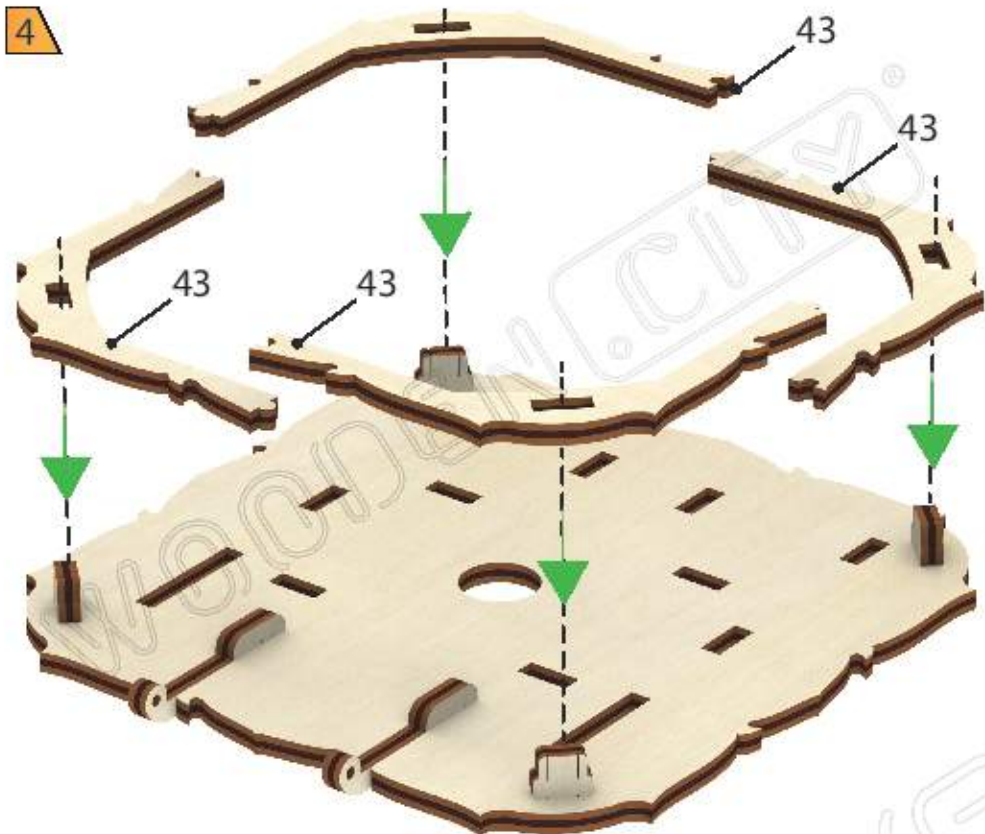



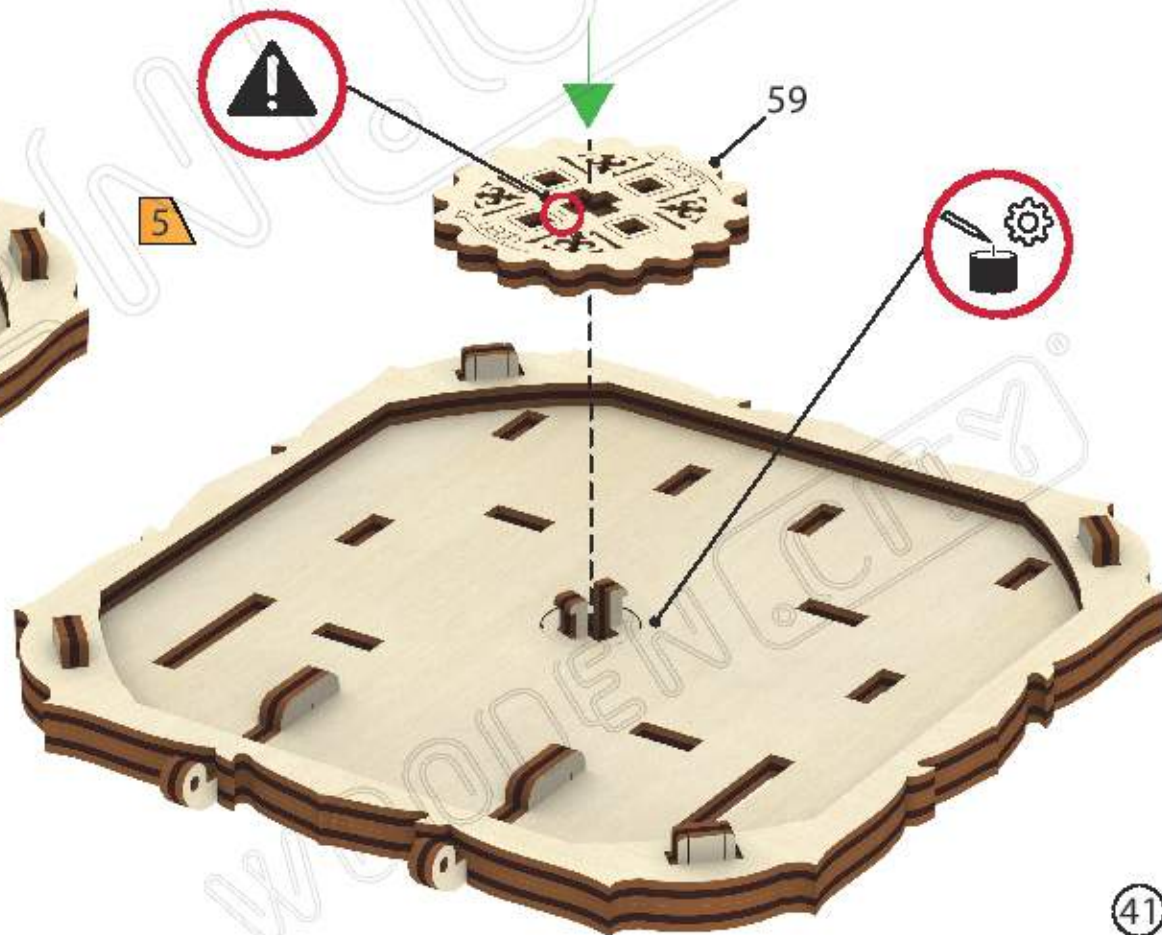
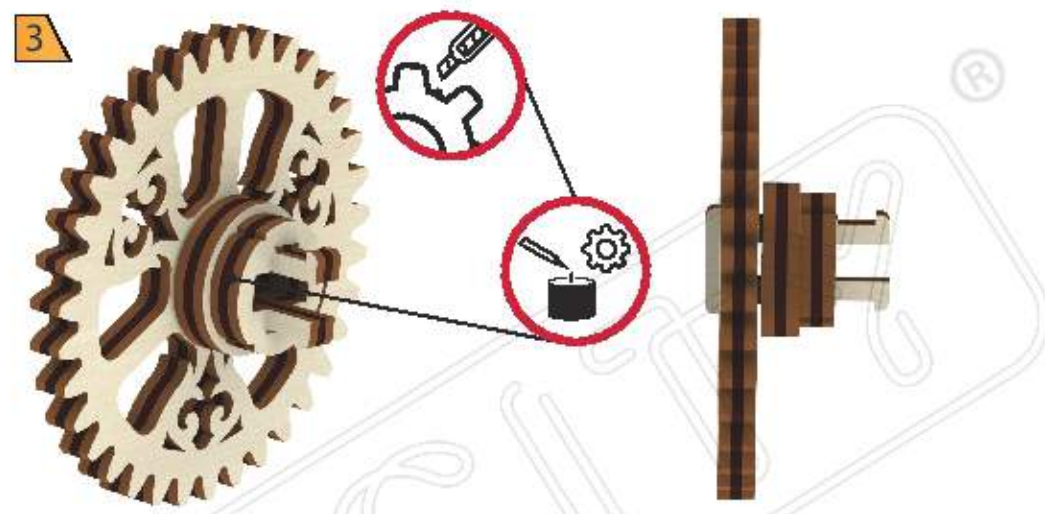
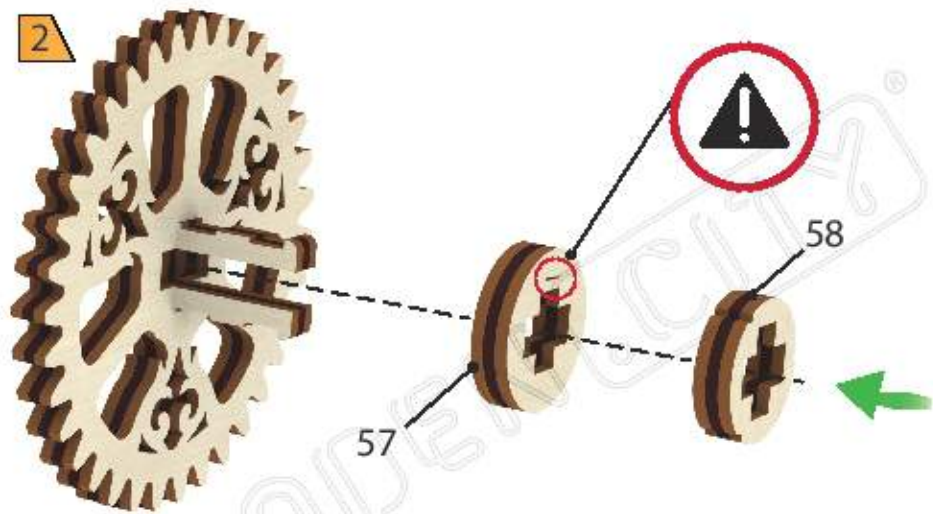

6

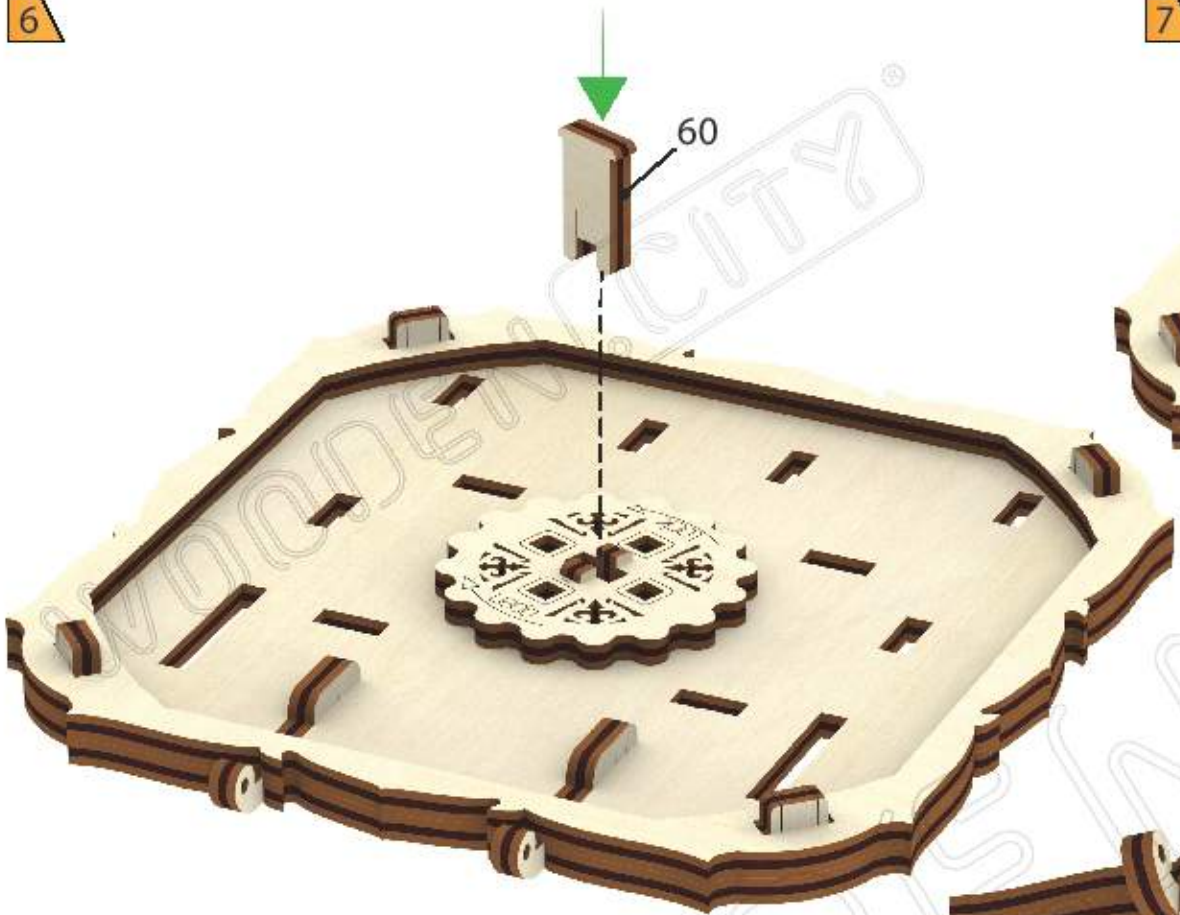

7



1

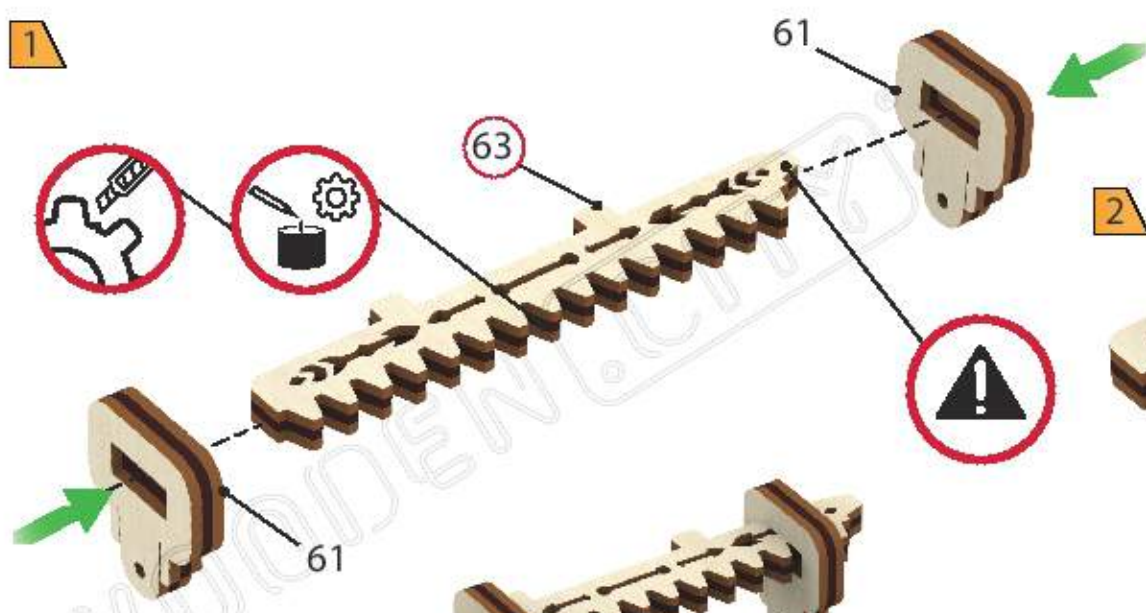

2



3

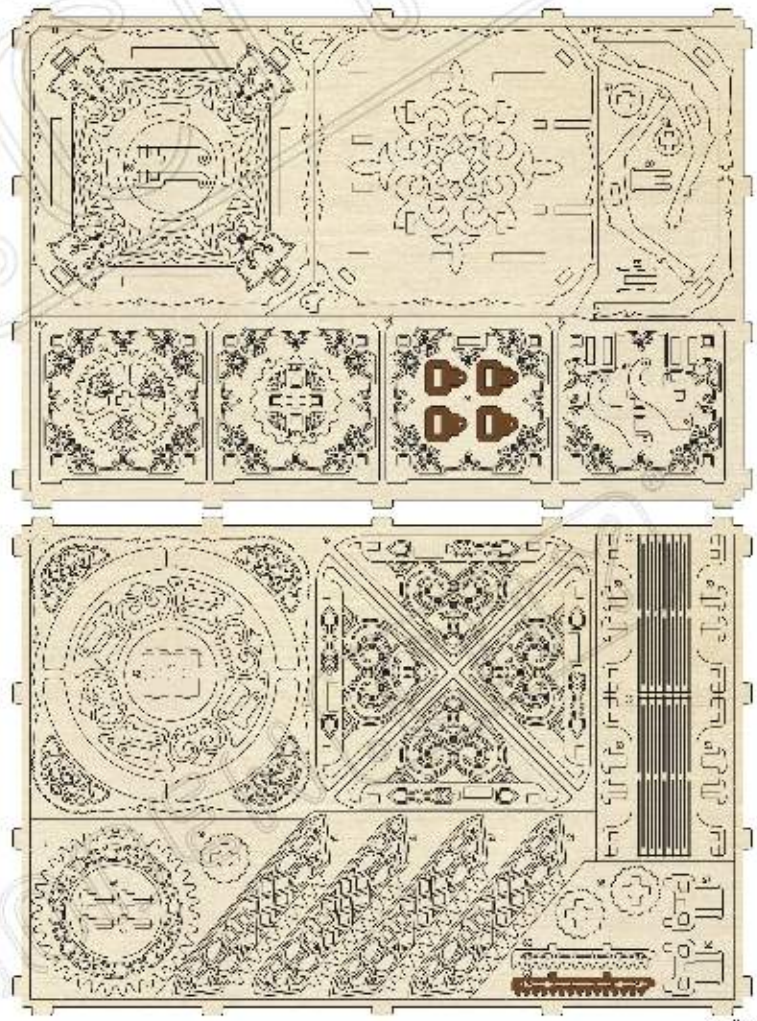
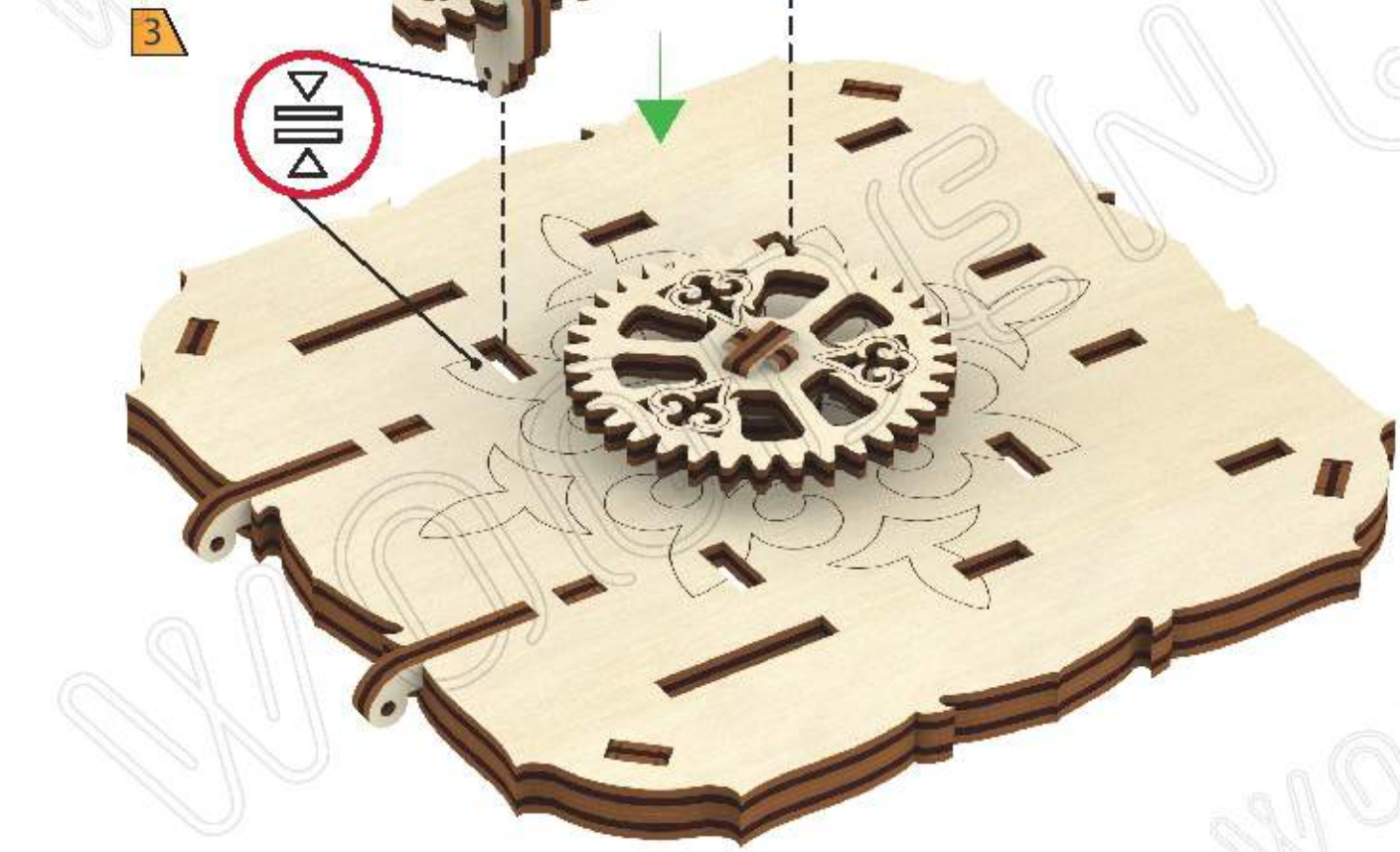

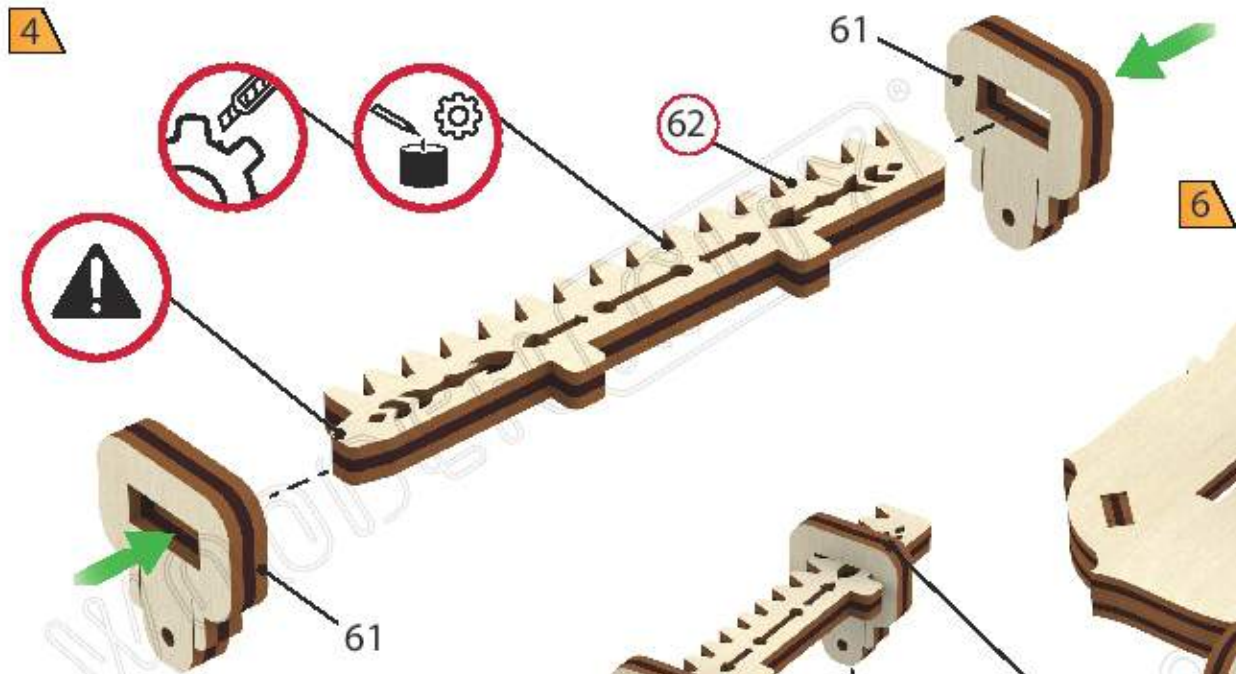

**6**



**5**

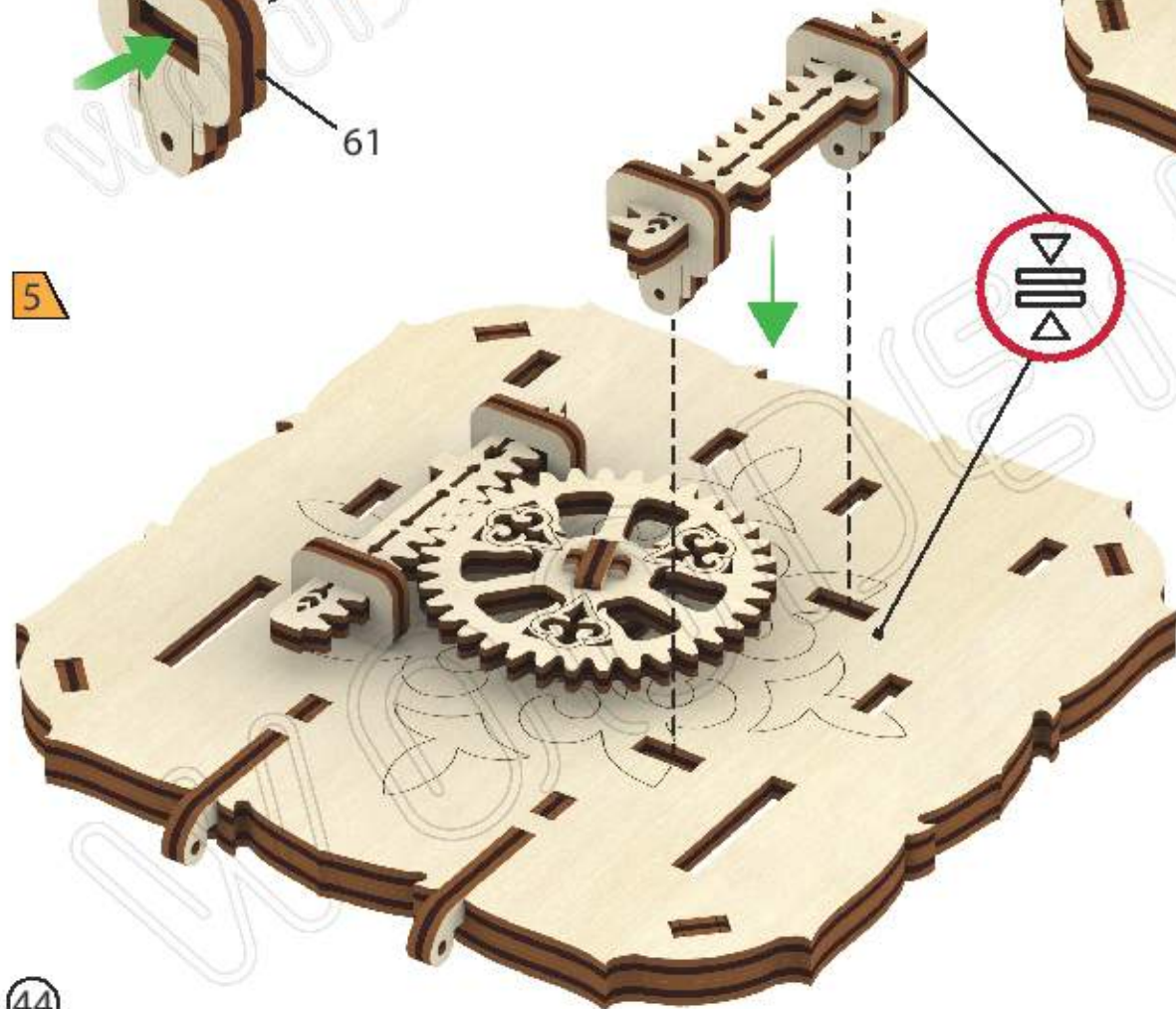

**44**

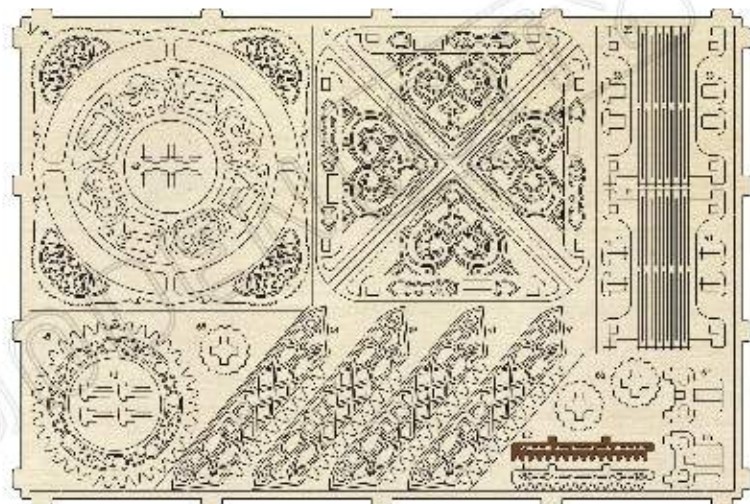

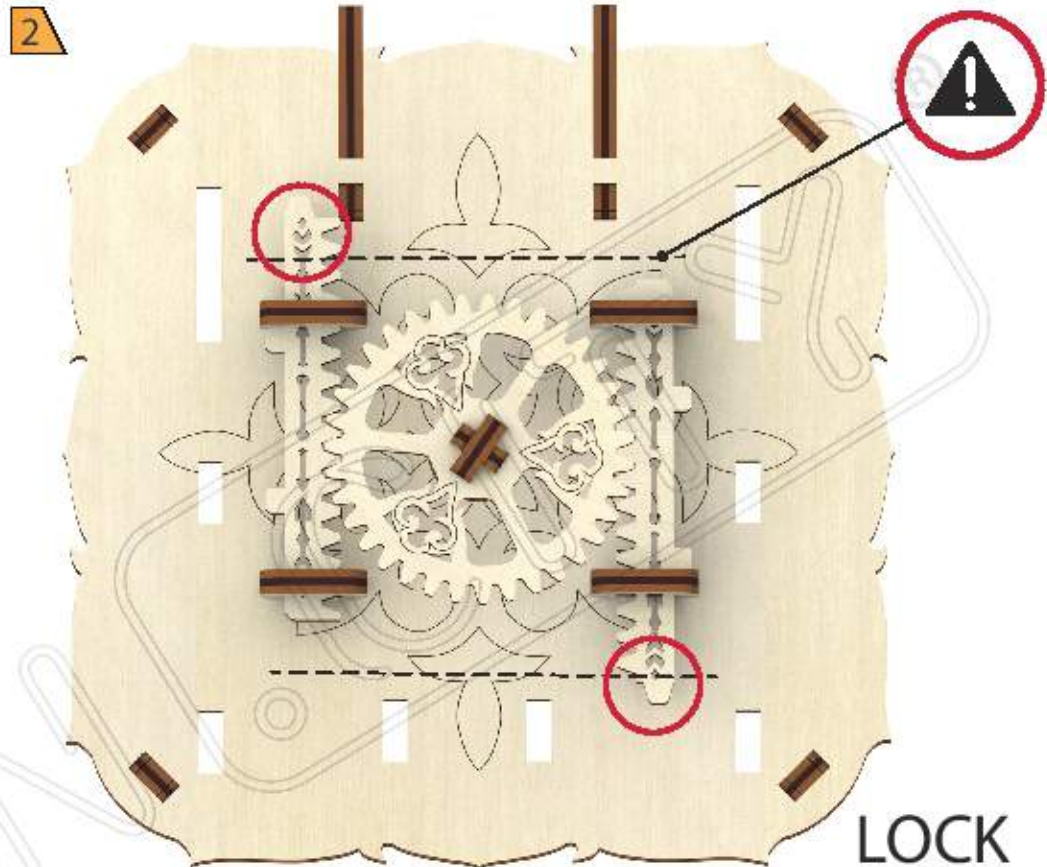
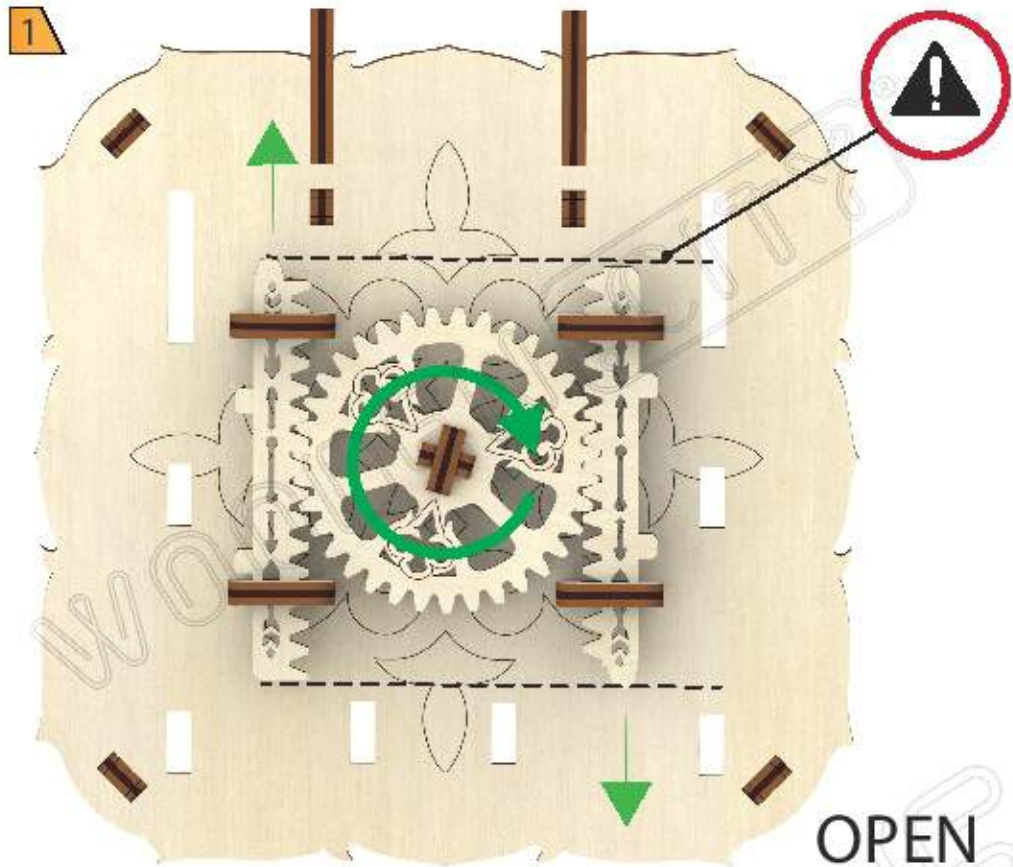

OPEN

LOCK

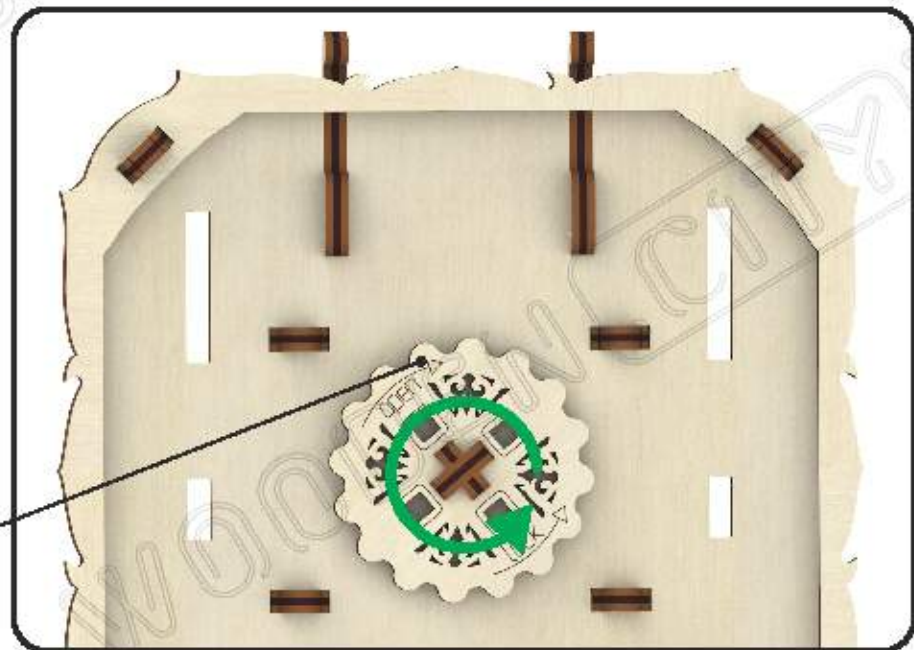
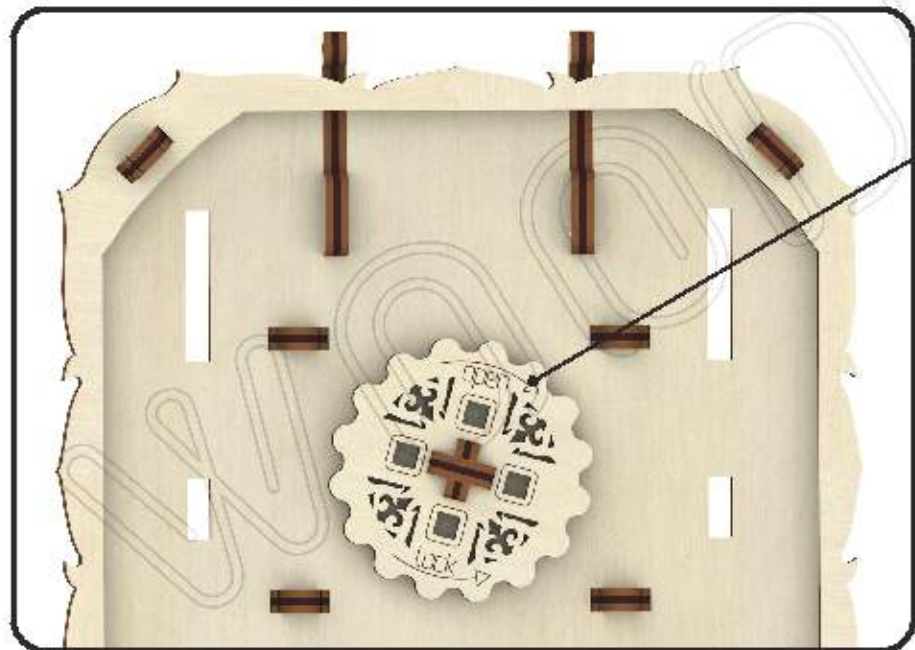

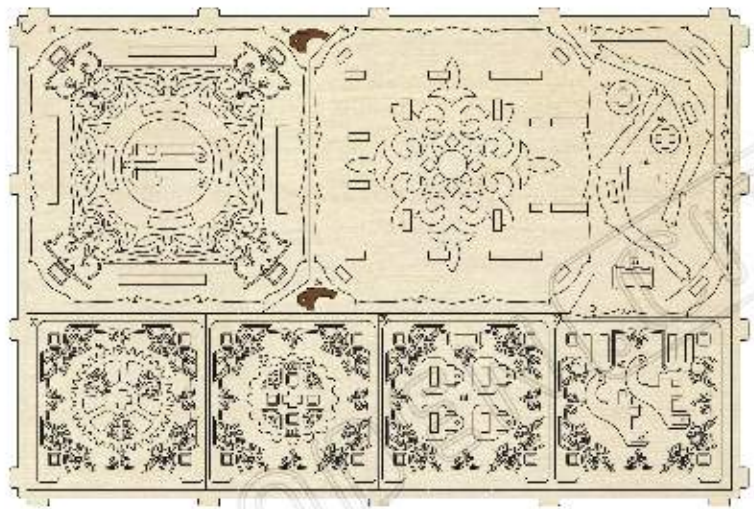

1

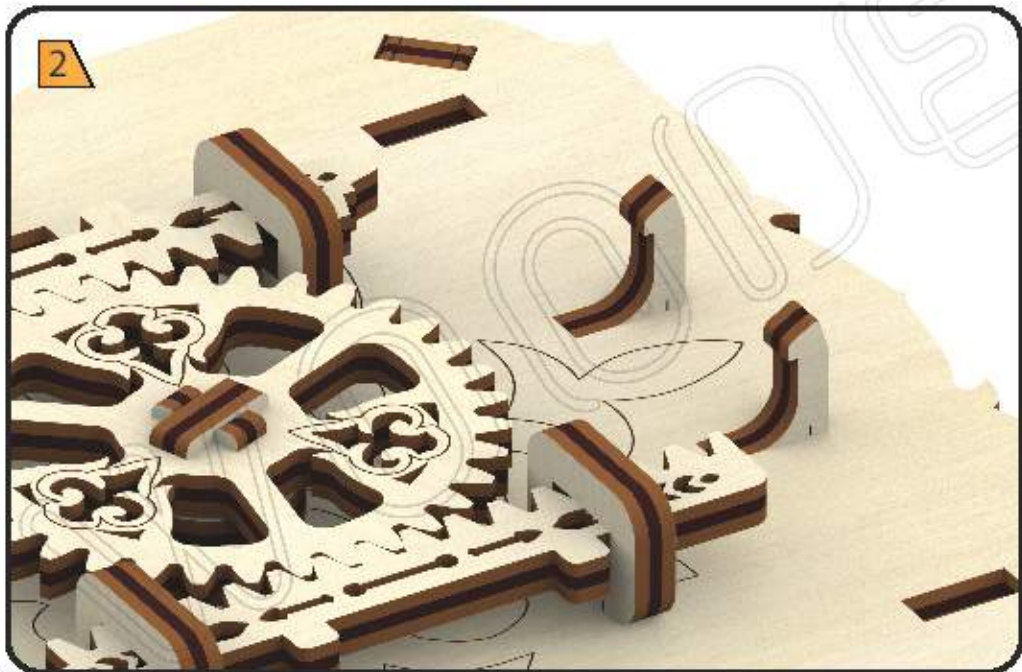
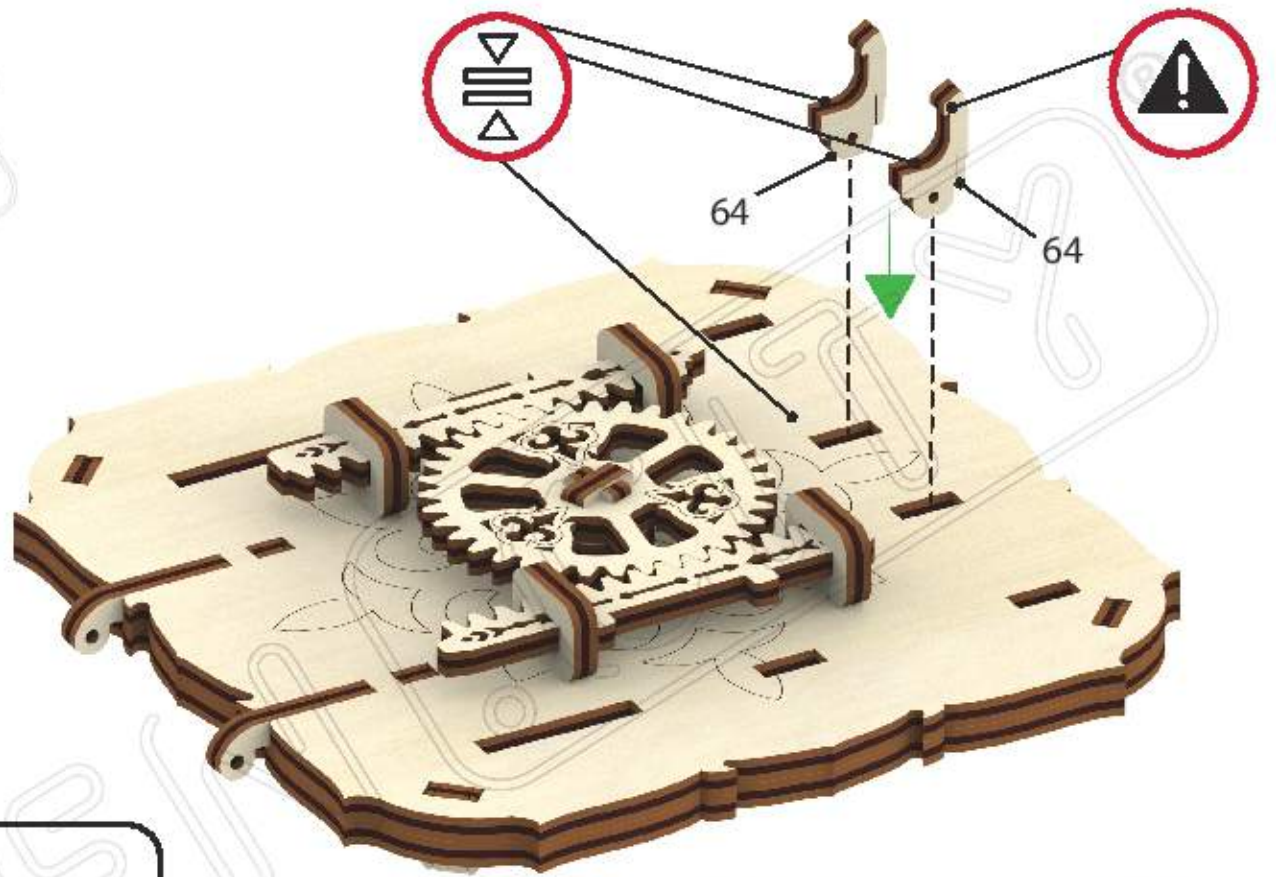

2

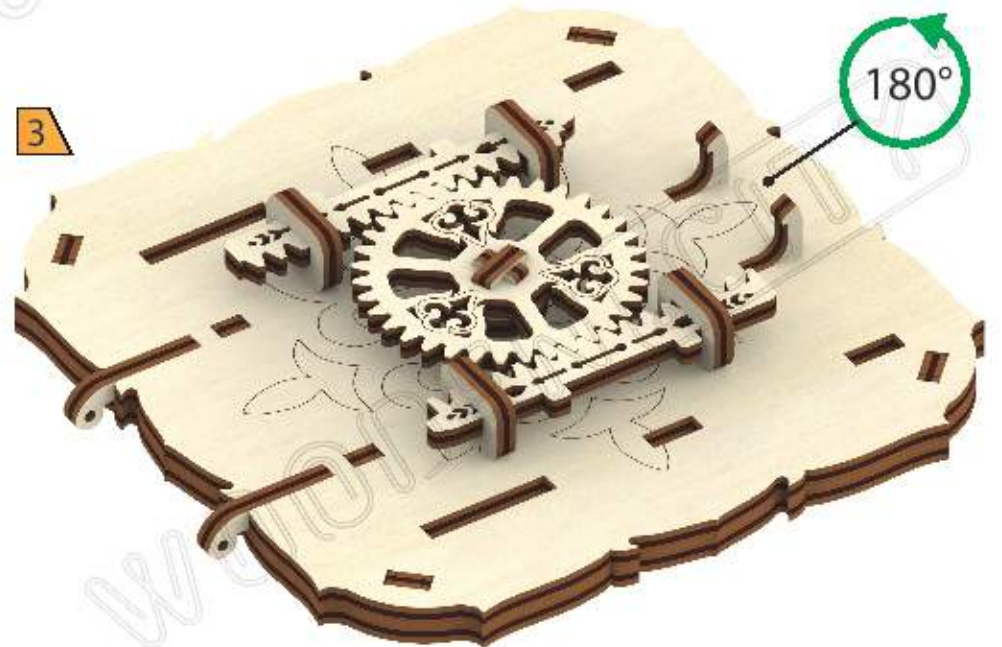

3

4

4x9 mm

6

9 mm

32 mm

5

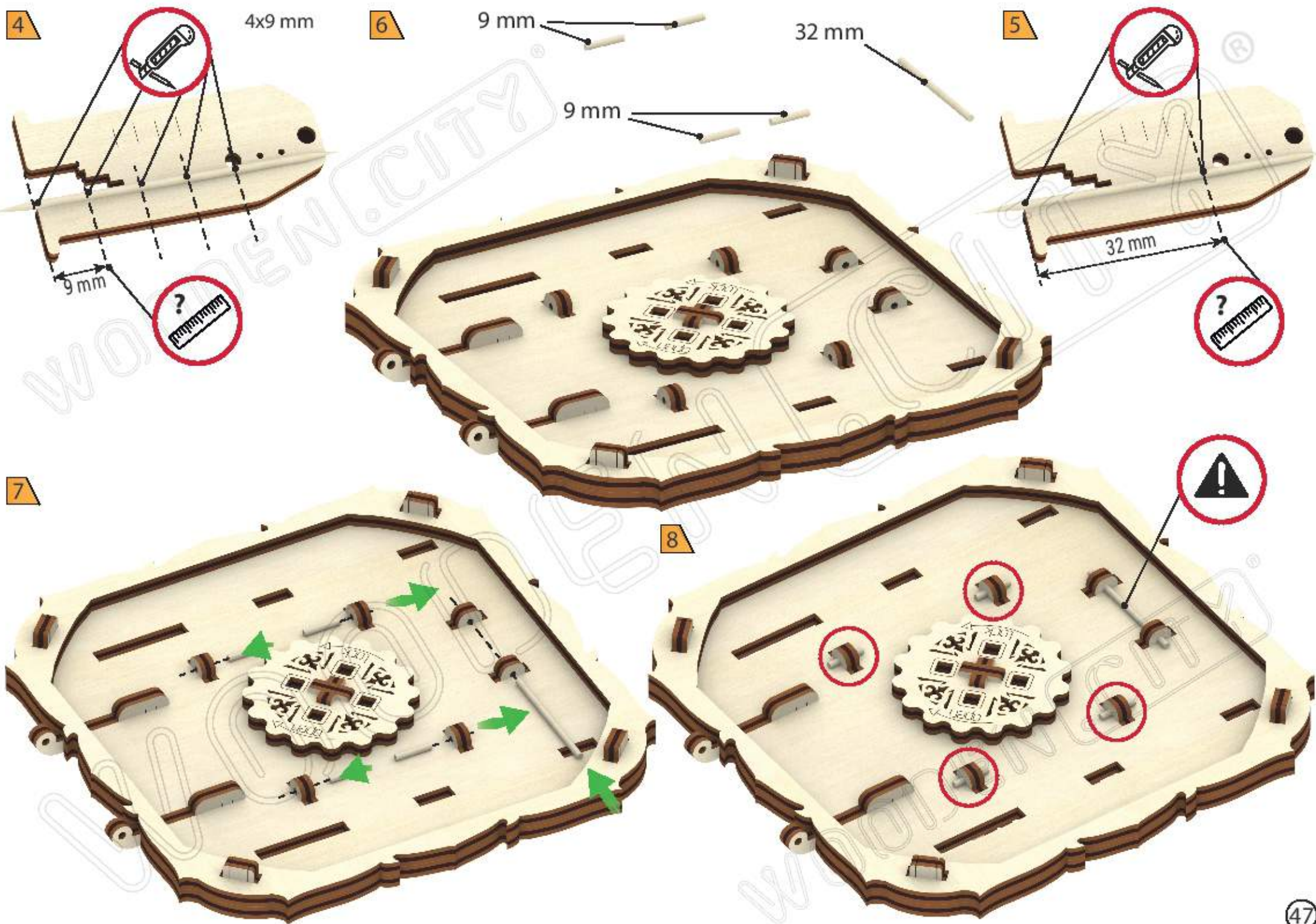

1

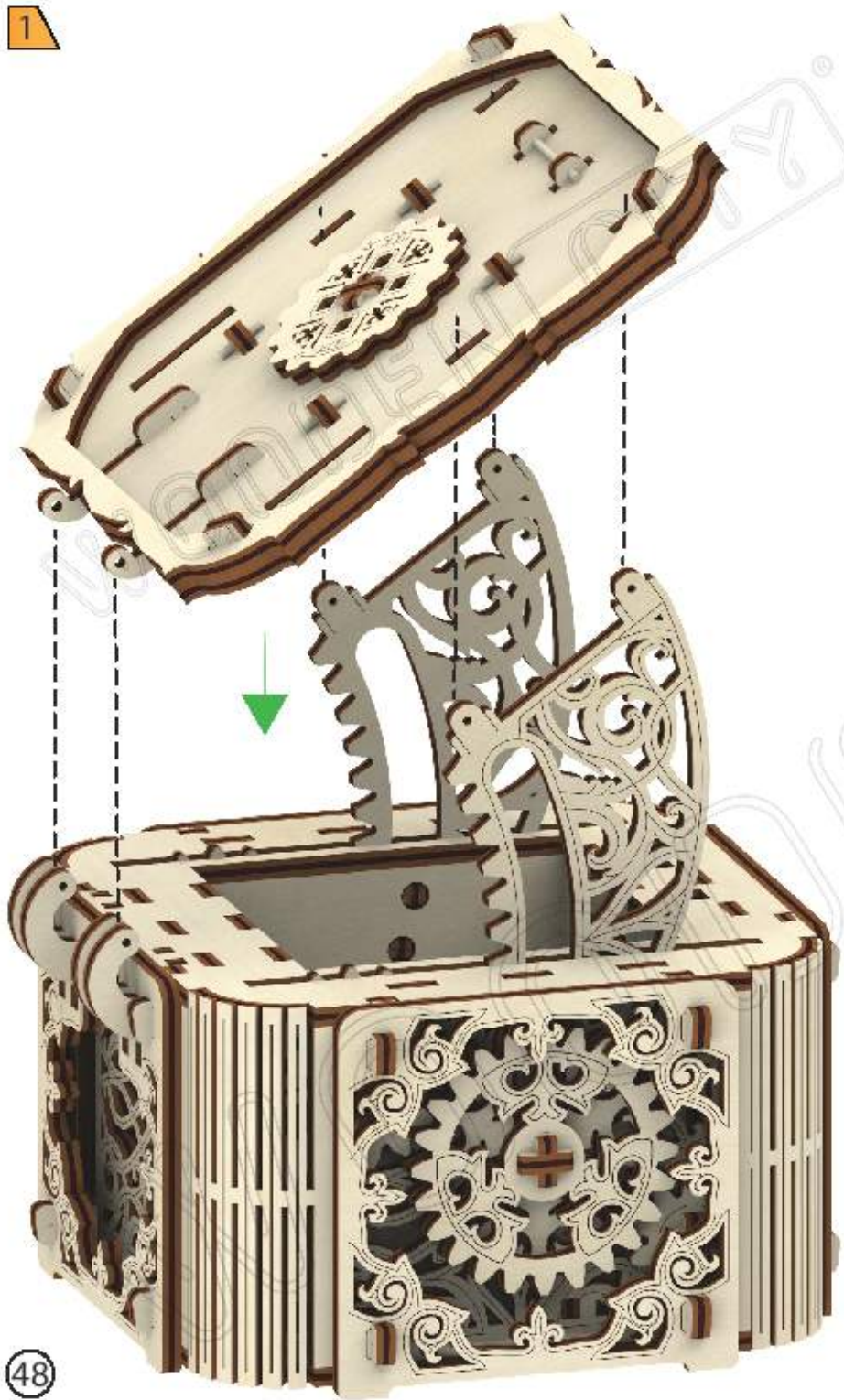

3

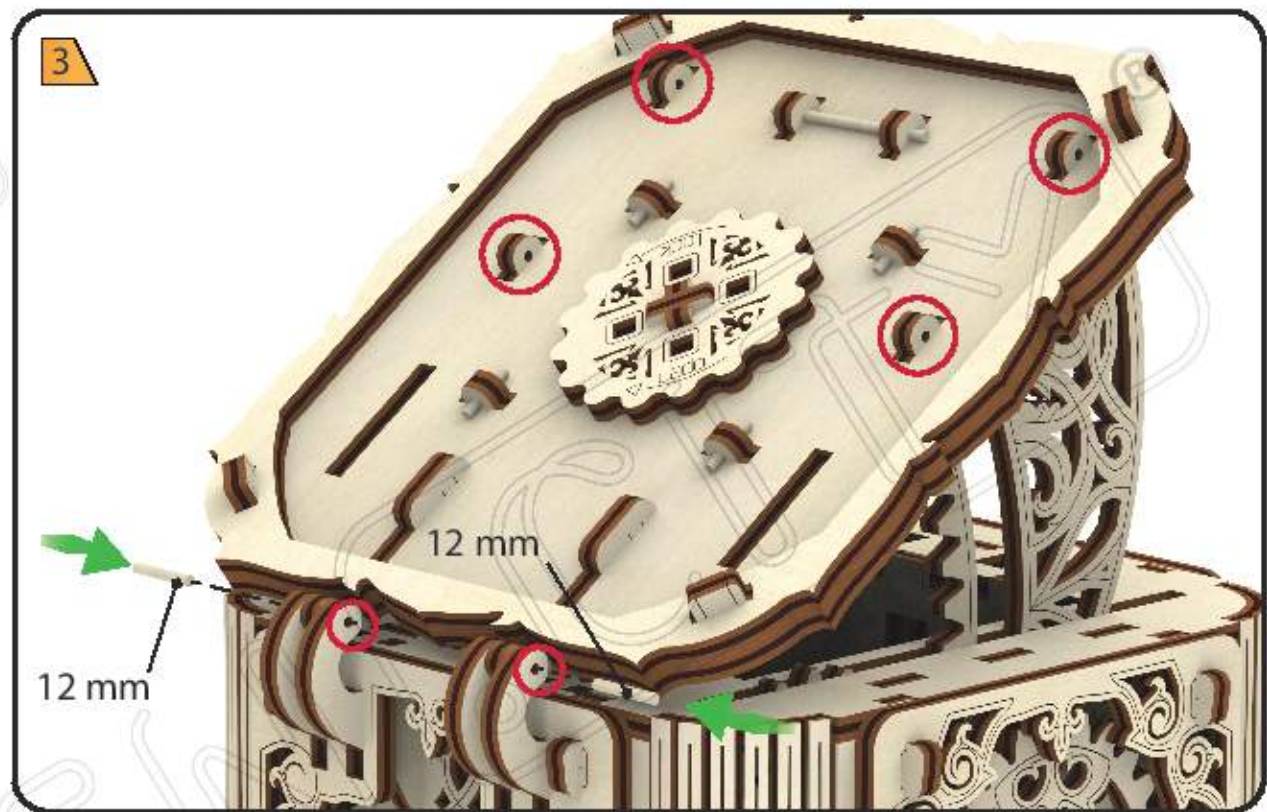

2

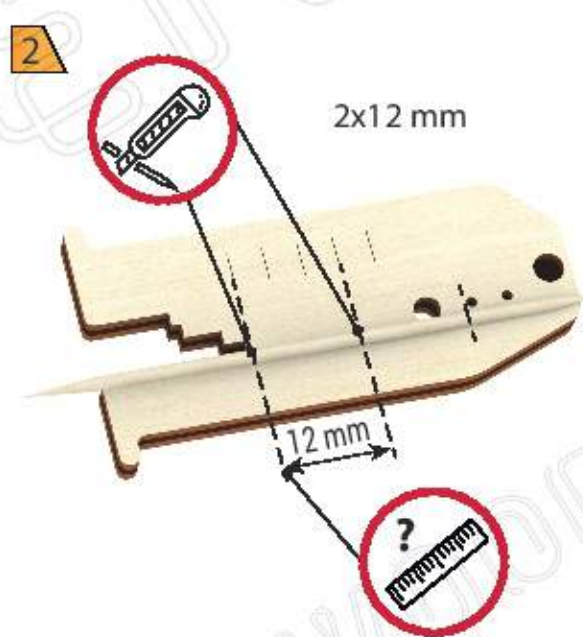

4





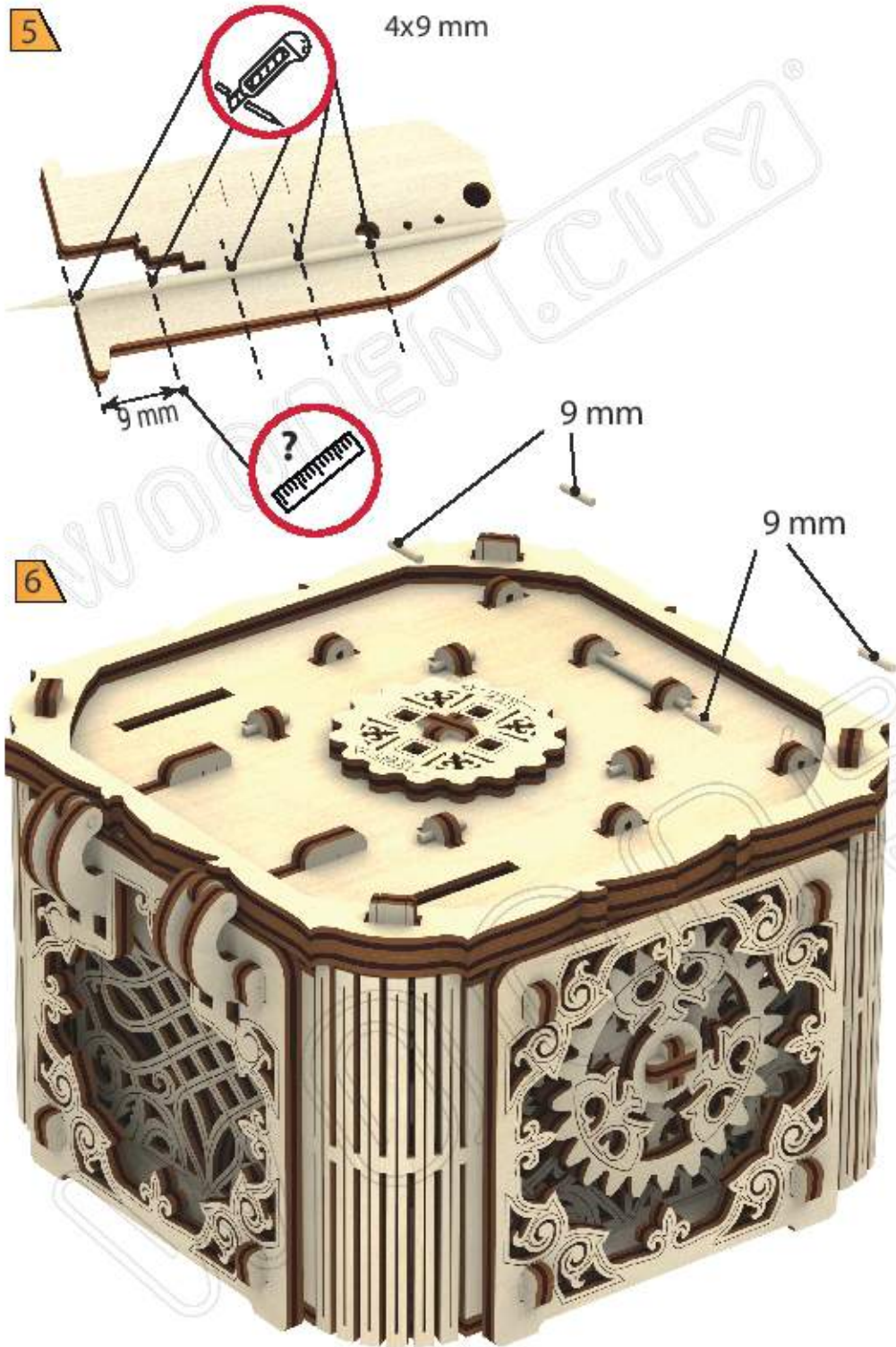

9

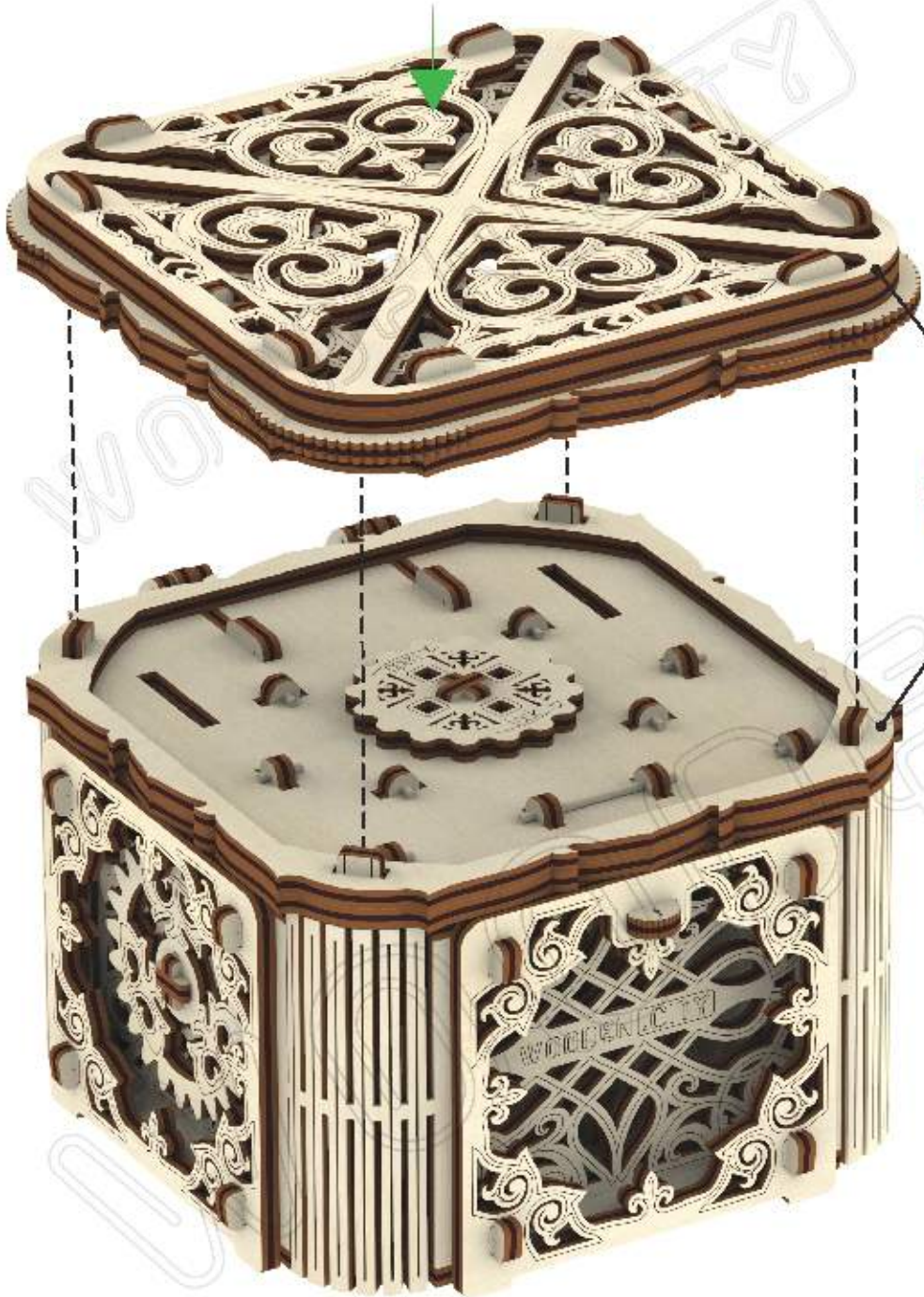

10



11



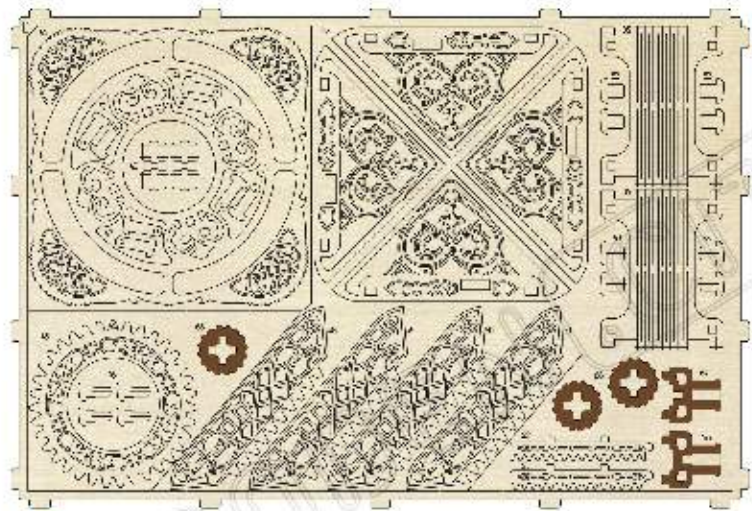

4



1

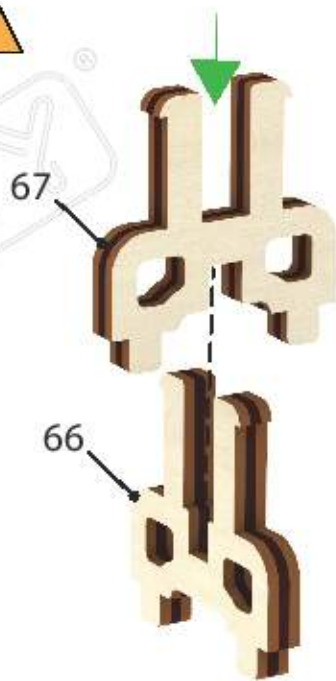

2

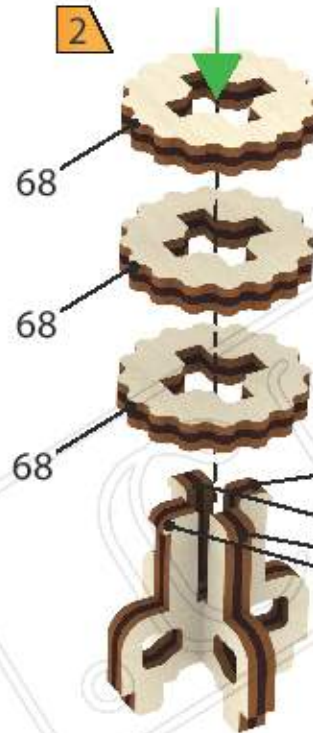

3



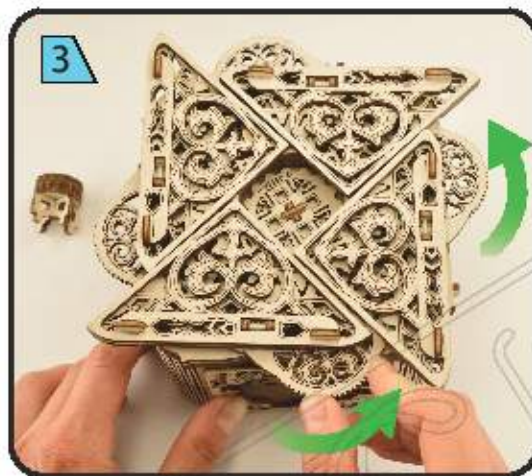
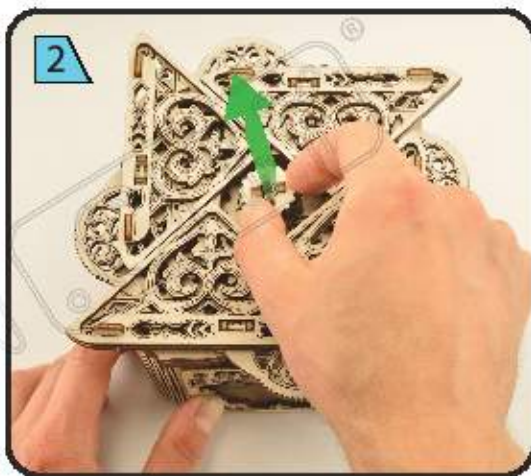
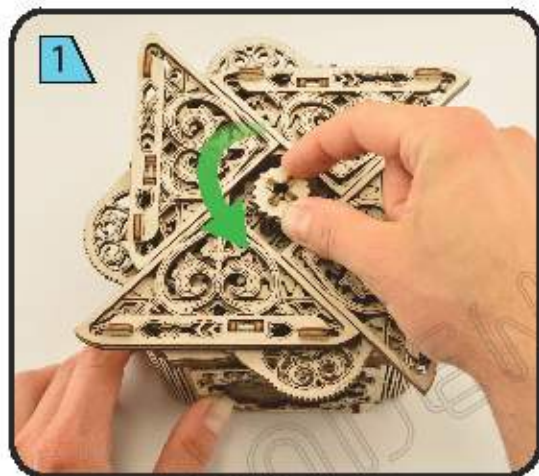

1...4 LOCK



300 min

1...5 OPEN

