

HEXBUG<sup>®</sup>  
PREMIUM

# HEX MODS

RC TUNER CARS

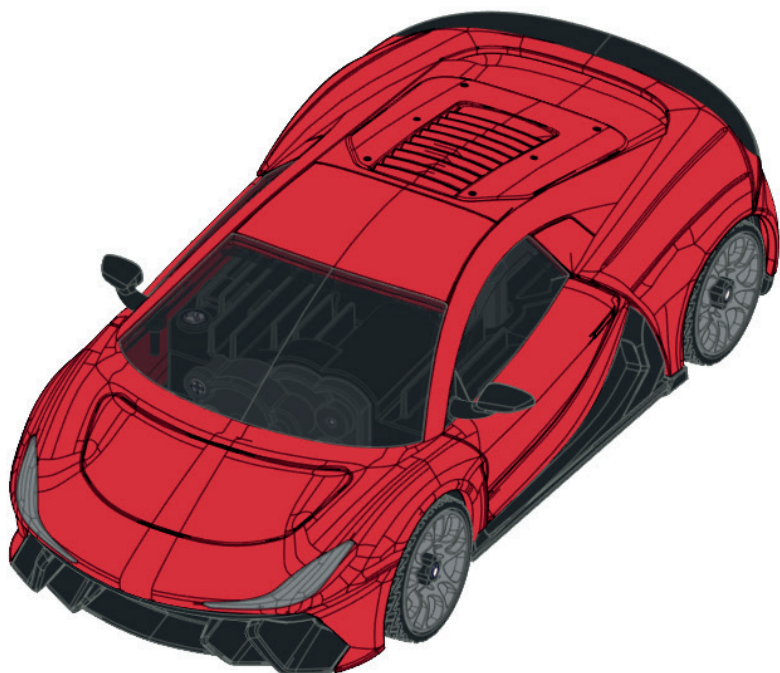

NIGHT HAWK<sup>™</sup>

# Table of Contents/ Sommaire/ Tabla de Contenido/ Inhaltsverzeichnis

Get Started/ Pour commencer/  
Cómo Comenzar/ Einstieg

Body Mods/ Modifications de la Carrosserie/  
Carrocería Mods/ Karosserie-modifikationen

Chassis Mods/ Modifications du châssis/  
Chassis Mods/ Fahrgestellmodifikationen

- 03** Install Body/ Installez la Carrosserie/ Instalar Carrocería/ Karosserie installieren
- 04** Remove Body/ Retirer la Carrosserie/ Remueva la Carrocería/ Karosserie demontieren
- 05** Transmitter & Battery Install/ Transmetteur et Installation des Batteries/ Instalación del Transmisor y la Batería/ Transmitter & Batterieeinbau
- 06** Pairing/ Appairage/ Emparajamiento/ Kopplung
- 07** Transmitter/ Transmetteur/ Transmisor/ Transmitter
- 08** Controls/ Contrôles/ Controles/ Steuerung
- 09** Steering Sensitivity/ Sensibilité de Direction/ Sensibilidad de la Dirección/ Lenkempfindlichkeit
- 10** Speed/ Vitesse/ Velocidad/ Geschwindigkeit
- 11** Steering Trim/ Ajustement de Direction/ Ajuste de Dirección/ Trimmung der Lenkung
- 12** Chassis: Charging/ Châssis: Chargement/ Chasis: Carga/ Fahrgestell: Aufladen
- 13** How to use the tool/ Comment Utiliser l'outil/ Cómo Utilizar la Herramienta/ Verwendung des Werkzeugs
- 14** Barriers/ Barrières/ Barreras/ Begrenzungen
- 15** Front Bumper/ Pare-chocs Avant/ Parachoques Delantero/ Frontstoßfänger
- 16-17** Rear Bumper & Exhaust/ Pare-chocs Arrière & Échappement/ Parachoques Trasero y Escape/ Heckstoßfänger & Auspuff
- 18-19** Replace Spoiler/ Changement de Spoiler/ Reemplazar el Alerón/ Spoiler austauschen
- 20-21** Replace Hood/ Changement de Capot/ Reemplazar el Capó/ Haube austauschen
- 22-23** Replace Roof/ Remplacer le Toit/ Reemplazar Techo/ Dach austauschen
- 24-25** Engine Cover/ Couvert de Moteur/ Cubierta del Motor/ Motorabdeckung
- 26-27** Replace Side Skirts/ Remplacer les Jupes Latérales/ Reemplazar Faldones Laterales/ Seitenschweller austauschen
- 28-29** Install Decals/ Installation des Autocollants/ Instalar Calcomanías/ Aufkleber anbringen
- 30-31** Install Head & Tail Lights/ Installer les Phares Avant et Arrière/ Instale Luces Delanteras y Traseras/ Scheinwerfer & Rückleuchten installieren
- 32** Install Underglow/ Installez Lumières Sous-Châssis/ Instalar Iluminación Bajo Carrocería/ Unterbodenbeleuchtung installieren
- 33** Wheel & Tire Replacement/ Remplacement Des Pneus et Roues/ Reemplazo de Ruedas y Neumáticos/ Rad- und Reifenwechsel
- 35-37** Replace Front Suspension/ Remplacement de la Suspension Avant/ Reemplazar Suspensión Delantera/ Vordere Aufhängung austauschen
- 38-40** Replace Rear Suspension/ Remplacement de la Suspension Arrière/ Reemplazar Suspensión Trasera/ Hintere Aufhängung austauschen
- 41-46** Change Speed/ Changement de Vitesse/ Cambiar Velocidad/ Geschwindigkeit ändern
- 47-48** Steering Link/ Barre de Direction/ Enlace de Dirección/ Spurstange
- 49** RWD, FWD, AWD/ RWD, FWD, AWD/ Tracción Trasera, Tracción Delantera, Tracción Trasera y Delantera/ Antrieb: RWD, FWD, AWD
- 50-56** Remove Rear Differential/ Retirer le Différentiel Arrière/ Retire el Diferencial Trasero/ Hinteres Differential ausbauen
- 57-61** Install Front Differential/ Installer le Différentiel Avant/ Instale el Diferencial Delantero/ Vorderes Differential installieren

1

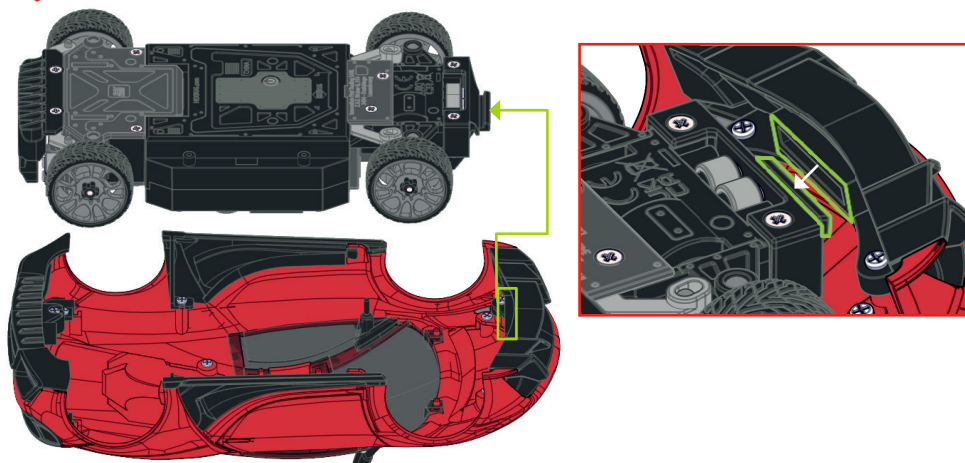

2

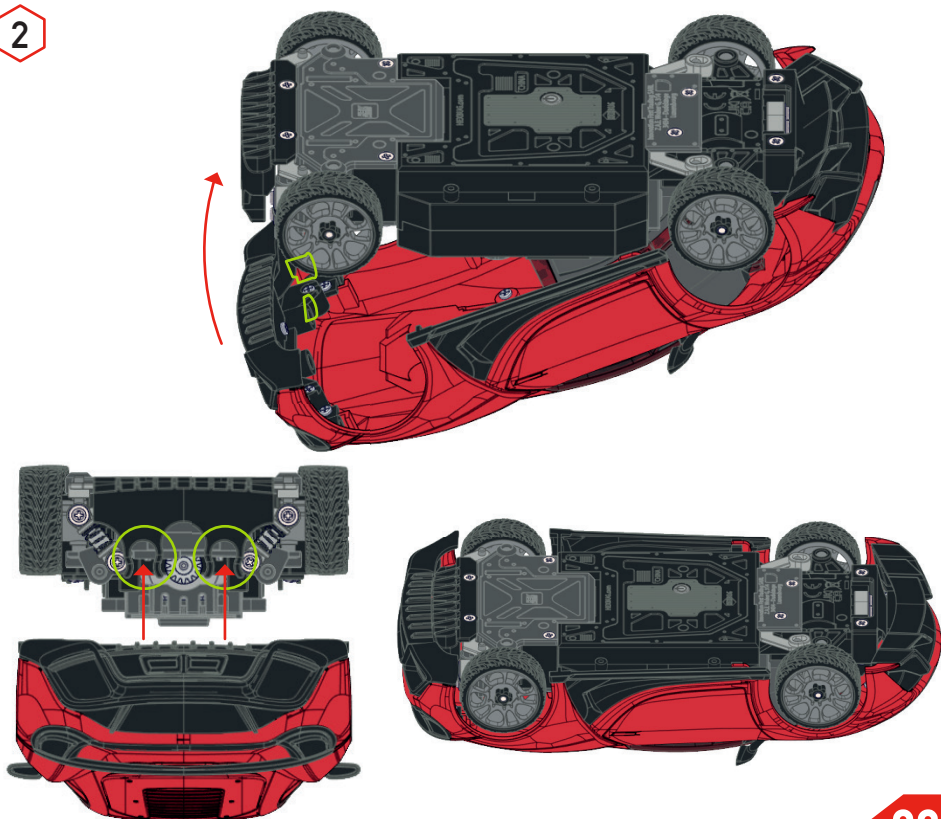

# Remove Body/ Retirer la Carrosserie/ Remueva la Carrocería/ Karosserie demontieren

1

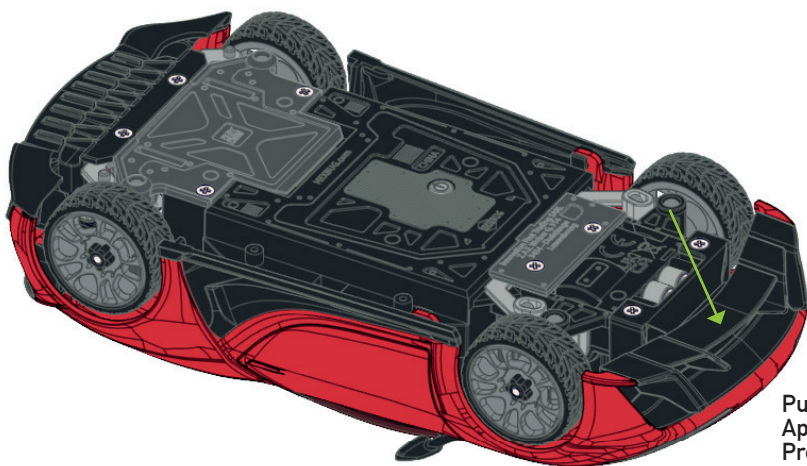

Push/  
Appuyez/  
Presione/  
Drücken

2

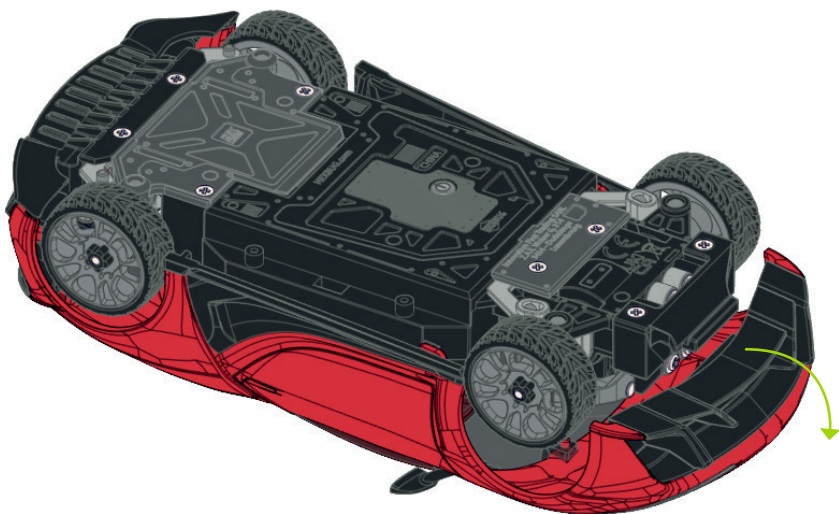

3

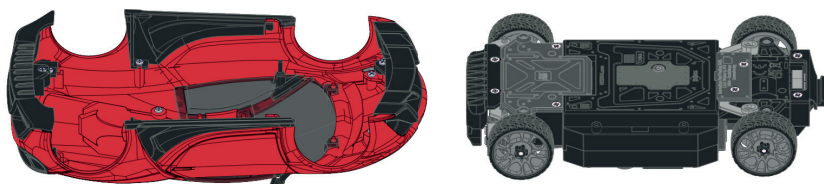

Transmitter & Battery Install/ Transmetteur et Installation des Batteries/  
Instalación del Transmisor y la Batería/ Einlegen der Transmitter-Batterien

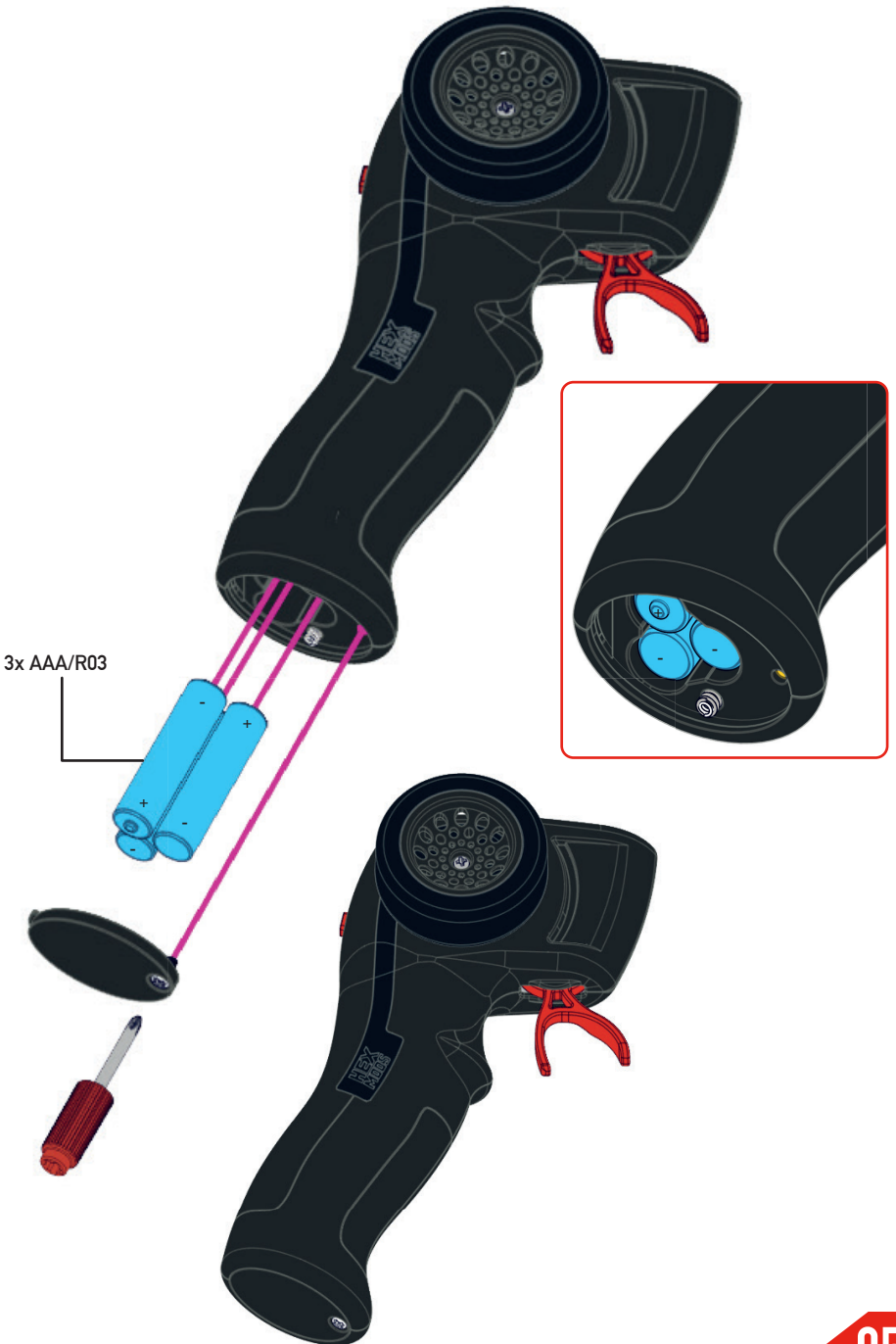

# Pairing/ Appairage/ Emparejamiento/ Kopplung

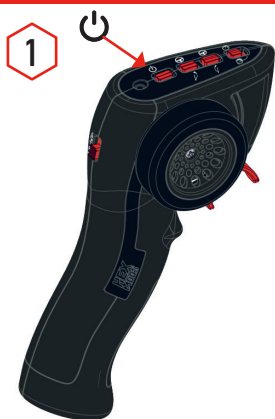

Power on the controller  
Allumez le transmetteur  
Encienda el controlador  
Transmitter einschalten

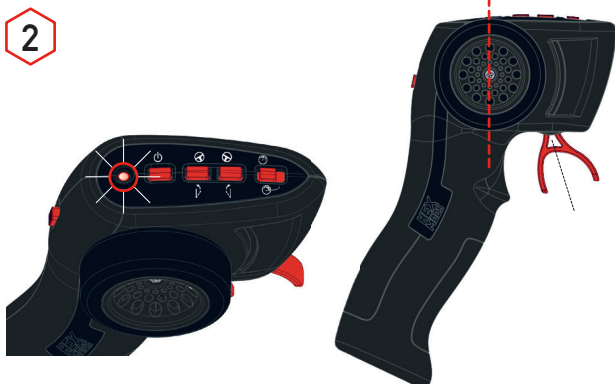

If the controller LED is blinking quickly, make sure the WHEEL and TRIGGER are centered.  
Si la DEL du transmetteur clignote rapidement, assurez-vous que la ROUE et la GÂCHETTE sont centrées  
Si el LED del controlador parpadea rápidamente, asegúrese de que la RUEDA y el GATILLO estén centrados.  
Wenn die LED des Transmitters schnell blinkt, stellen Sie sicher, dass das Rad und der Abzug zentriert sind.

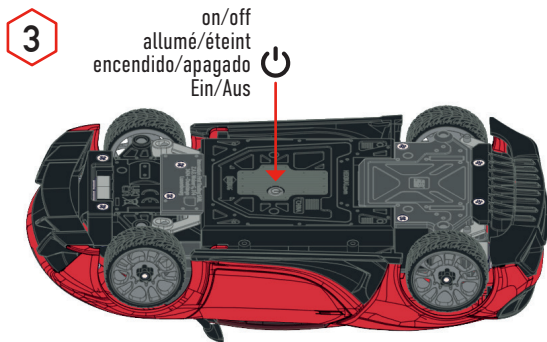

Once the controller LED starts blinking slowly, flip car over and press the power button on the car for 2 seconds.

Une fois que la DEL du transmetteur clignote lentement, retournez la voiture et appuyez sur le bouton d'alimentation de la voiture pendant 2 secondes.

Una vez que el LED del controlador comienza a parpadear lentamente. Da la vuelta al auto y presiona el botón de encendido del auto durante 2 segundos.

Sobald die LED des Transmitters langsam zu blinken beginnt, das Fahrzeug umdrehen und die Einschalttaste am Fahrzeug 2 Sekunden lang drücken.

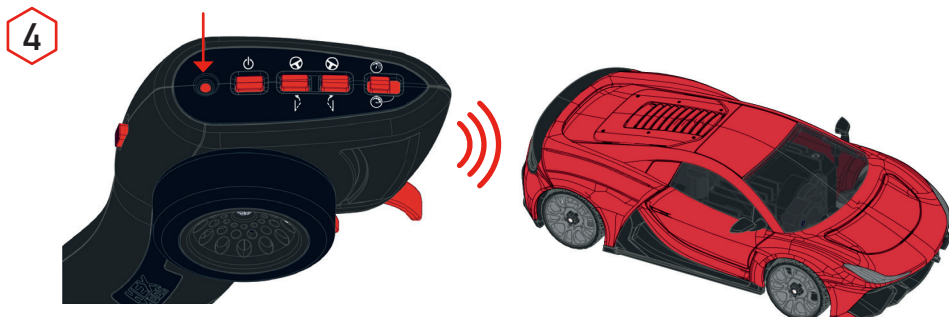

The controller LED turns solid red when it is paired with the car.

La DEL du transmetteur brillera en continue et de couleur rouge quand il est associé avec la voiture.

El LED del controlador se vuelve rojo fijo cuando está emparejado con el automóvil.

Die LED des Transmitters leuchtet konstant rot, wenn er mit dem Fahrzeug gekoppelt ist.

# Transmitter/ Transmetteur/ Transmisor/ Transmitter

1 LED Indicator/ Indicateur DEL/  
Indicador LED/ LED-Anzeige



2 Power Button/ Bouton d'alimentation/  
Botón de Encendido/ Einschalttaste

3 Left Steering Trim/ Ajustement de  
direction gauche/ Ajuste Izquierdo de  
la Dirección/ Linke Lenkeinstellung



4 Right Steering Trim/ Ajustement de  
direction droit/ Ajuste Derecho de la  
Dirección/ Rechte Lenkeinstellung



5 High & Low Speed/ Haute & basse  
vitesse/ Velocidad Alta y Baja/ Hohe &  
niedrige Geschwindigkeit



6 Steering Sensitivity Switch/ Bouton de  
sensibilité de la direction/ Interruptor  
de Sensibilidad de la Dirección/  
Schalter für Lenkungsempfindlichkeit

7 Steering Wheel/ Volant/ Volante/  
Lenkrad

8 Throttle Trigger/ Gâchette d'accélérateur/  
Gatillo del Acelerador/ Gashebel

9 Battery Door/Couvercle de  
batterie/ Puerta de la Batería/  
Batterieabdeckung

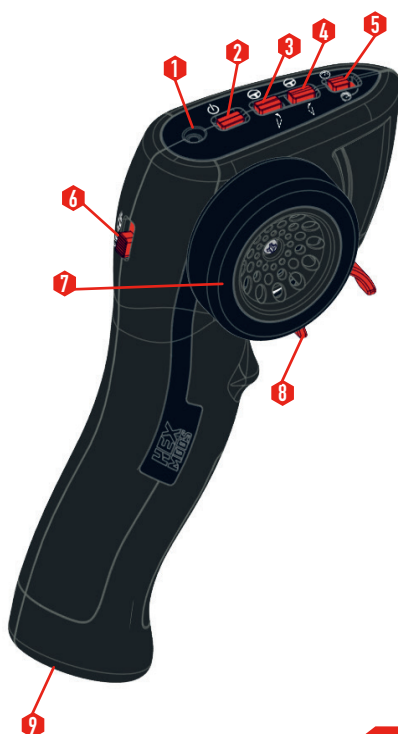
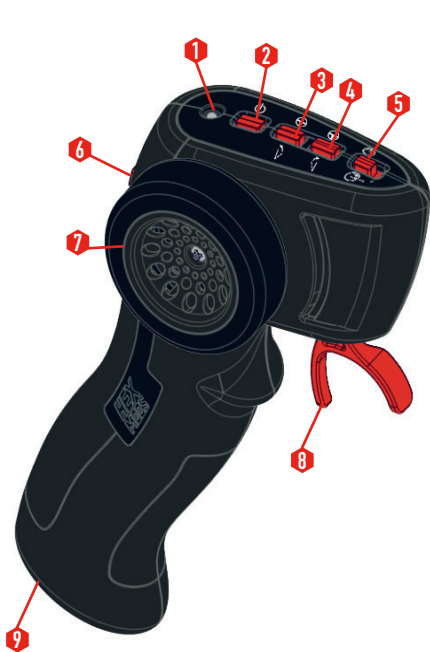

# Controls/ Contrôles/ Controles/ Steuerung



Move trigger forward once to brake, move trigger forward twice to reverse.

Déplacez la gâchette une fois vers l'avant pour freiner, déplacez la gâchette deux fois vers l'avant pour reculer.

Mueva el gatillo hacia adelante una vez para frenar, mueva el gatillo hacia adelante dos veces para retroceder.

Zum Bremsen Abzug einmal nach vorne drücken, für Rückwärtsfahrt zweimal nach vorne drücken



# Steering Sensitivity/ Sensibilité de Direction/ Sensibilidad de la Dirección/ Lenkungsempfindlichkeit

Low Steering Sensitivity/  
Sensibilité de Direction Basse/  
Sensibilidad Baja de la Dirección/  
Geringe Lenkungsempfindlichkeit

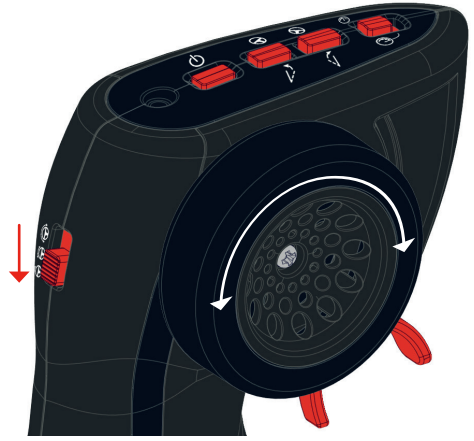

Medium Steering Sensitivity/  
Sensibilité de Direction Moyenne/  
Sensibilidad Media de Dirección/  
Mittlere Lenkungsempfindlichkeit

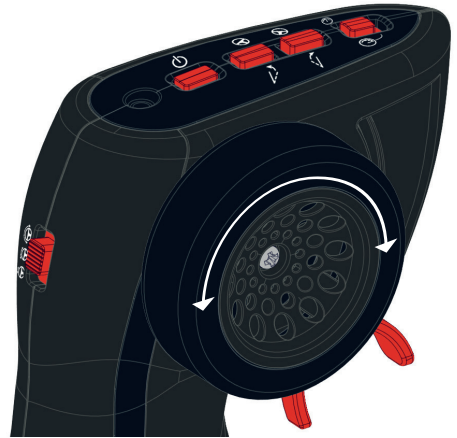

High Steering Sensitivity/  
Sensibilité de Direction Haute/  
Sensibilidad Alta de Dirección/  
Hohe Lenkungsempfindlichkeit

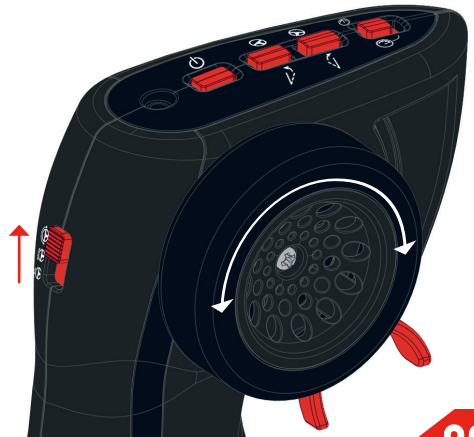

# Speed/ Vitesse/ Velocidad/ Geschwindigkeit

Low Speed/ Basse Vitesse/ Velocidad Baja/ Niedrige Geschwindigkeit



High Speed/ Haute Vitesse/ Velocidad Alta/ Hohe Geschwindigkeit



## Steering Trim/ Ajustement de Direction/ Ajuste de Dirección/ Lenkeinstellung

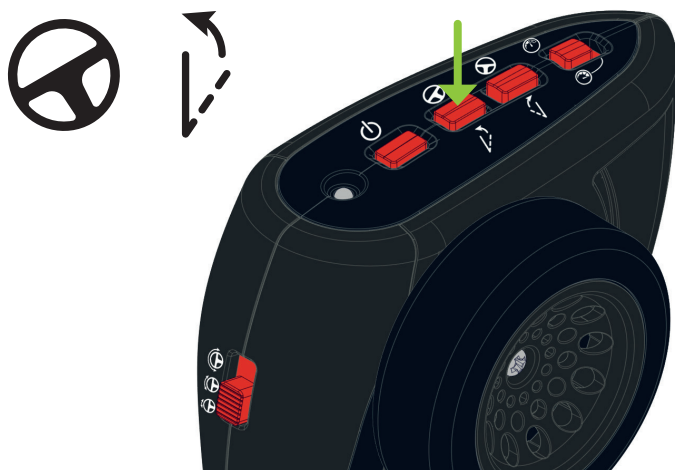

If car is turning right without touching the steering wheel, press left trim button to correct the car as needed.

Si la voiture tourne à droite sans que le volant soit tourné, appuyez sur le bouton d'ajustement de la direction gauche pour corriger la direction comme nécessaire.

Si el automóvil gira a la derecha sin tocar el volante, presione el botón de ajuste izquierdo para corregir el automóvil según sea necesario.

Wenn das Fahrzeug nach rechts zieht, ohne das Lenkrad zu berühren, für Korrektur die linke Trimmaste drücken.

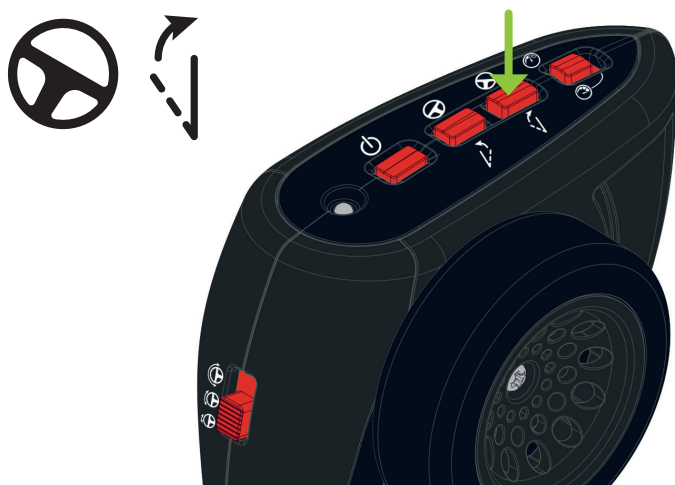

If car is turning left without touching the steering wheel, press right trim button to correct the car as needed.

Si la voiture tourne à gauche sans que le volant soit tourné, appuyez sur le bouton d'ajustement de la direction droite pour corriger la direction comme nécessaire.

Si el automóvil gira a la izquierda sin tocar el volante, presione el botón de ajuste derecho para corregir el automóvil según sea necesario.

Wenn das Fahrzeug nach links zieht, ohne das Lenkrad zu berühren, für Korrektur die rechte Trimmaste drücken.

# Chassis: Charging/ Châssis: Chargement/ Chasis: Carga/ Fahrgestell: Aufladen

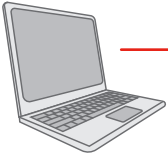

Plug into a usb port or wall adapter.

Branchez dans un port usb ou un adaptateur mural.

Conectar a un puerto usb o adaptador de pared.

An USB-Anschluss oder Steckdose anschließen.

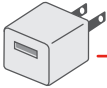

Use only supplied USB cable for charging.  
N'utilisez que le fil USB inclus pour charger.  
Utilice solo el cable USB suministrado para cargar.  
Zum Aufladen nur das mitgelieferte USB-Kabel verwenden.

Light is on if it is charging.  
Lumière s'allume quand elle se recharge.  
La luz está encendida si se está cargando.  
LED leuchtet während des Ladevorgangs.



When light is off, it has finished charging.  
Lorsque la lumière s'éteint, la charge est terminée.  
Cuando la luz está apagada, ha terminado de cargarse.  
LED erlischt nach dem Ladevorgang.

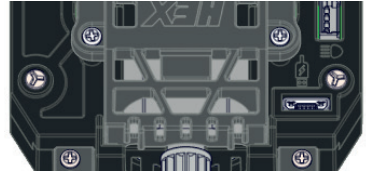

1 HOUR CHARGE TIME - 20 MINUTES PLAY TIME\*  
\*Length of playtime varies depending upon use.  
1 HEURE DE CHARGE - 20 MINUTES DE TEMPS DE JEU\*  
\* La durée du temps de jeu varie en fonction de L'utilisation.  
TIEMPO DE CARGA DE 1 HORA - 20 MINUTOS DE TIEMPO DE REPRODUCCIÓN\*  
\*La duración del tiempo de juego varía según nosotros.  
1 STUNDE LADEZEIT - 20 MINUTEN SPIELZEIT\*  
\*Die Länge der Spielzeit variiert je nach Nutzung.

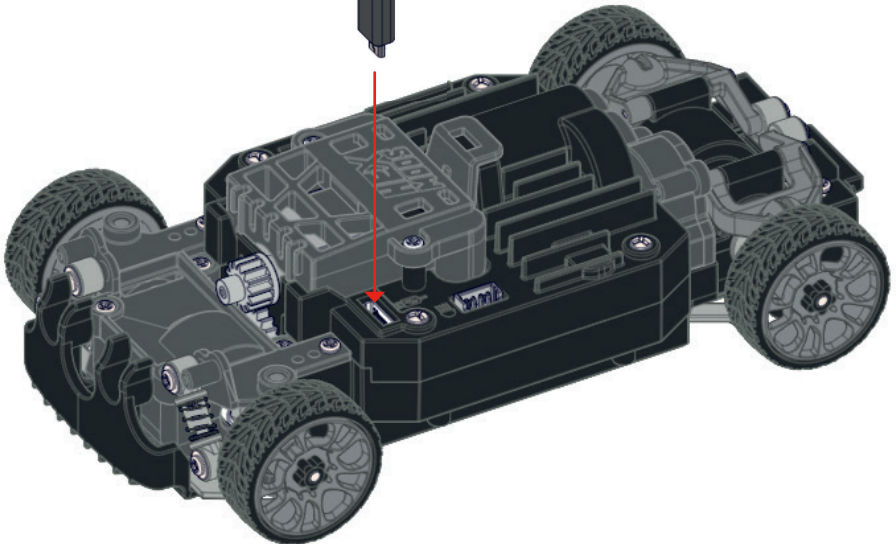

# How to use the tool/ Comment Utiliser l'outil/ Cómo utilizar la Herramienta/ Verwendung des Werkzeugs

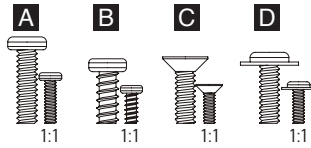

Check each step for the correct screw type/  
Vérifier chaque étape pour le type de vis  
correct/  
Verifique en cada paso el tipo de tornillo  
correcto/  
Bei jedem Schritt auf den richtigen  
Schraubentyp achten.

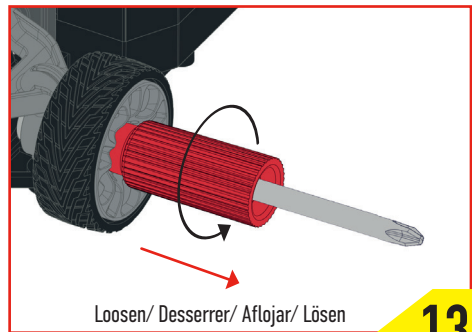
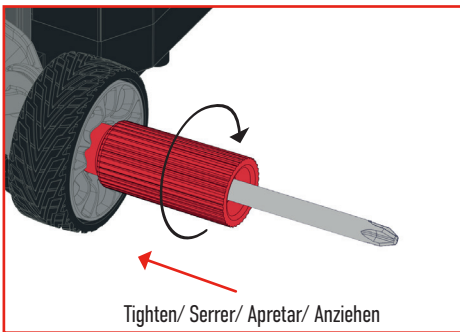
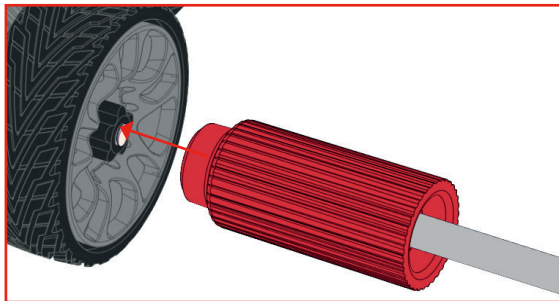
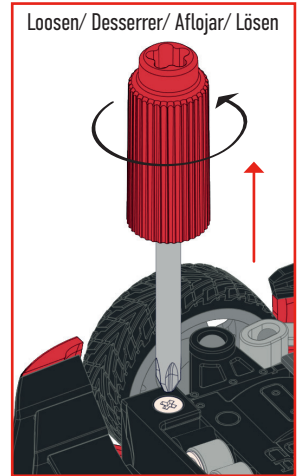
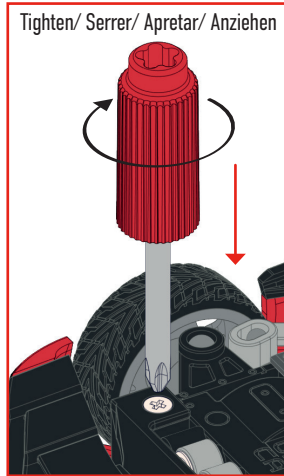
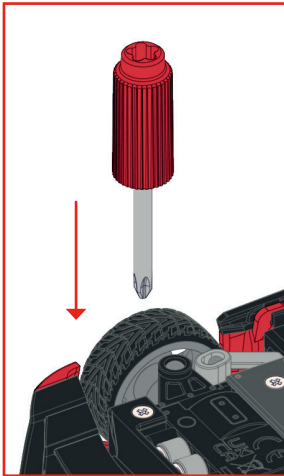

# Front Bumper/ Pare-chocs Avant/ Parachoques Delantero/ Frontstoßfänger

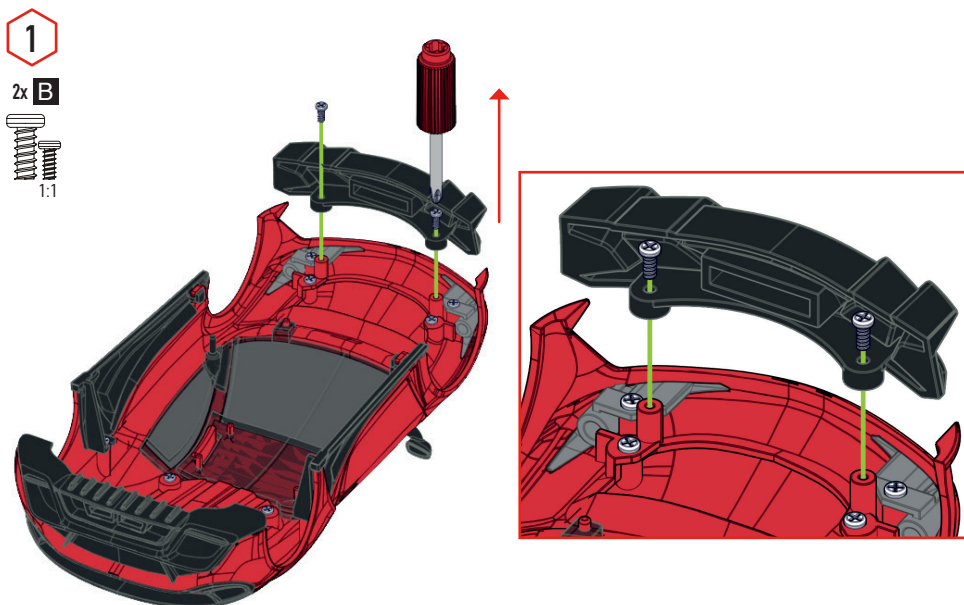

**2**

Options/ Options/ Opciones/ Optionen

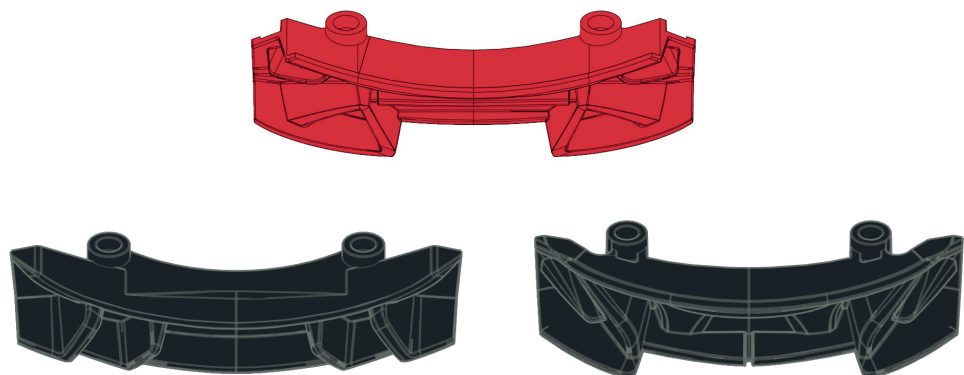

3

2x B

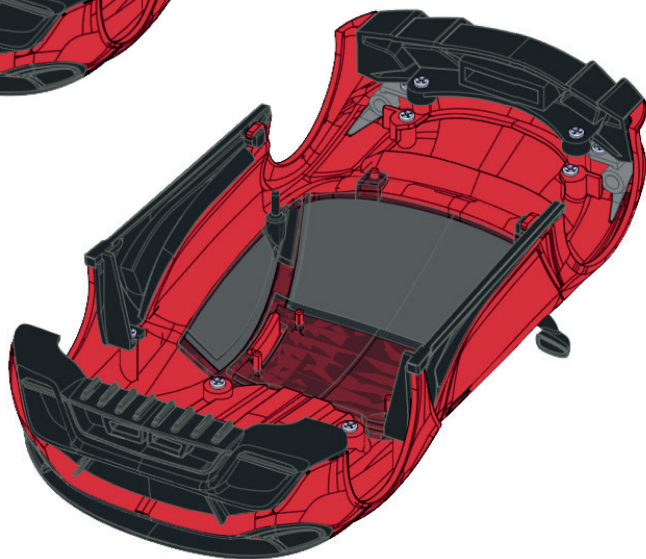
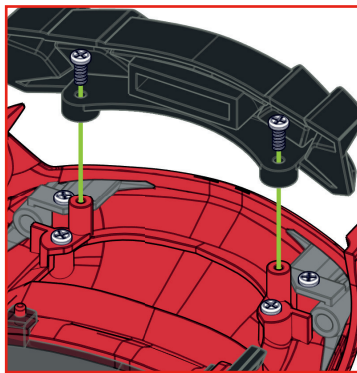
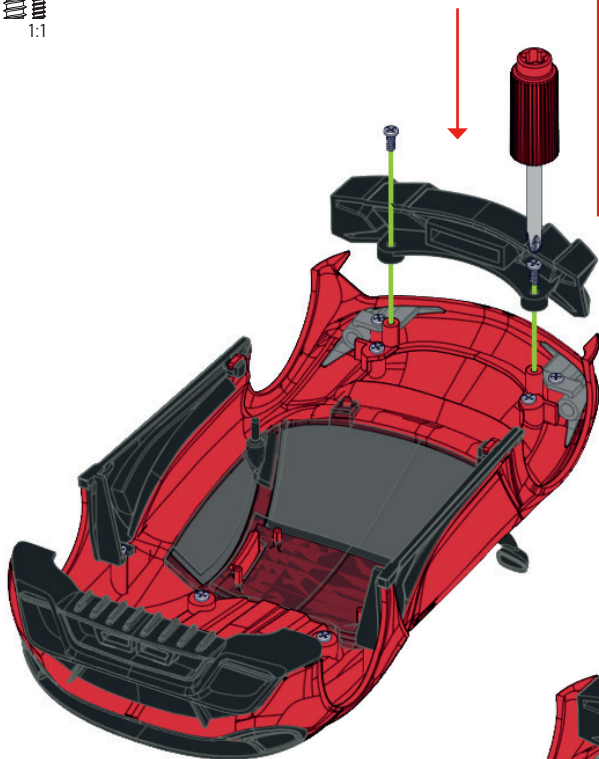

# Rear Bumper & Exhaust/ Pare-chocs Arrière & Échappement/ Parachoques Trasero y Escape/ Heckstoßfänger & Auspuff

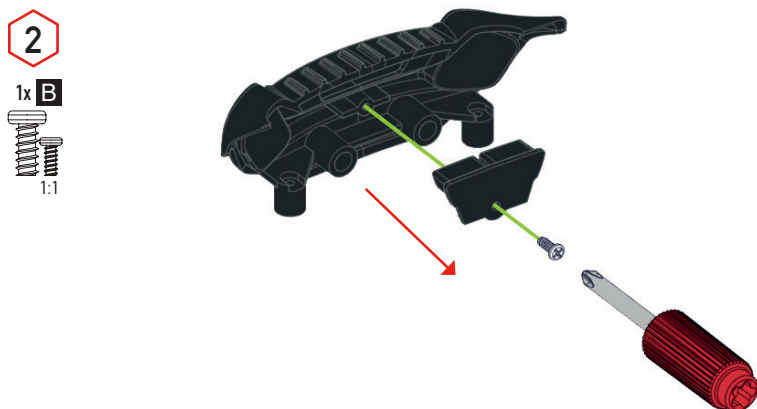
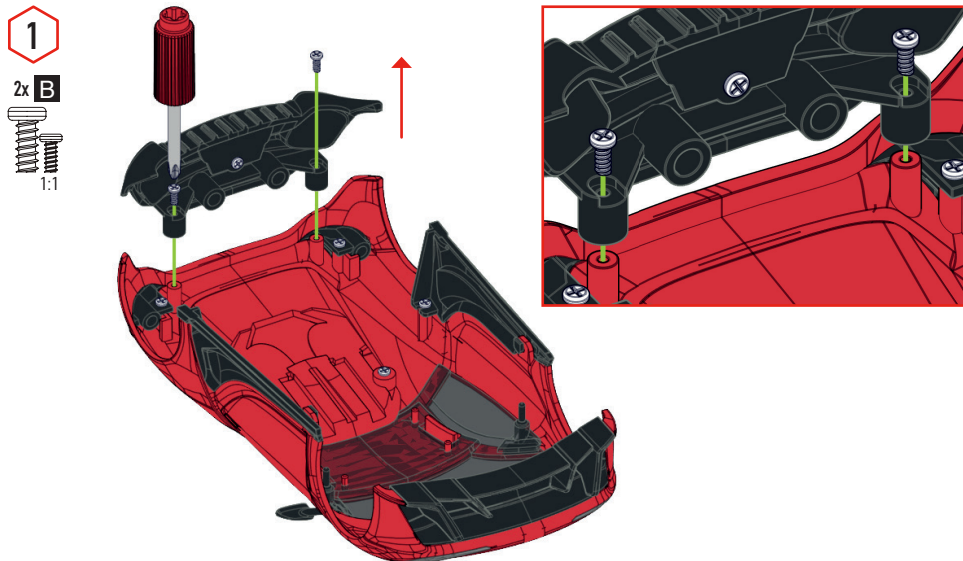

**3** Options/ Options/ Opciones/ Optionen

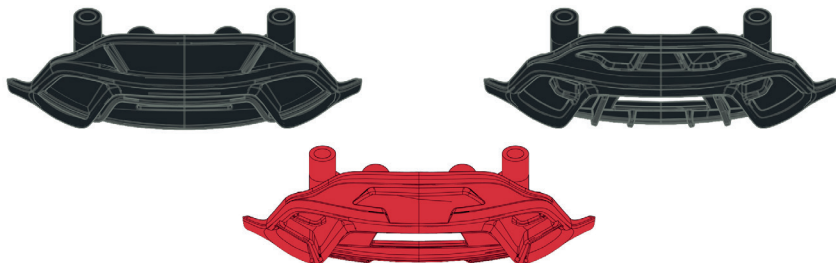



4

Options/ Options/ Opciones/ Optionen

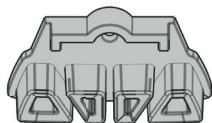

5

1x B

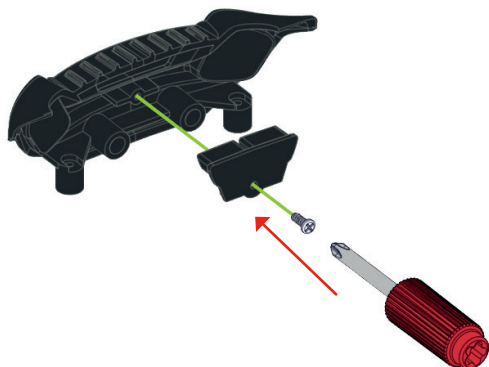

6

2x B

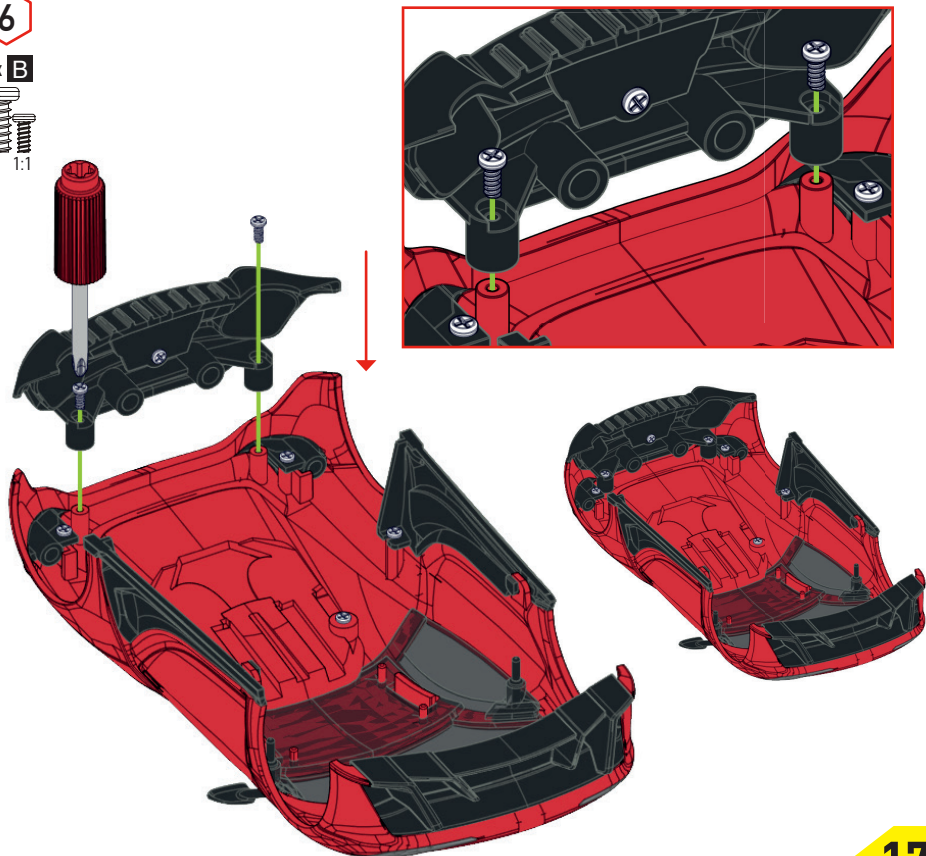

# Replace Spoiler/ Changement de Spoiler/ Reemplazar el Alerón/ Spoiler austauschen

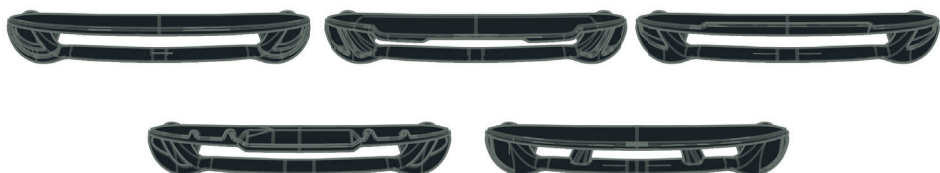
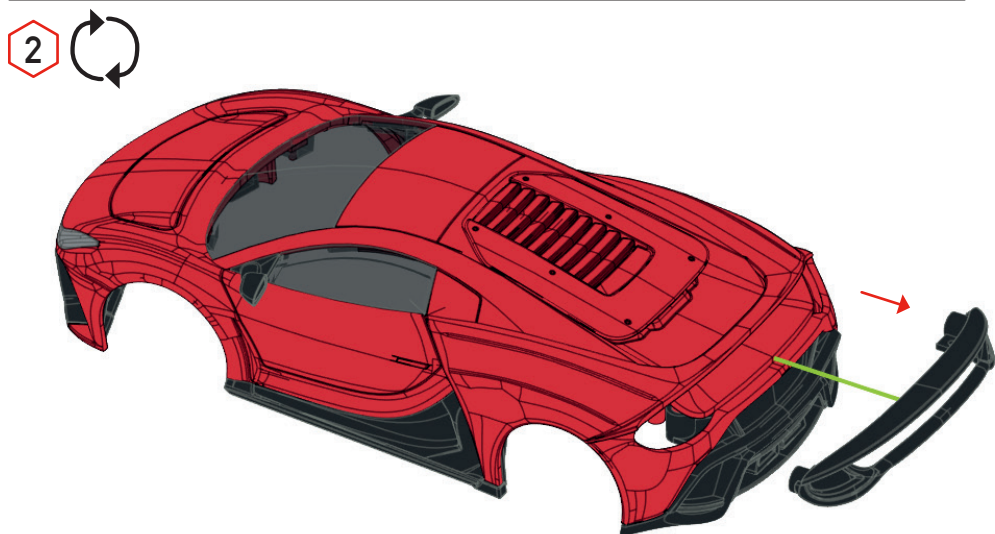
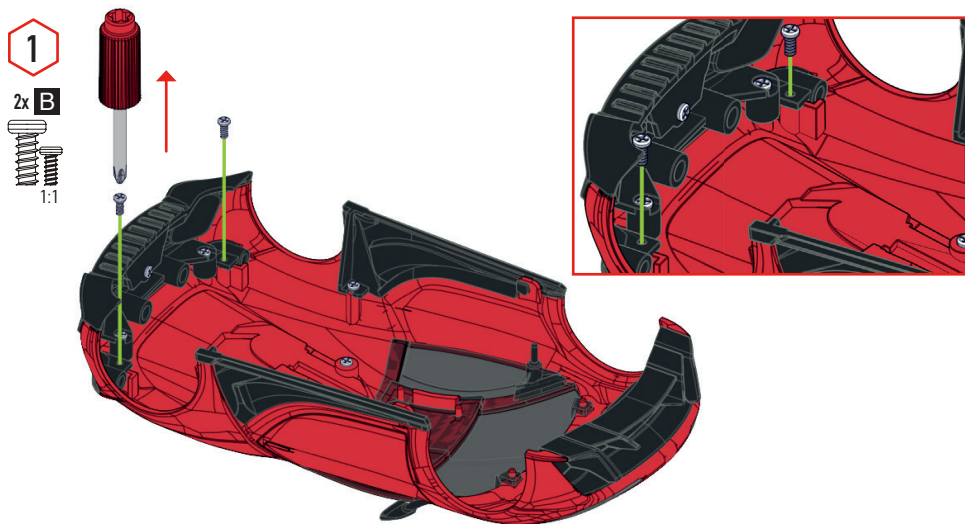

4

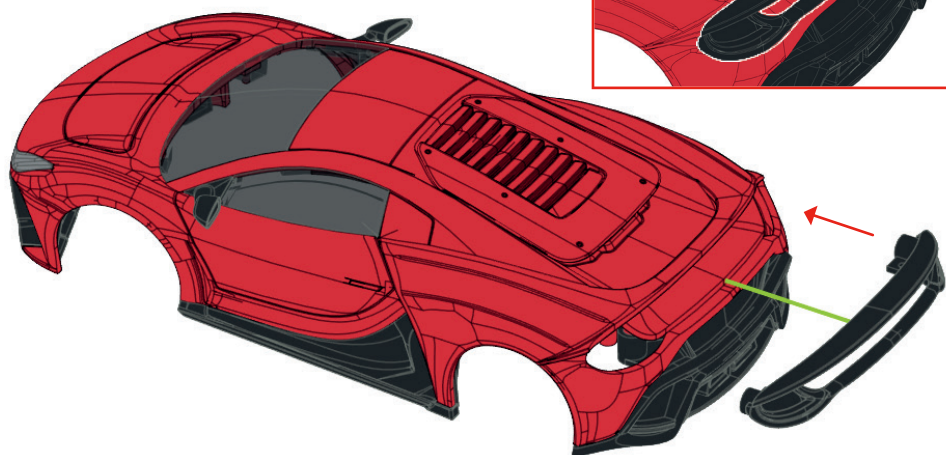

5



2x B



1:1

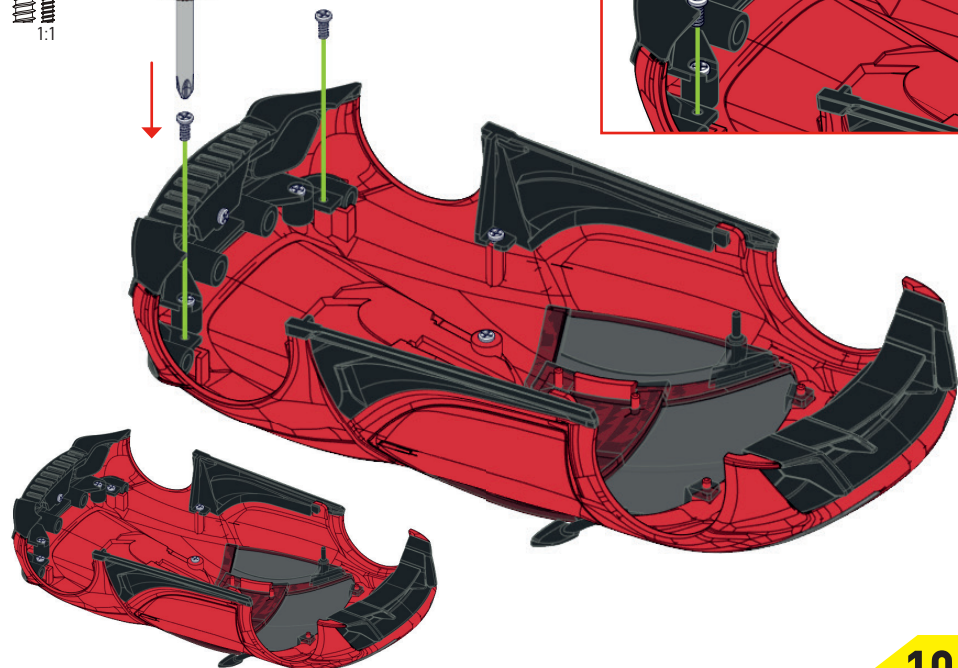

# Replace Hood/ Changement de Capot/ Reemplazar el Capó/ Haube austauschen

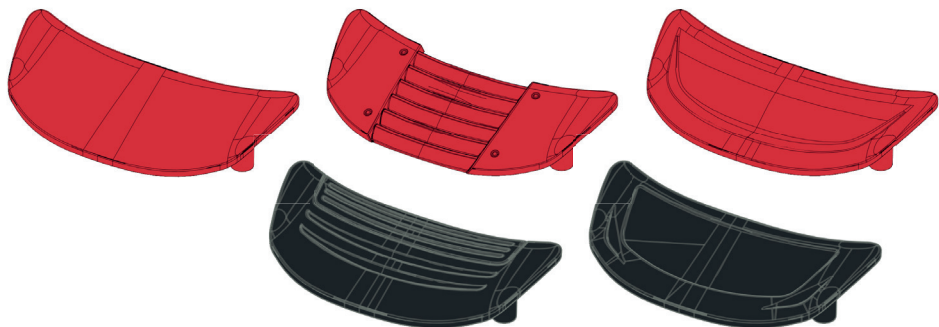
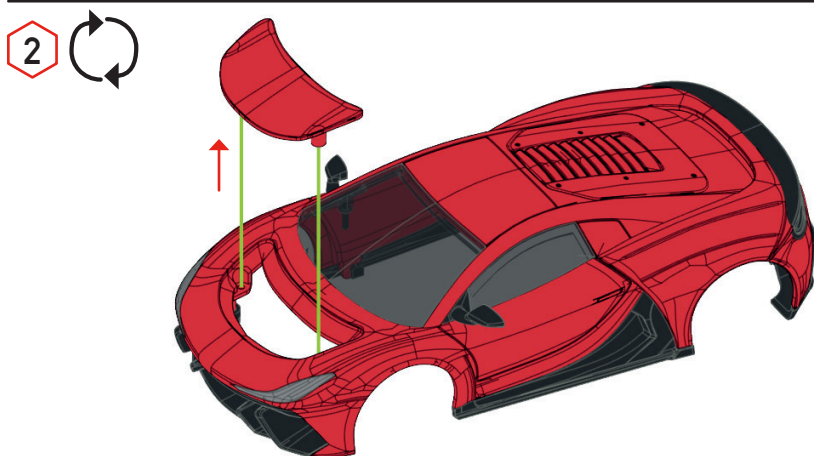
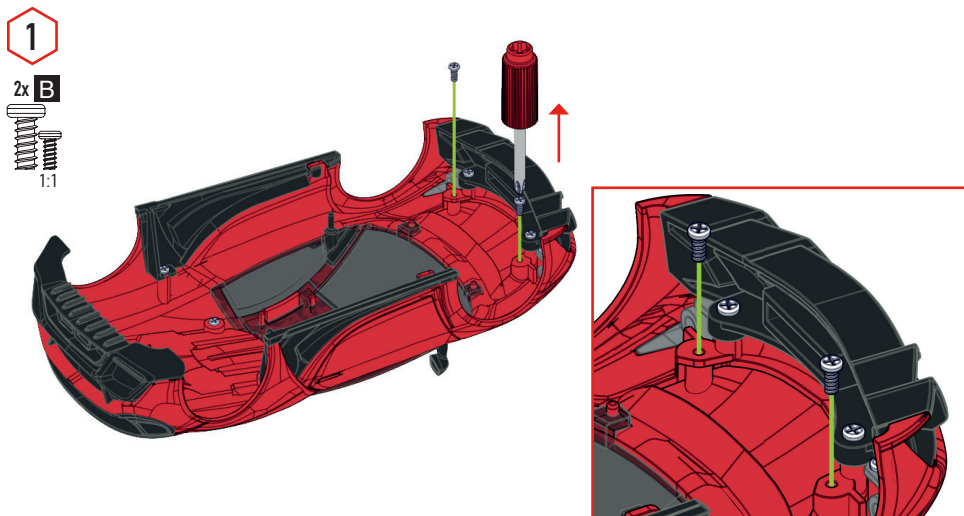

4

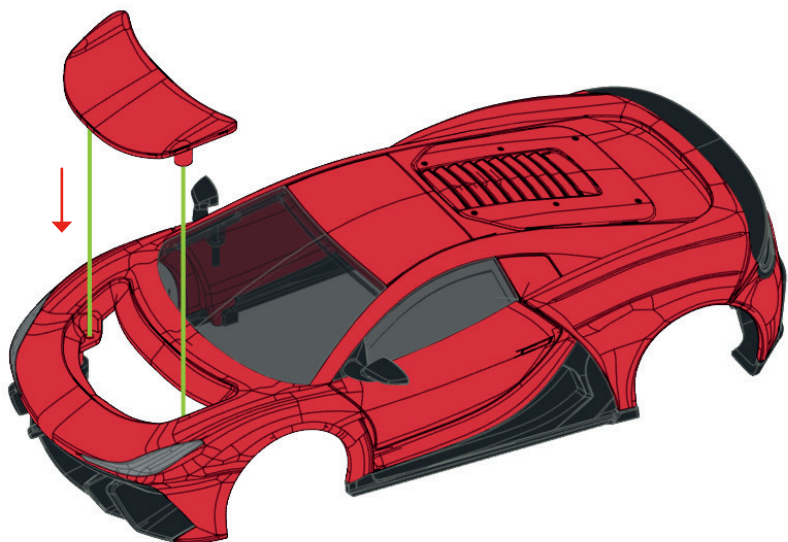

5

2x **B**  
1:1

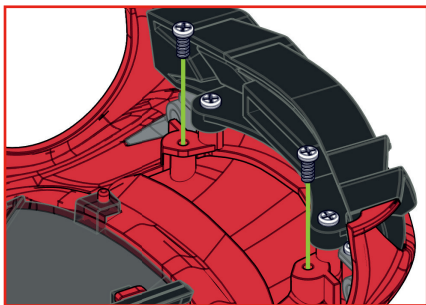
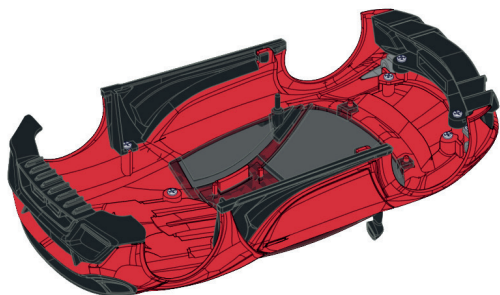
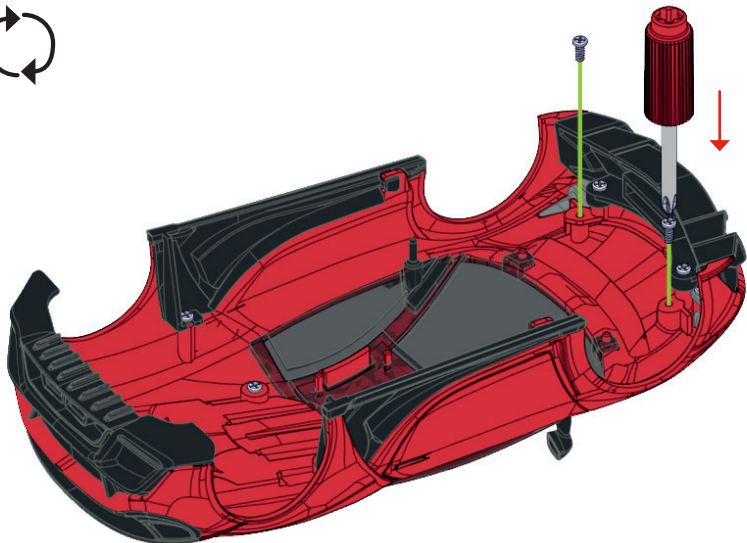

# Replace Roof/ Remplacer le Toit/ Reemplazar Techo/ Dach austauschen

1

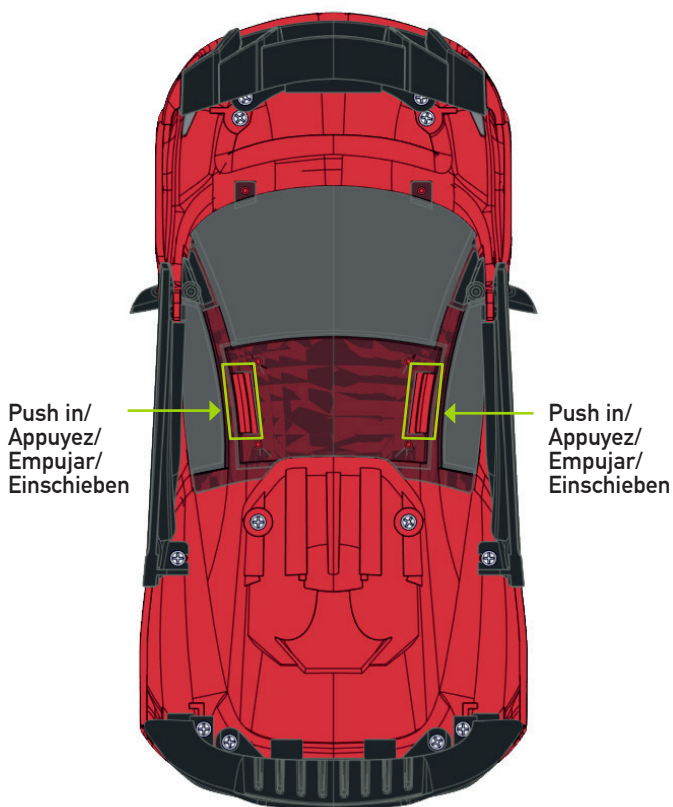

2

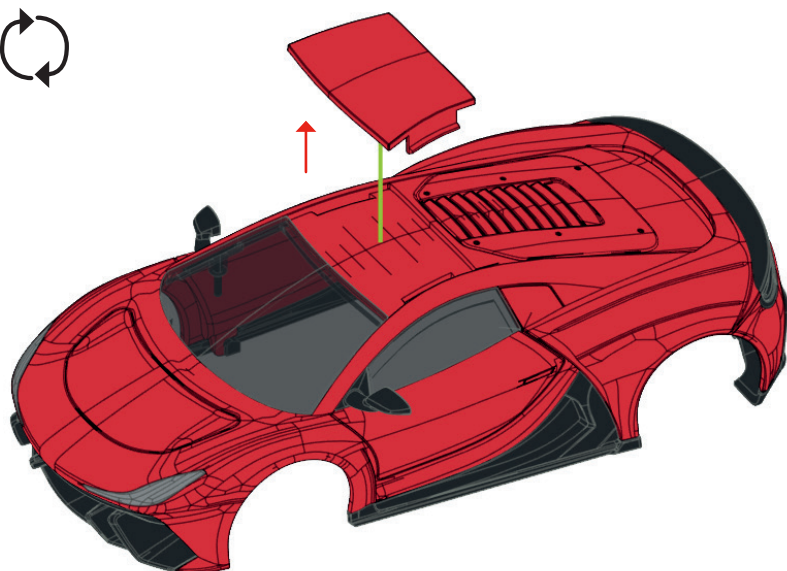

3

Options/ Options/ Opciones/ Optionen

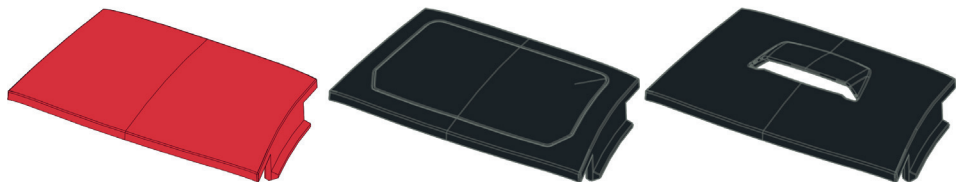

4

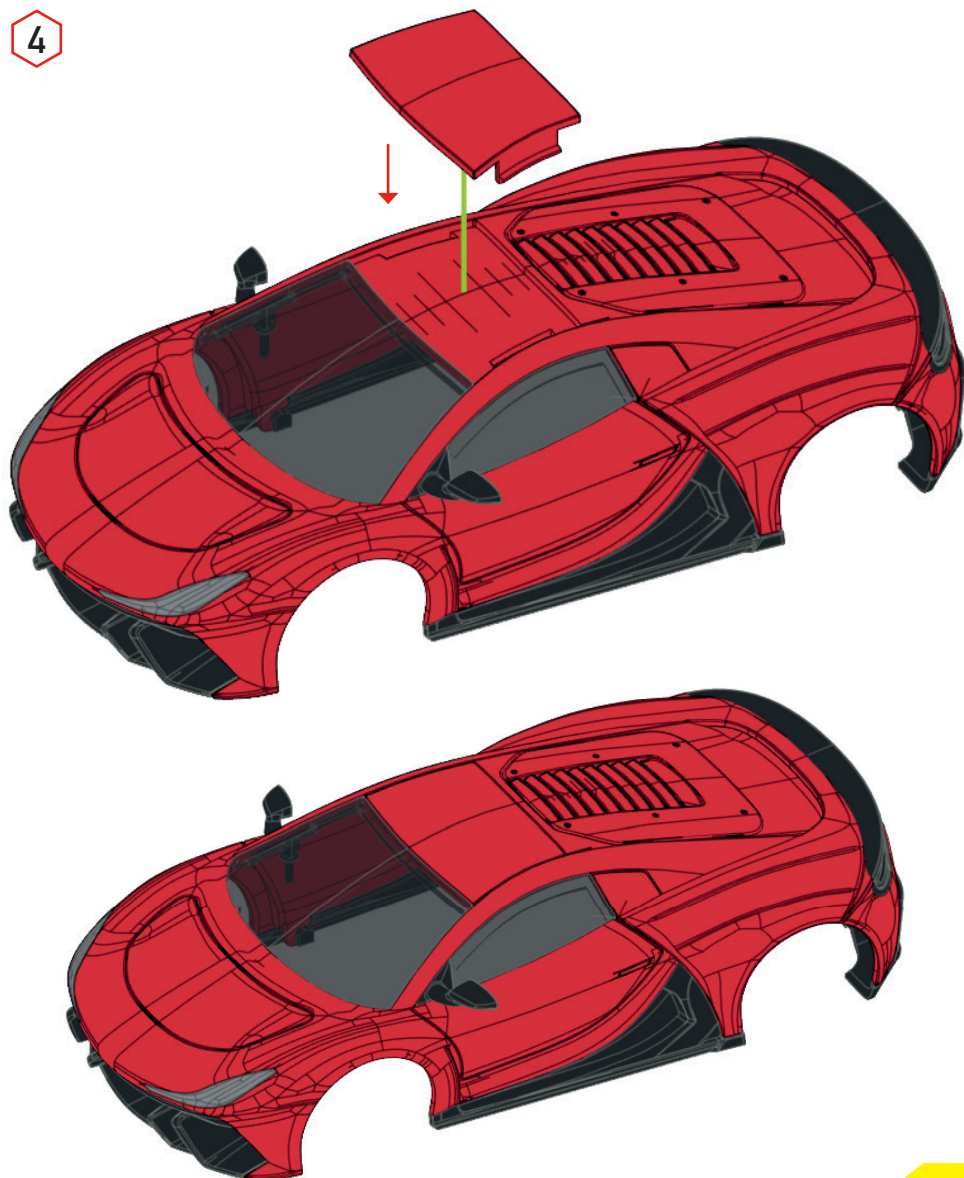

# Engine Cover/ Couvert de Moteur/ Cubierta del Motor/ Motorabdeckung

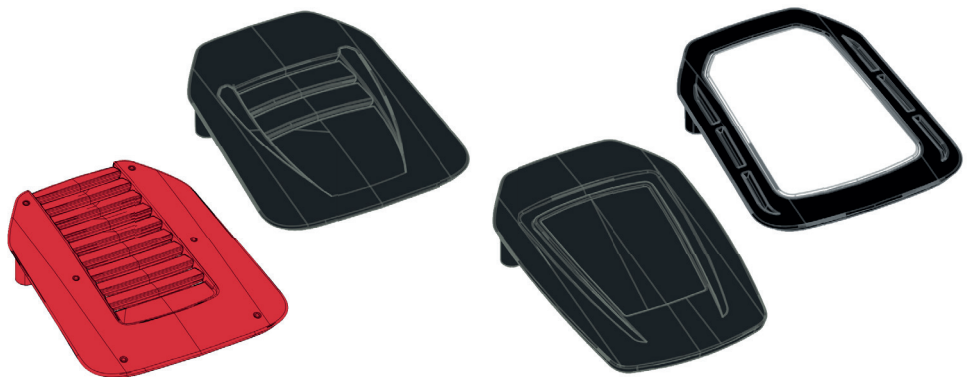
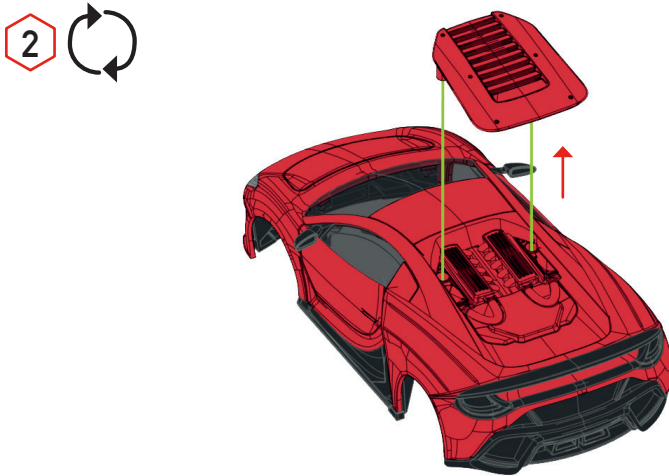
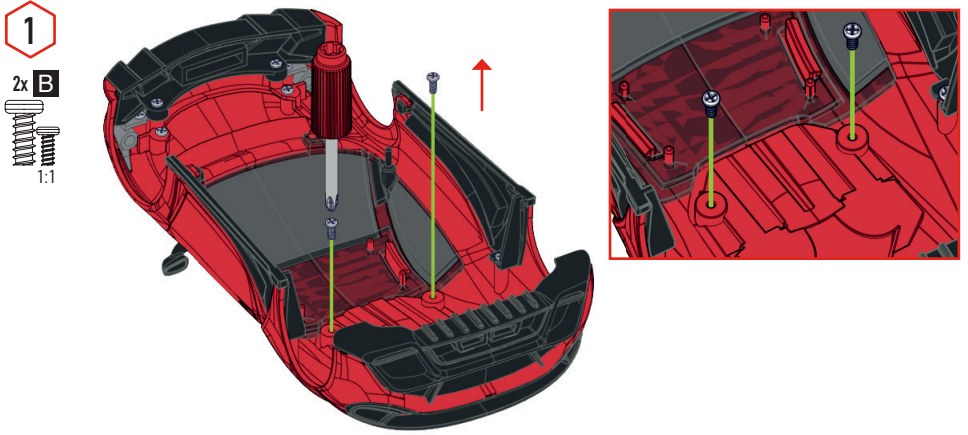



4

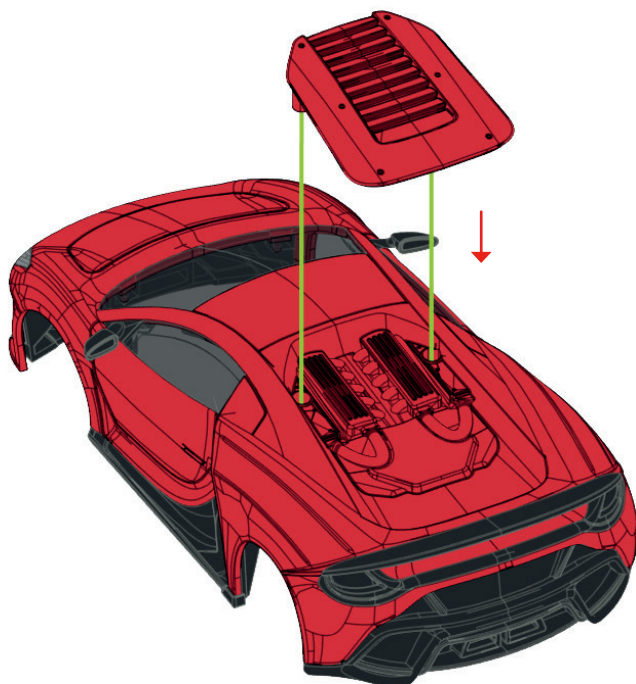

5

2x **B**  
1:1

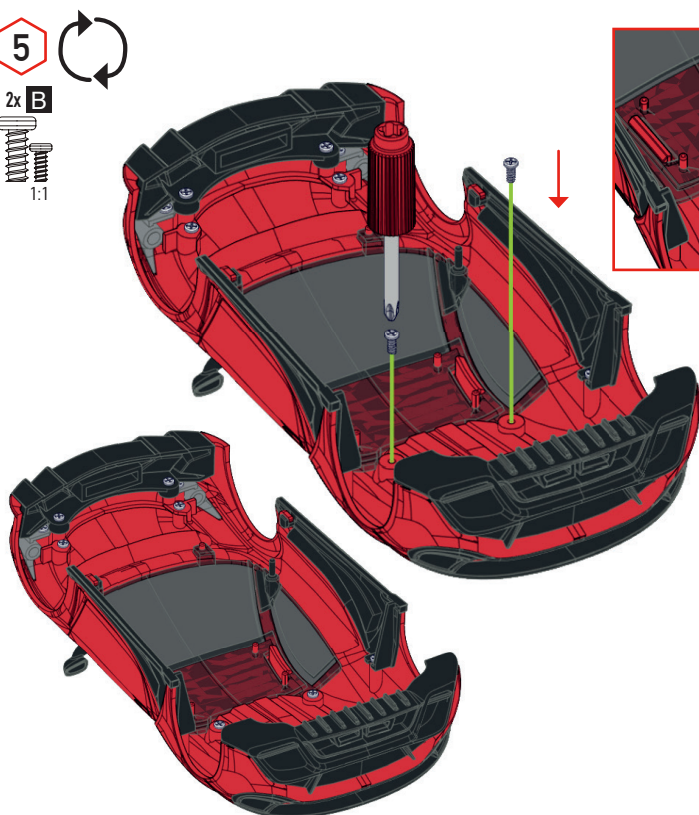

# Replace Side Skirts/ Remplacer les Jupes Latérales/ Reemplazar Faldones Laterales/ Seitenschweller austauschen

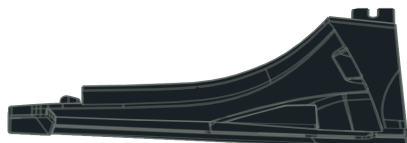
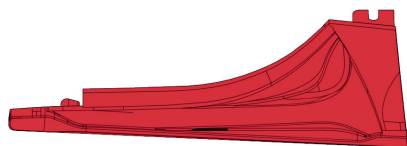
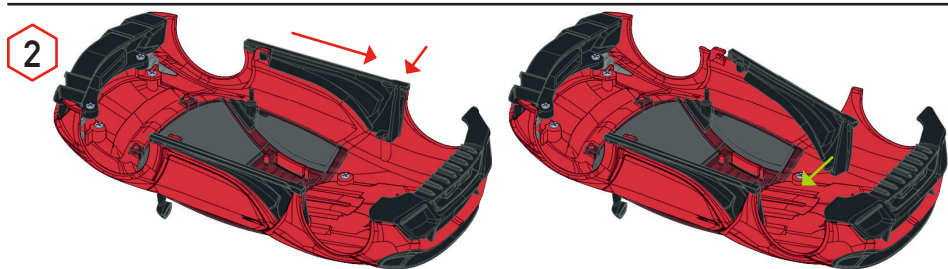
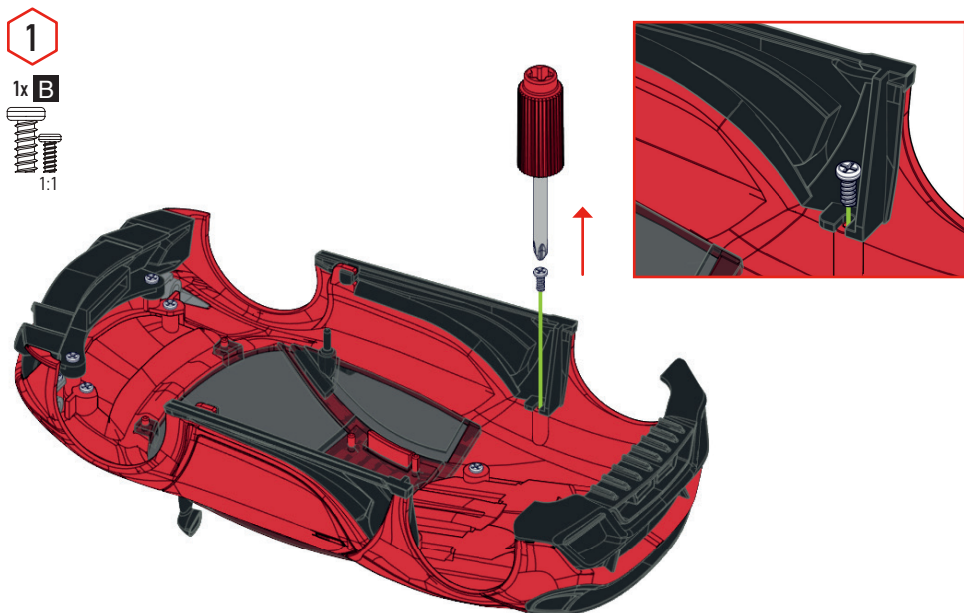

4

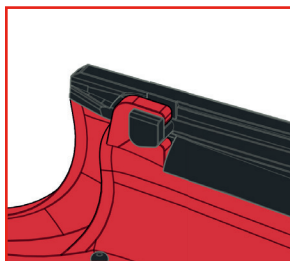
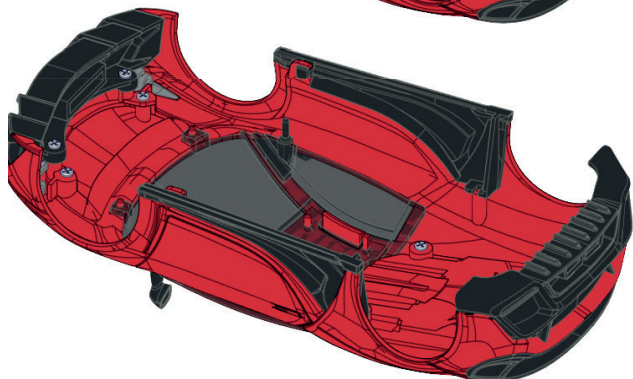
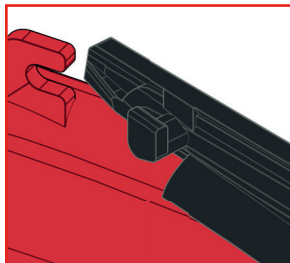
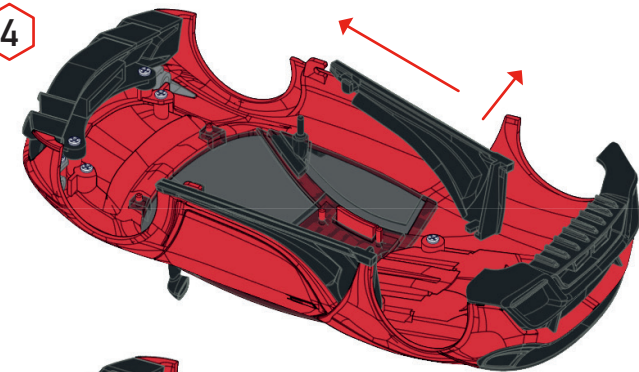

5

1x B  
  
1:1

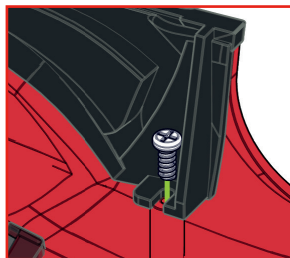
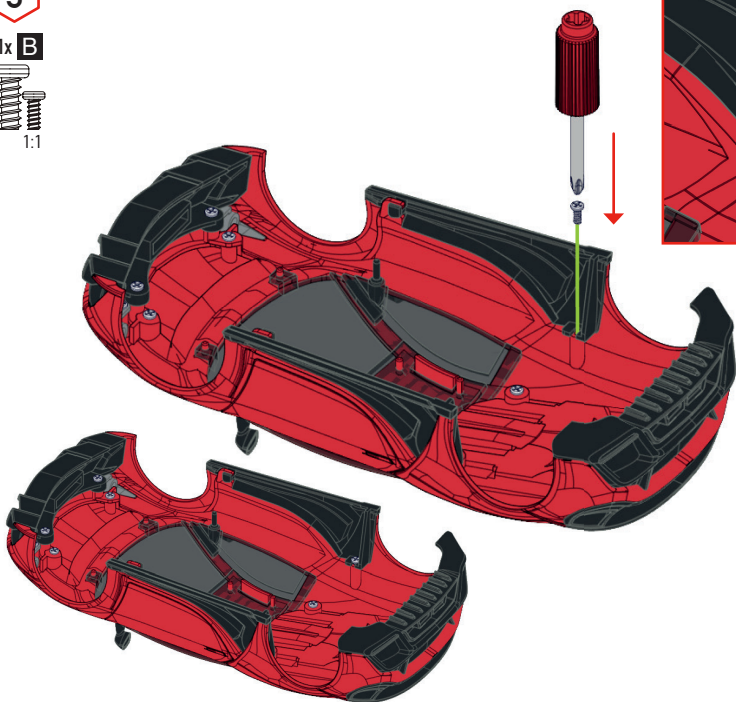

# Install Decals/ Installation des Autocollants/ Instalar Calcomanías/ Aufkleber anbringen

Options/ Options/ Opciones/ Optionen

 = Sticker Numbers/  
Autocollants/  
Pegatinas/  
Aufkleber Nummern

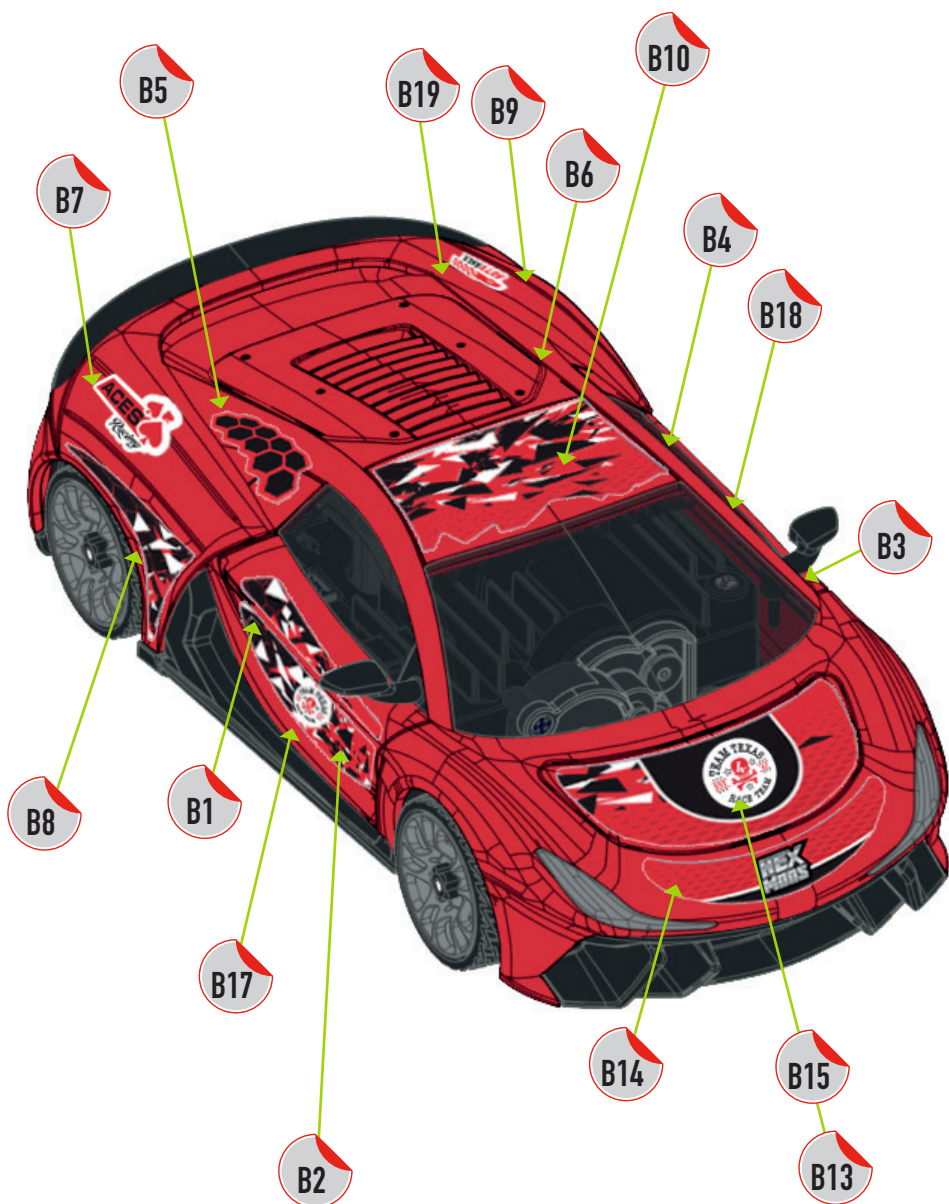

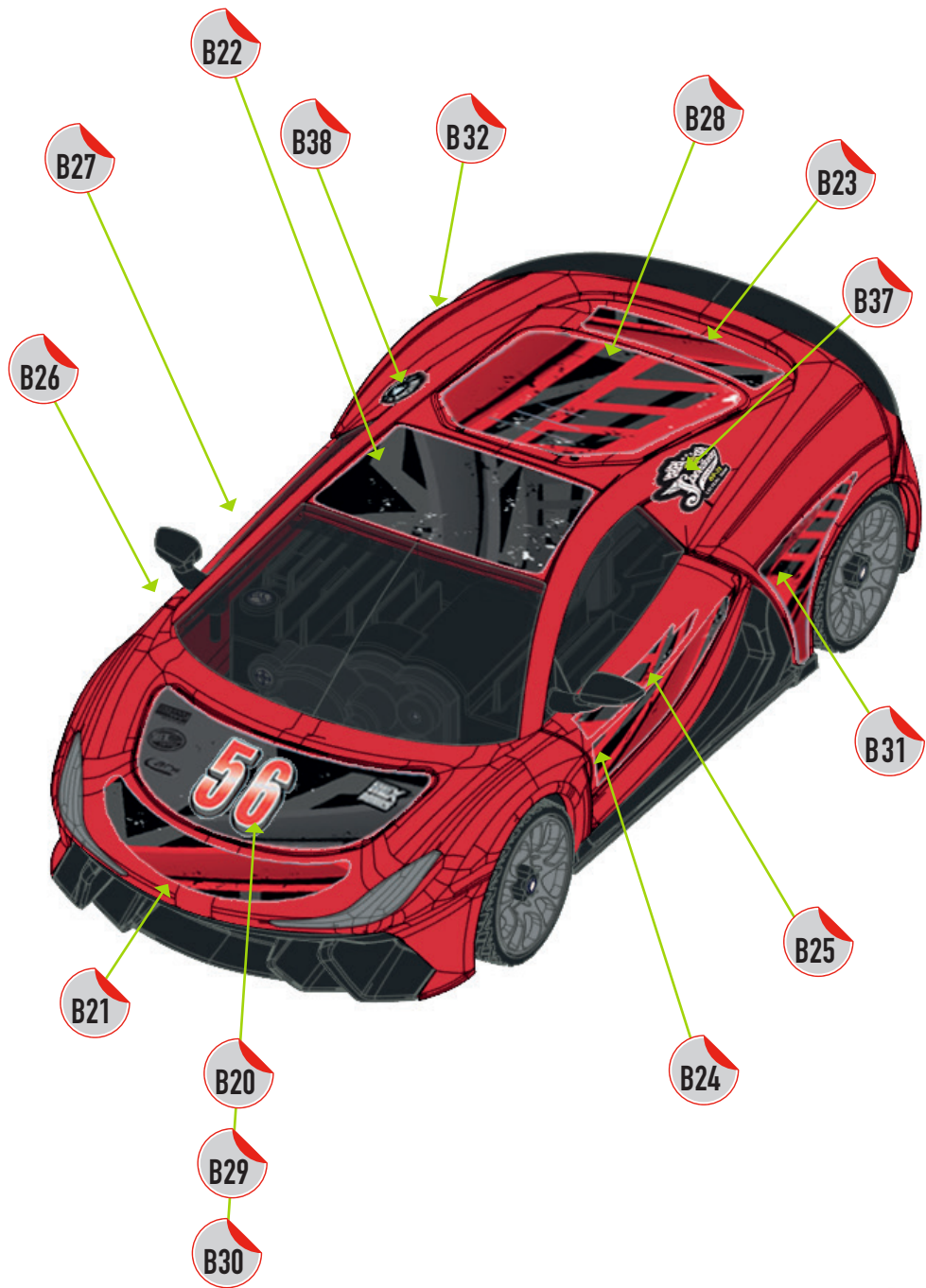

# Install Head & Tail Lights/ Installer les Phares Avant et Arrière/ Instale Luces Delanteras y Traseras/ Scheinwerfer & Rückleuchten installieren

1

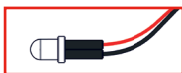
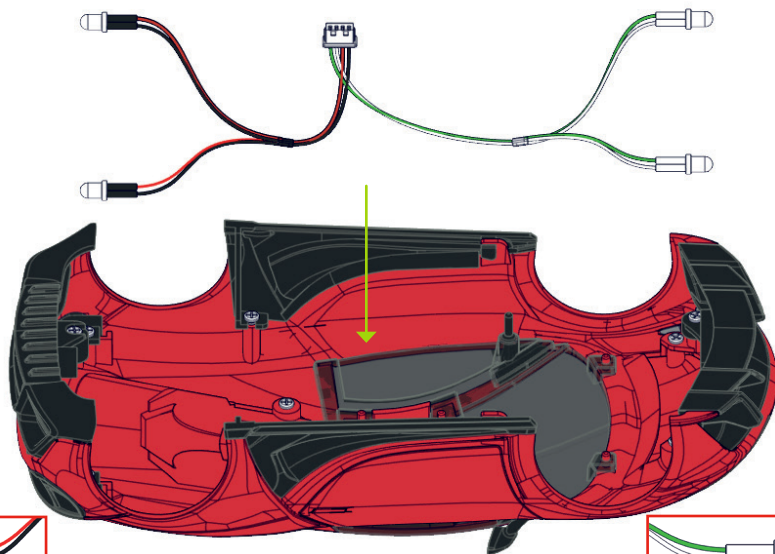

Back/ Arrière/  
Parte Trasera/ Hinten

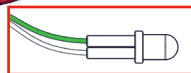

Front/ Avant/  
Parte Delantera/ Vorne

2

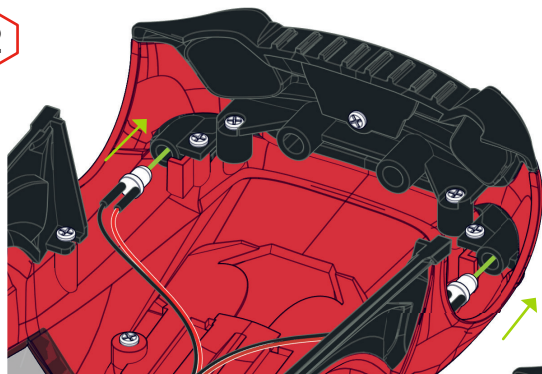

Back/ Arrière/  
Parte Trasera/ Hinten

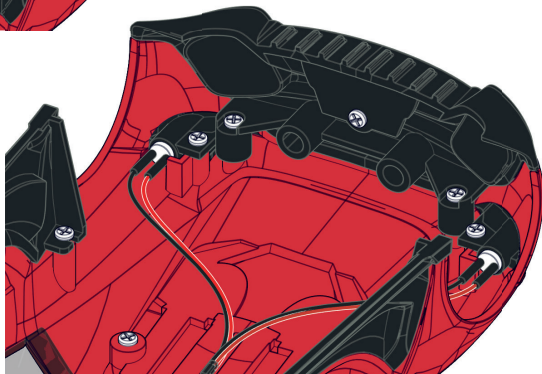

3

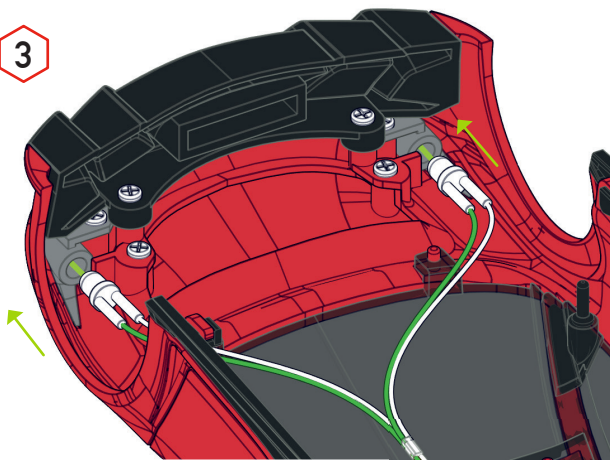

Front/ Avant/  
Parte Delantera/ Vorne

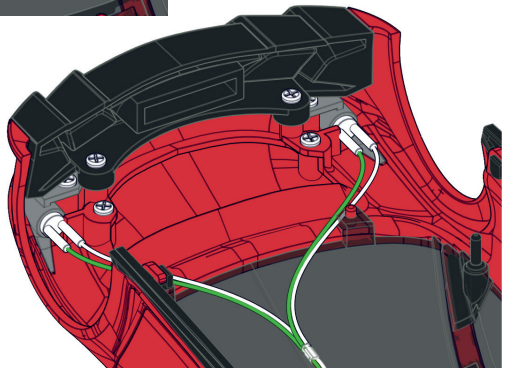

4

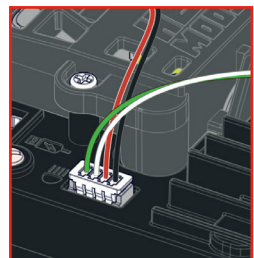
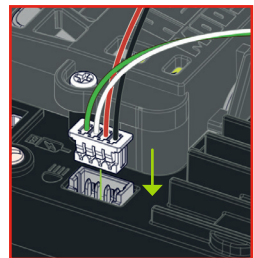
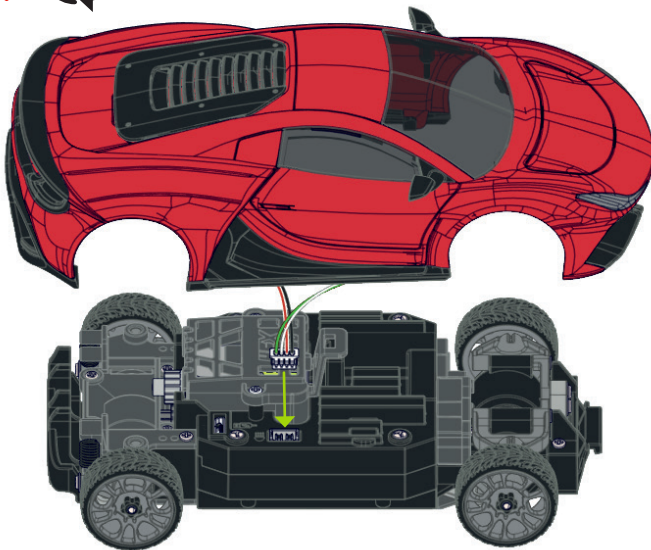

Install Underglow/ Installez Lumières Sous-Châssis/  
Instalar Iluminación Bajo Carrocería/ Unterbodenbeleuchtung installieren

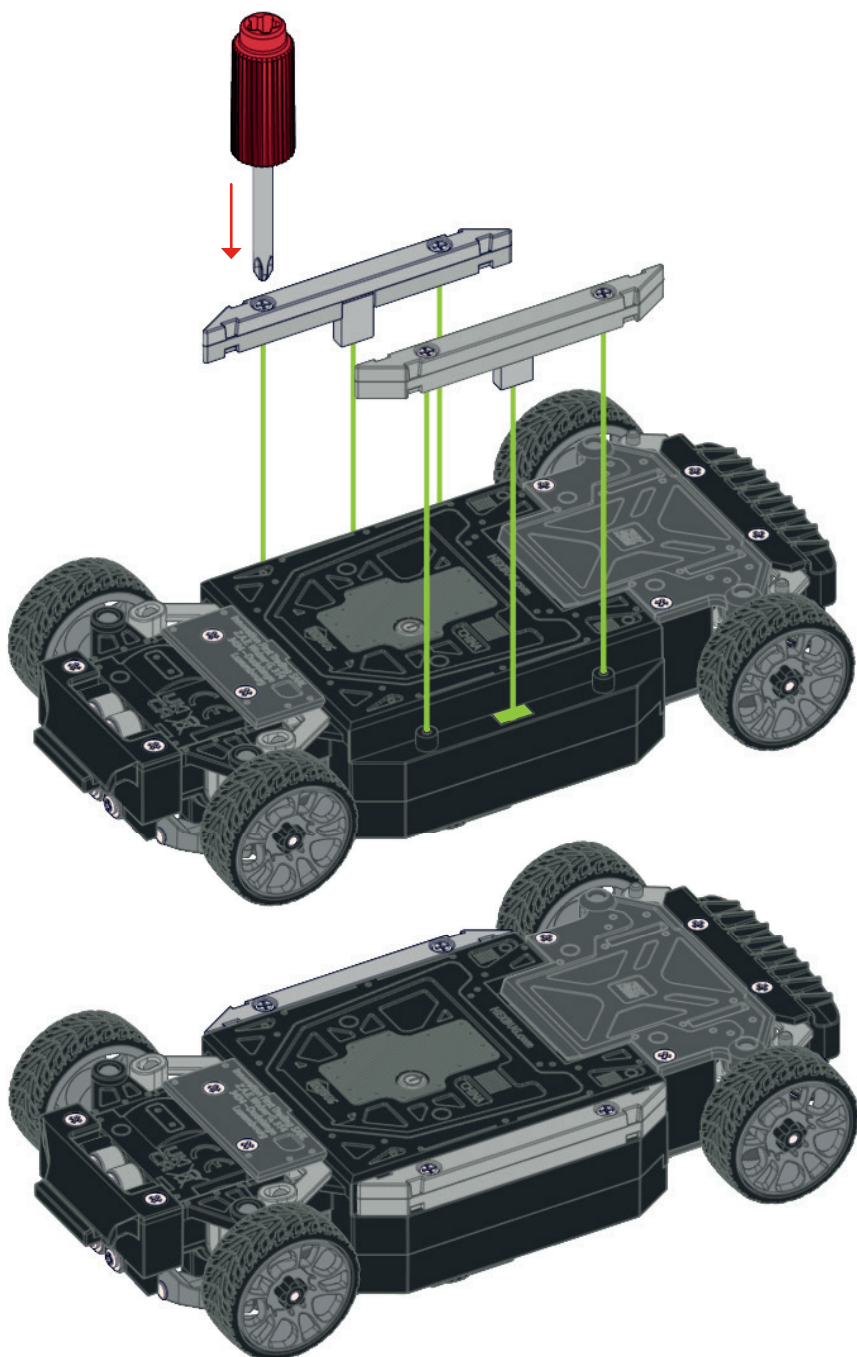



# Wheel & Tire Replacement/ Remplacement des Pneus et Roues/ Reemplazo de Ruedas y Neumáticos/ Rad- und Reifenwechsel

1 4X

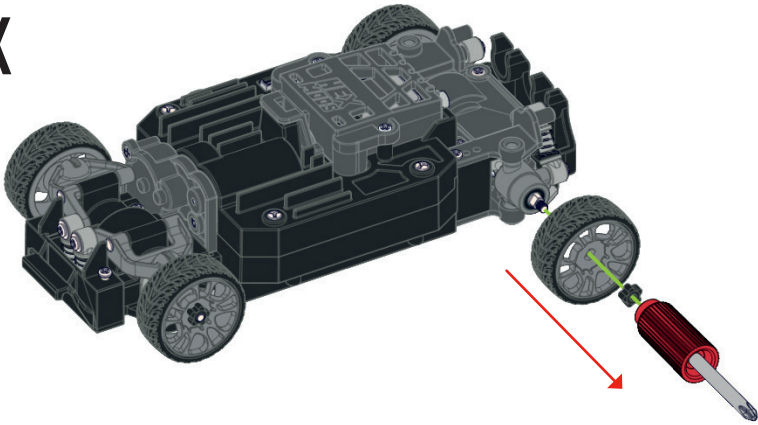

2 4X

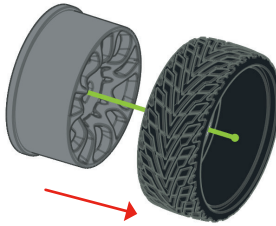

3

## Options/ Options/ Opciones/ Optionen

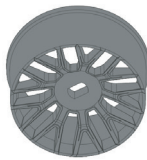

Drift/ Drift/ Deriva/ Drift

Hard Slick/ Slick Dur/  
Neumático Liso Duro/  
Harter Slick

Hard Tread/ Sculpté Dur/  
Banda de Rodadura Dura/  
Harte Lauffläche

Soft Slick/ Slick Souple/  
Neumático Liso Blando/  
Weicher Slick

Soft Tread/ Sculpté Souple/  
Banda de Rodadura Blanda/  
Weiche Lauffläche

Drift: Minimum Grip. Best on soft surfaces/  
Drift : Adhérence minimale. Idéal sur  
surfaces molles/ Deriva: Agarre Mínimo.  
Mejor en superficies blandas/ Drift:  
Minimater Grip. Am besten auf weichen  
Oberflächen.

Hard: Medium Grip. Good for all surfaces/  
Dur : Adhérence moyenne. Bon pour toutes  
les surfaces/ Duro: Agarre Medio. Bueno  
para todas las superficies/ Hart: Mittlerer  
Grip. Gut für alle Oberflächen.

Soft: Maximum Grip. Best on hard  
surfaces/ Souple: Adhérence maximale.  
Préférable sur les surfaces dures/ Suave:  
Agarre Máximo. Mejor en superficies  
duras/ Weich: Maximaler Grip.  
Am besten auf harten Oberflächen.

4 4X

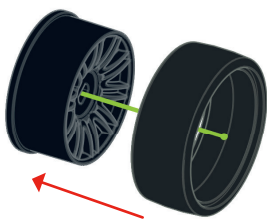

5 4X

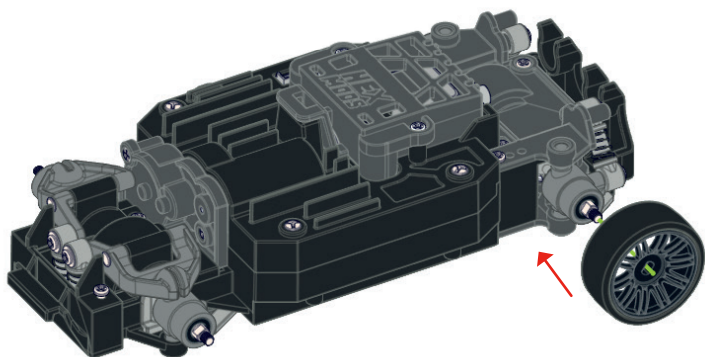
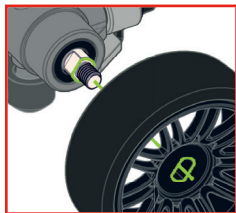

6 4X

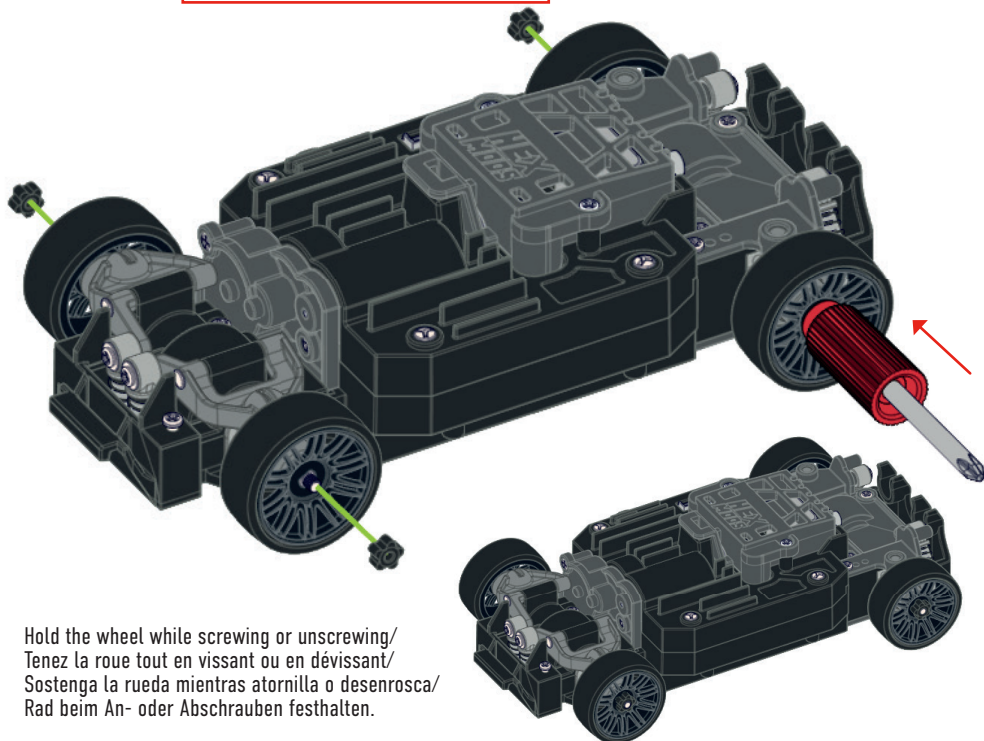
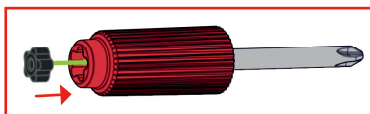

Hold the wheel while screwing or unscrewing/  
Tenez la roue tout en vissant ou en dévissant/  
Sostenga la rueda mientras atornilla o desenrosca/  
Rad beim An- oder Abschrauben festhalten.

# Replace Front Suspension/ Remplacement de la Suspension Avant/ Reemplazar Suspensión Delantera/ Vordere Aufhängung austauschen

1

2x A

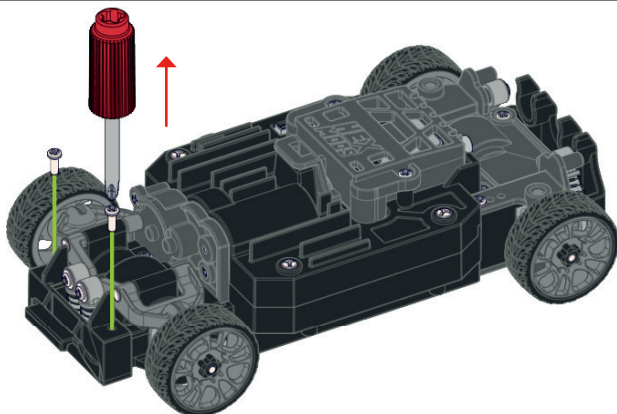

2

2x C

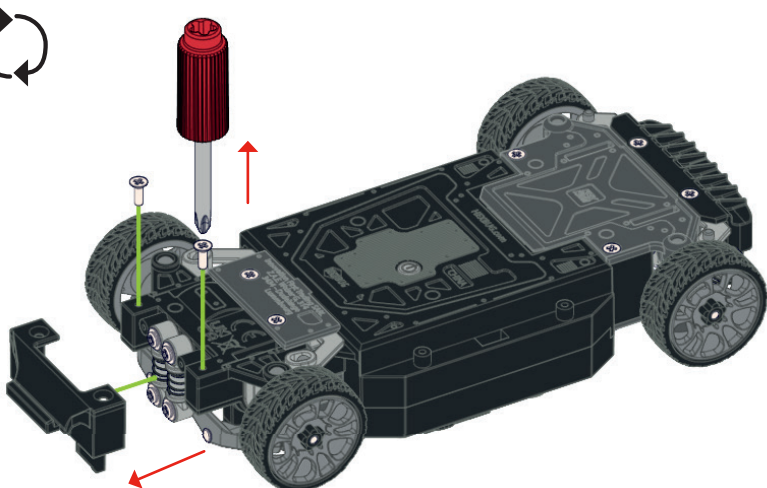

3

4x D

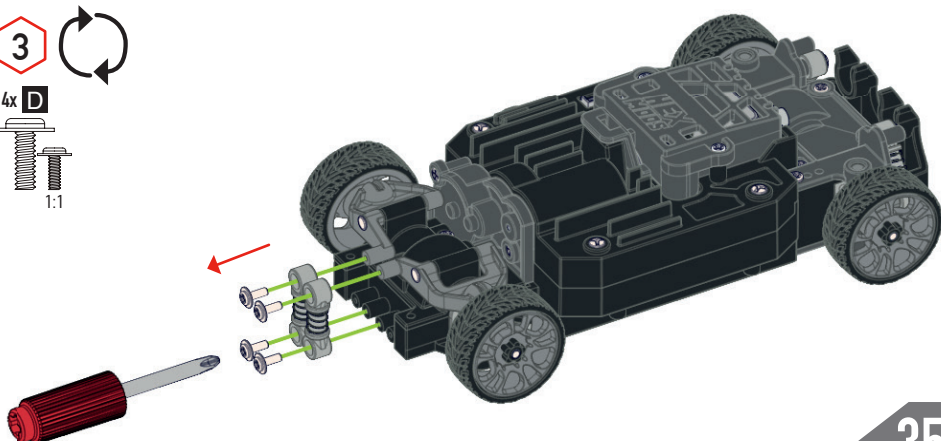

4

**Hardest Spring/ Ressort ferme/  
Amortiguador de Resorte  
Durísimo/ Härteste Feder**

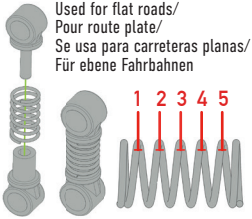

**Medium Spring/ Ressort moyen/  
Amortiguador de Resorte  
Mediano/ Mittelharte Feder**

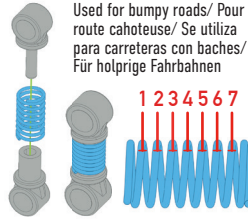

**Soft Spring/ Ressort souple/  
Resorte Blando/ Weiche Feder**

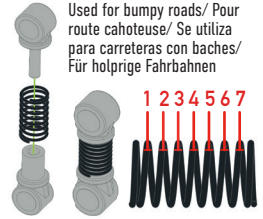

## Orientation Options/ Options d'orientation/ Opciones de Orientación/ Ausrichtungsoptionen

**Less Force/ Moins de Force/  
Menos fuerza/ Weniger Federkraft**

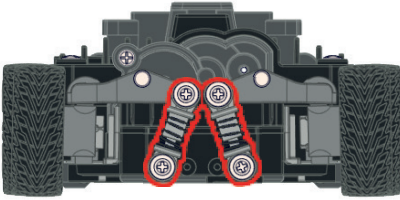

**More Force/ Plus de Force/  
Más fuerza/ Mehr Federkraft**

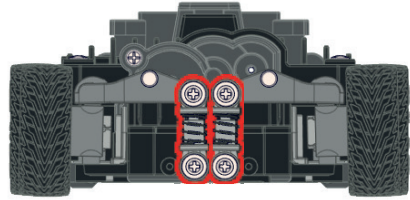

5

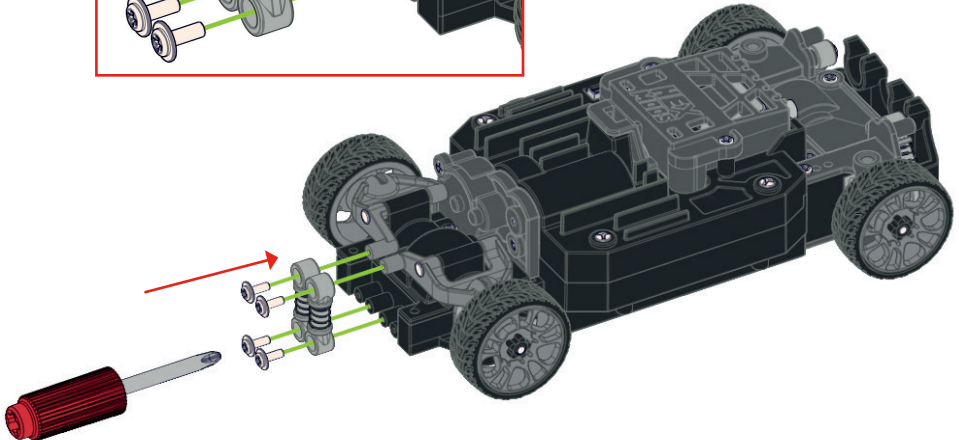
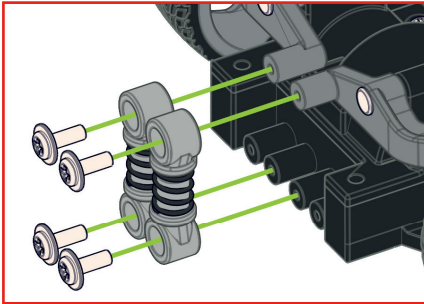

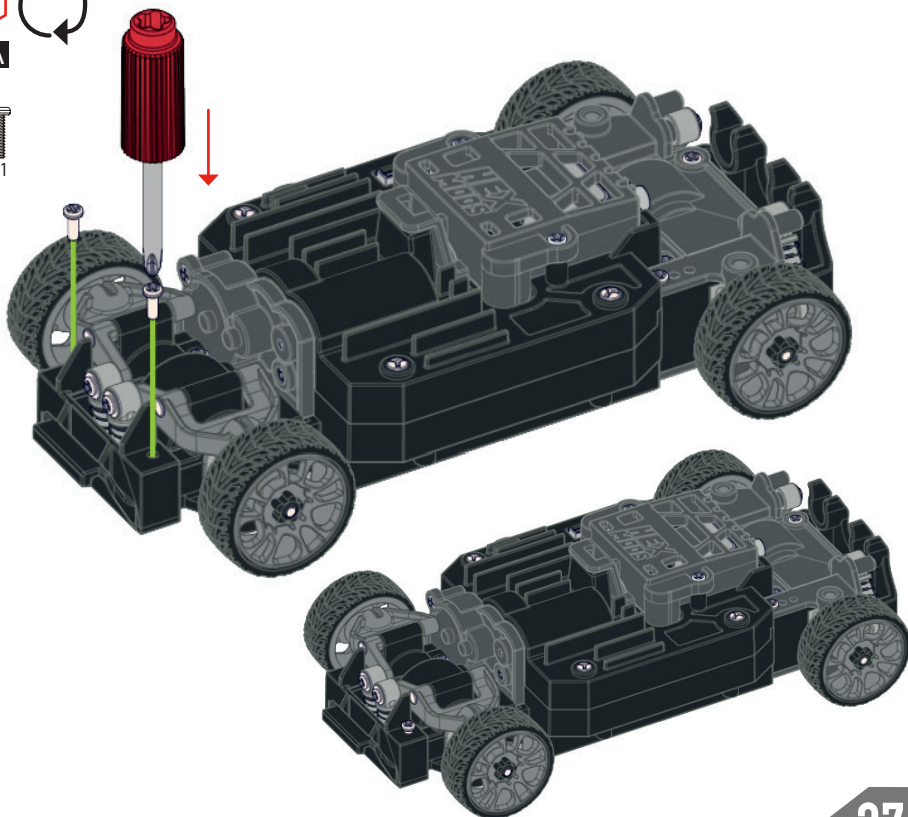
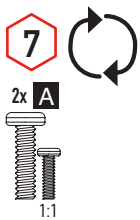
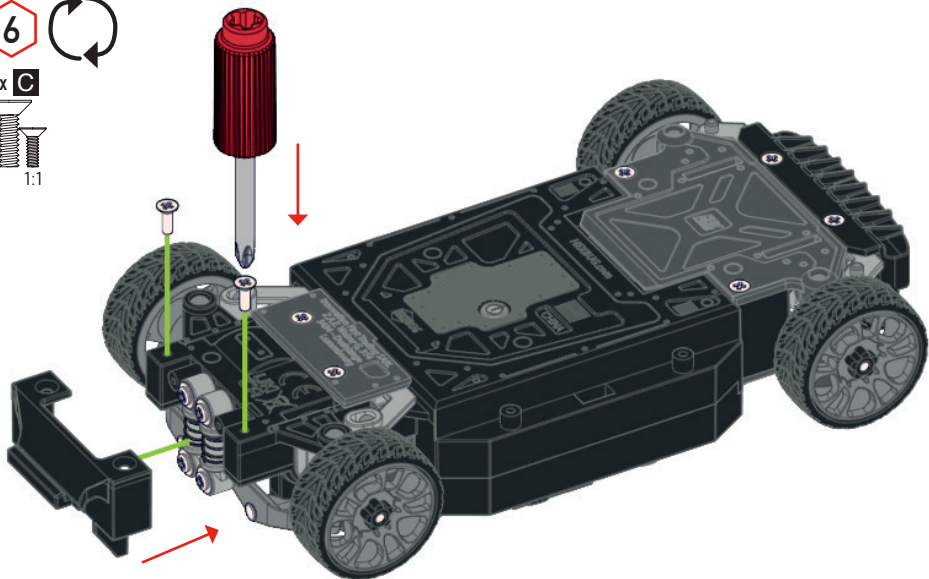
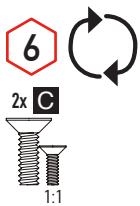

# Replace Rear Suspension/ Remplacement de la Suspension Arrière/ Reemplazar Suspensión Trasera/ Hintere Aufhängung austauschen

1

2x C

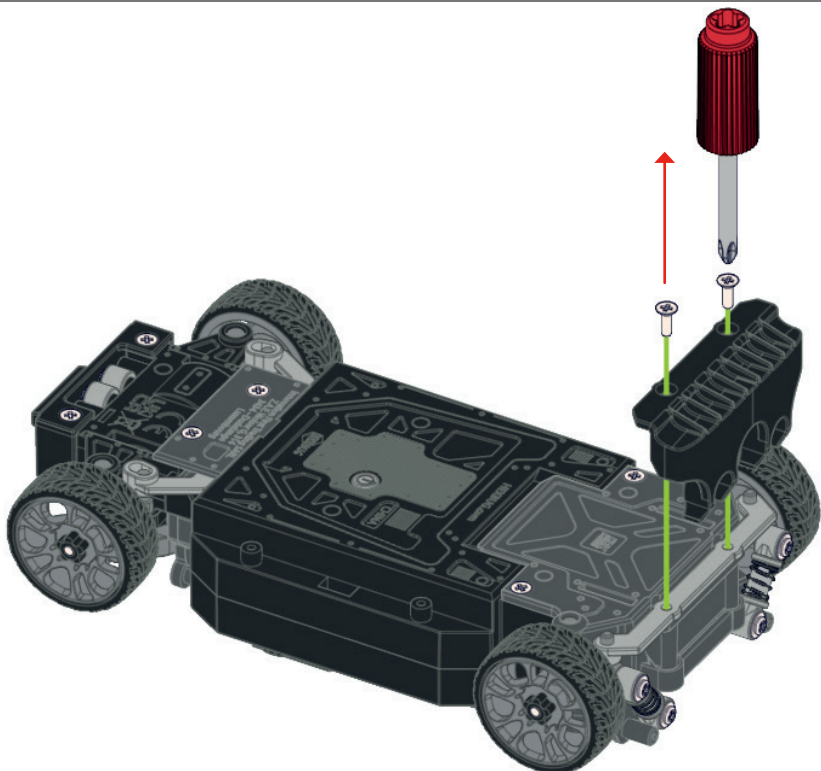

2

4x D

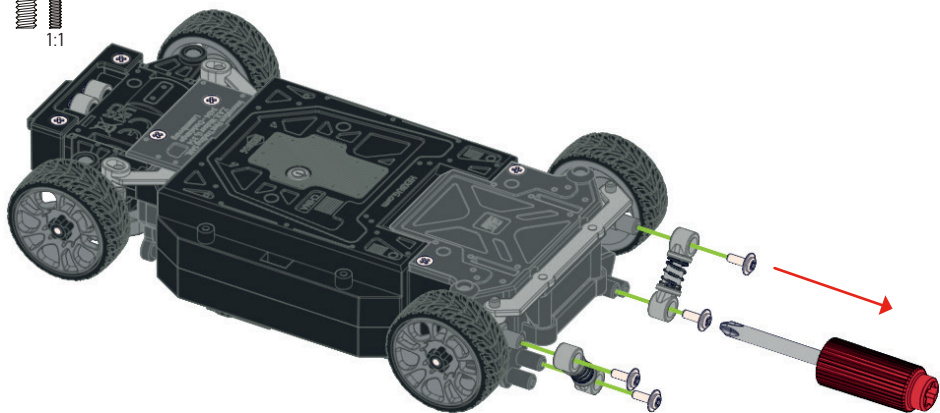

**Hardest Spring/ Ressort ferme/  
Amortiguador de Resorte Durísimo/  
Härteste Feder**

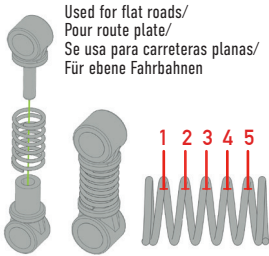

Used for flat roads/  
Pour route plate/  
Se usa para carreteras planas/  
Für ebene Fahrbahnen

**Medium Spring/ Ressort moyen/  
Amortiguador de Resorte Mediano/  
Mittelharte Feder**

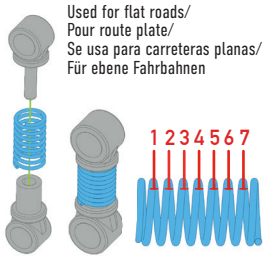

Used for flat roads/  
Pour route plate/  
Se usa para carreteras planas/  
Für ebene Fahrbahnen

**Soft Spring/ Ressort souple/  
Resorte Blando/ Weiche Feder**

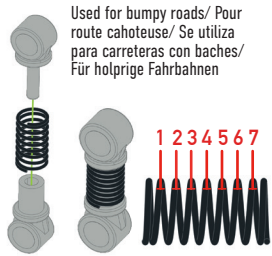

Used for bumpy roads/ Pour route cahoteuse/ Se utiliza para carreteras con baches/ Für holprige Fahrbahnen

**Orientation Options/ Options d'orientation/ Opciones de Orientación/ Ausrichtungsoptionen**

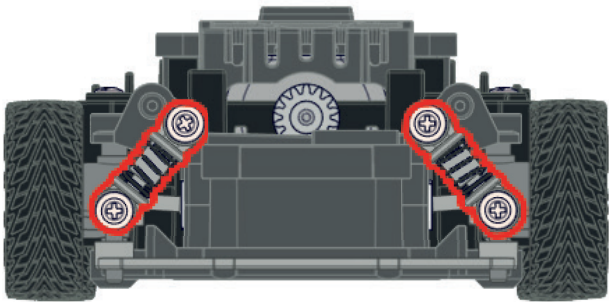

**Less Force/ Moins de  
Force/ Menos fuerza/  
Weniger Federkraft**

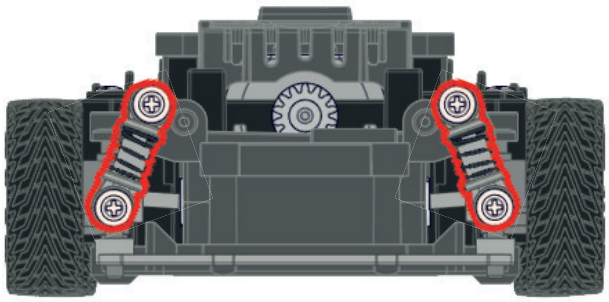

**More Force/ Plus de  
Force/ Más fuerza/  
Mehr Federkraft**

**4**4x **D**

Hold the bar while assembling the springs to the chassis/  
Tenez la barre tout en assemblant les ressorts au châssis/  
Sostenga la barra mientras ensambla los spings al chasis/  
Teile bei Montage der Federn am Fahrgestell festhalten.

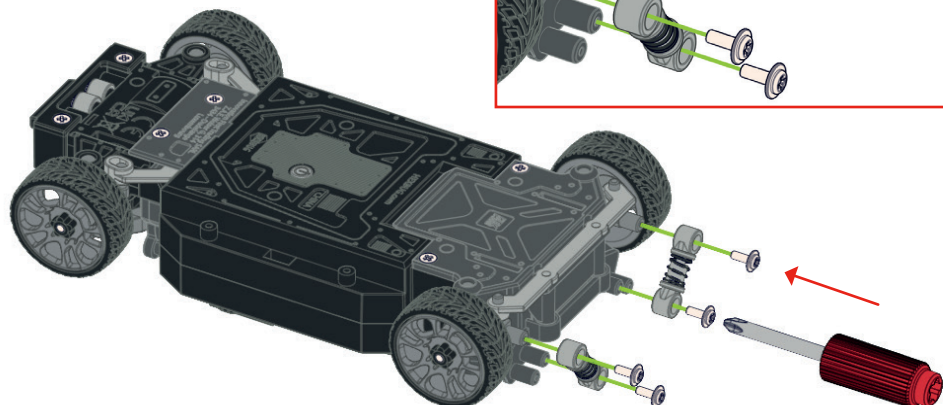
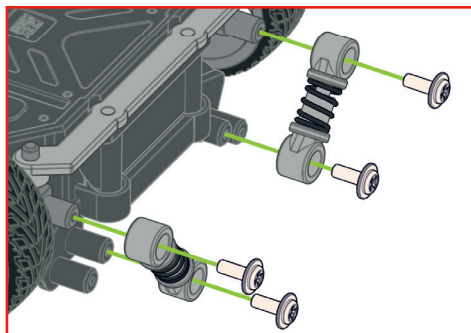
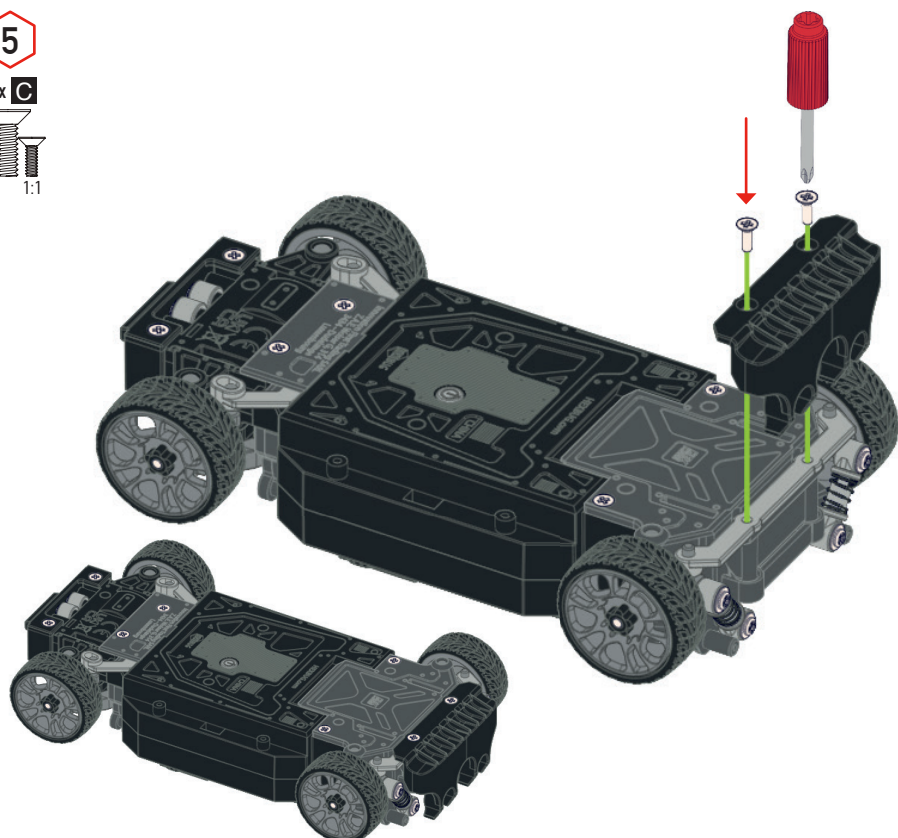
**5**2x **C**



# Change Speed/ Changement de Vitesse/ Cambiar Velocidad/ Geschwindigkeit ändern

1

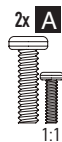

Push in  
Appuyez  
Empujar  
Einschieben

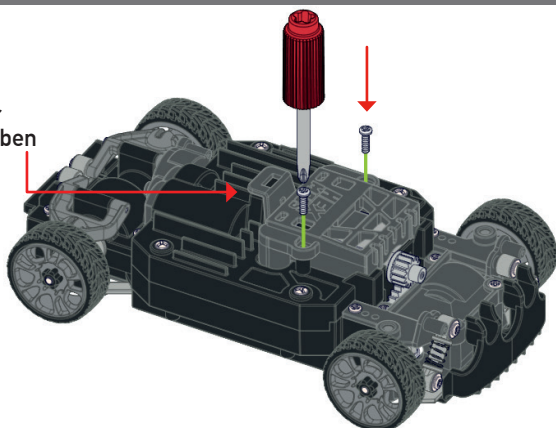

2

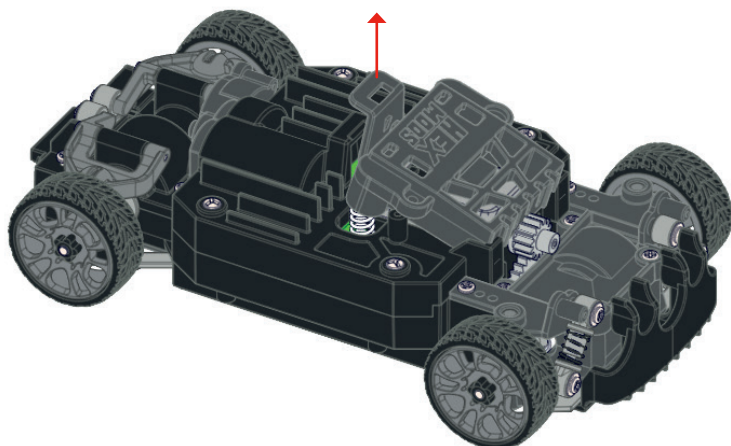

3

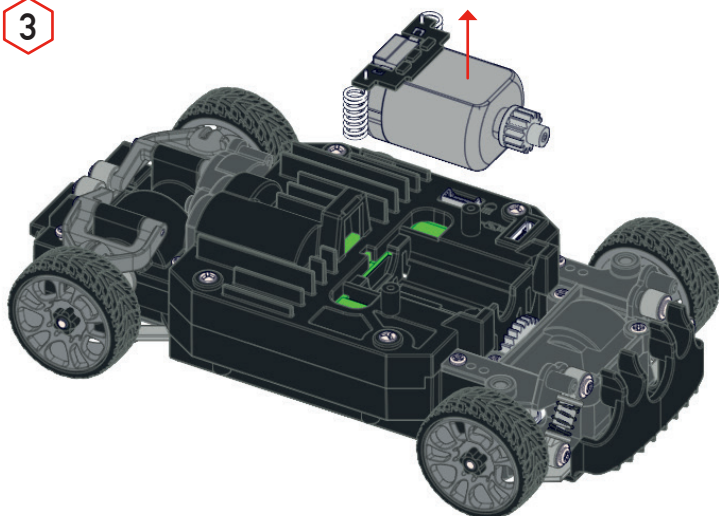

**CAUTION:** Motor may be hot to the touch. Take caution when touching or changing out motor after continuous play.

**ATTENTION:** Le moteur peut être chaud ou toucher. Soyez prudent lorsque vous changez ou touchez le moteur après une utilisation continue.

**PRECAUCIÓN:** El motor puede estar caliente al tacto. Tenga cuidado al tocar o cambiar el motor después de un juego continuo.

**VORSICHT:** Der Motor könnte heiß sein, wenn er nach ständigem Spiel berührt oder ausgewechselt wird.

4

2x A

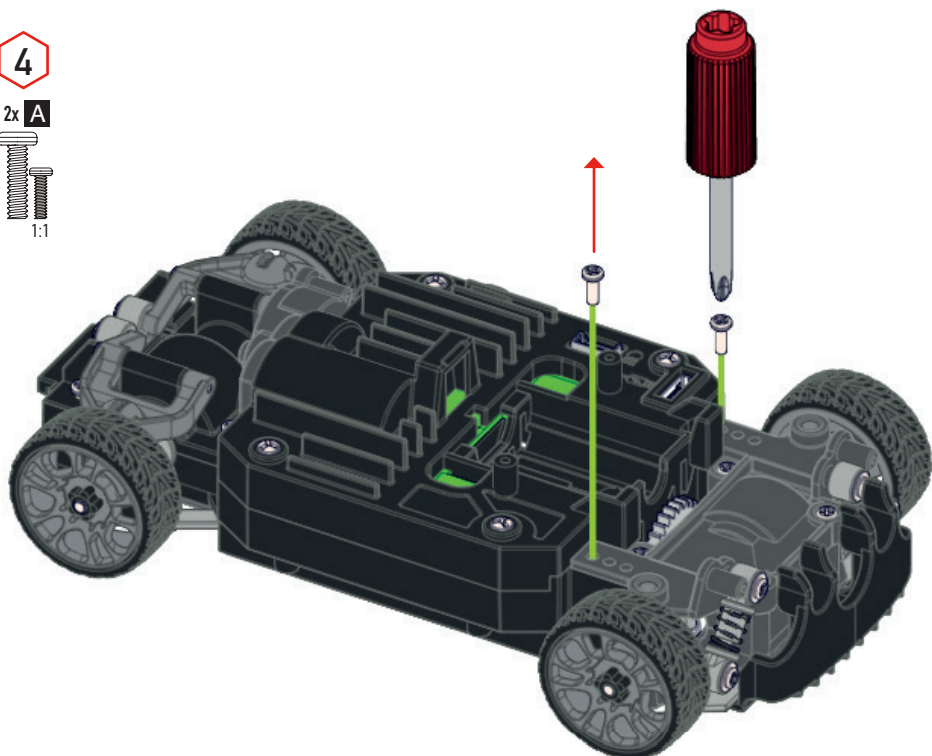

5



2x C

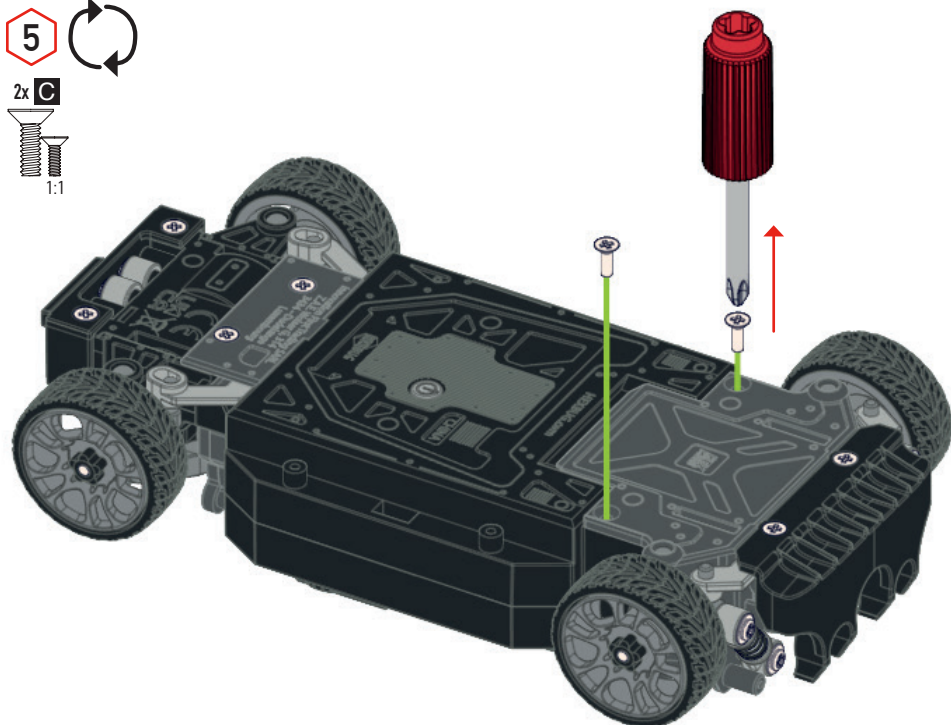

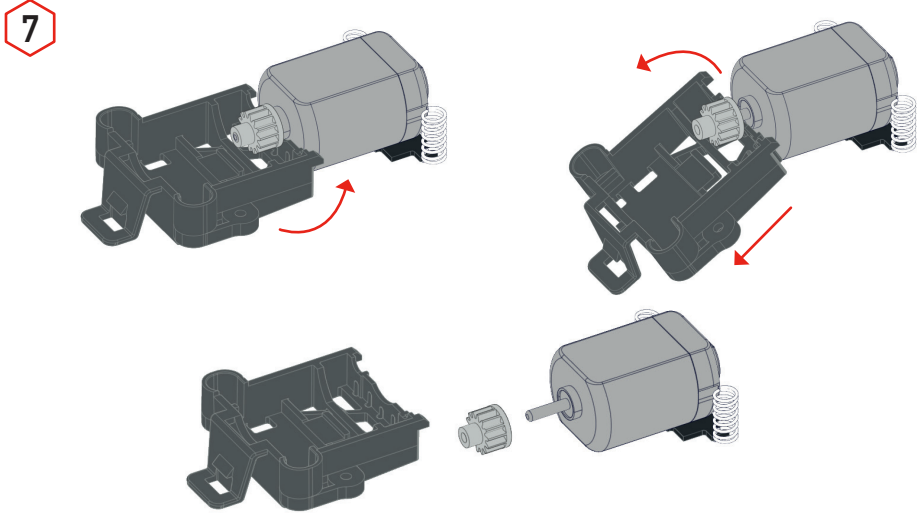
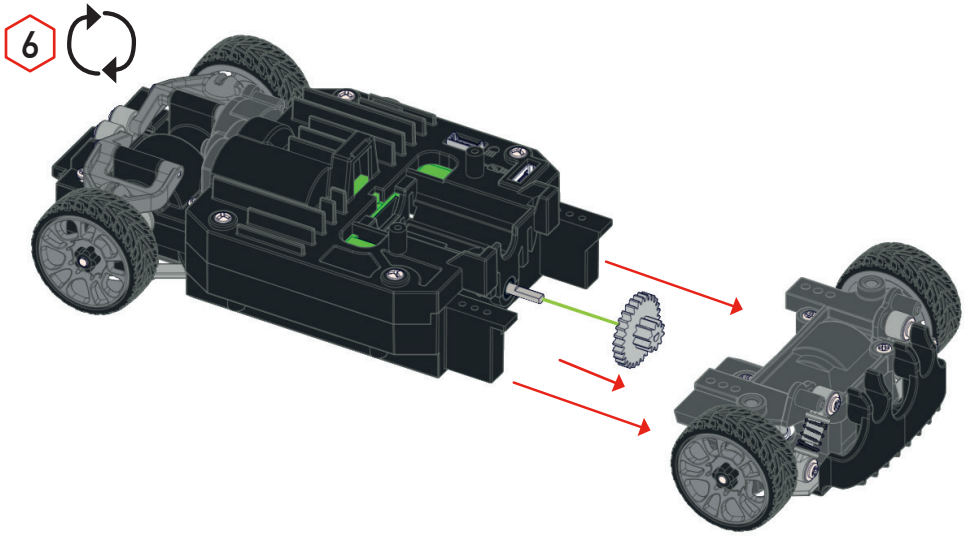

8 Options/ Options/ Opciones/ Optionen

Speed/ Vitesse/ Velocidad/ Geschwindigkeit

Acceleration/ Accélération/ Acelerar/ Beschleunigung

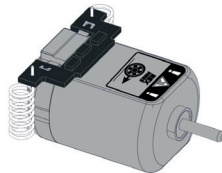
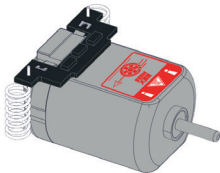

9

**Gear Options/ Options de Vitesses/ Opciones de Cambio de Velocidad/ Getriebe-Optionen**

**Speed/ Vitesse/ Velocidad/ Geschwindigkeit**

**Balanced/ Équilibré/ Balanceado/ Ausgewogen**

**Acceleration/ Accélération/ Acelerar/ Beschleunigung**

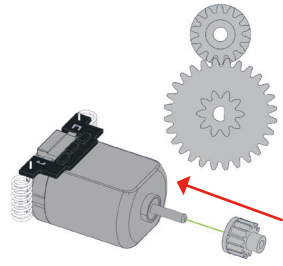
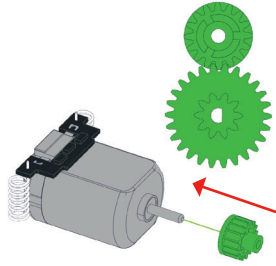
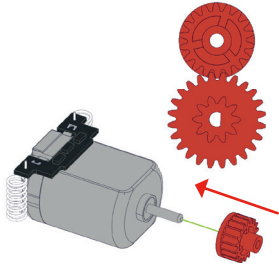

10

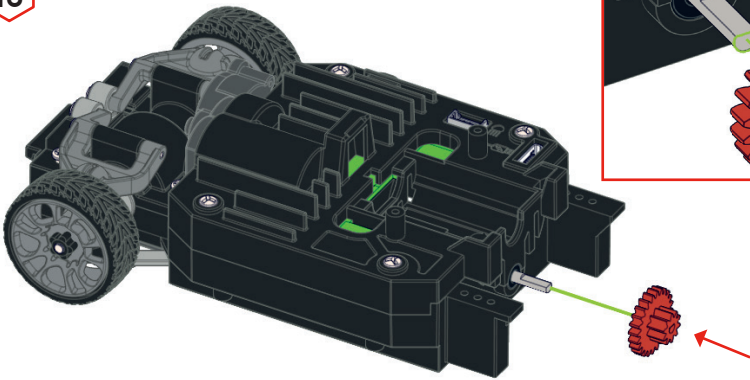

11

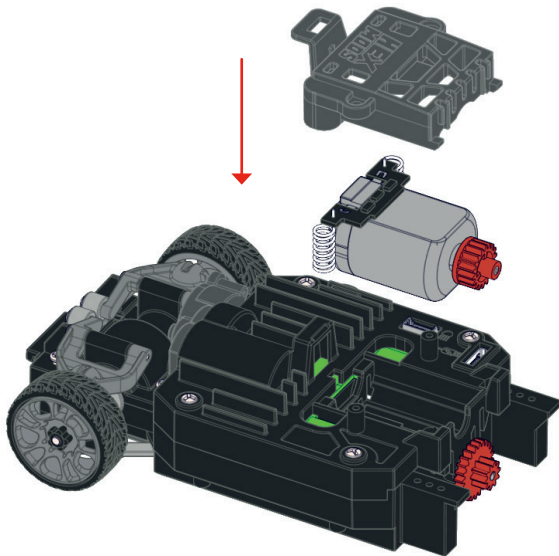

12

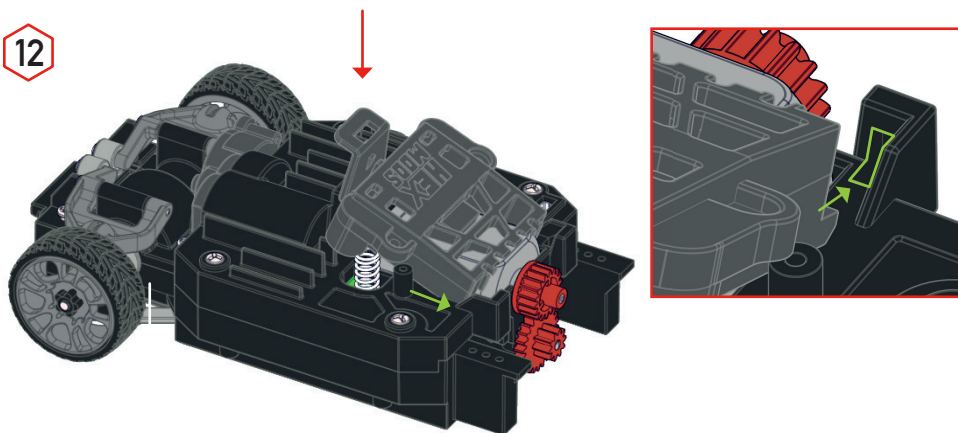

13

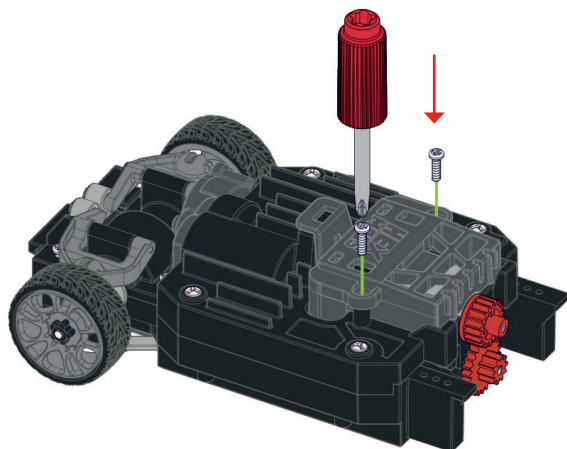
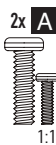

14

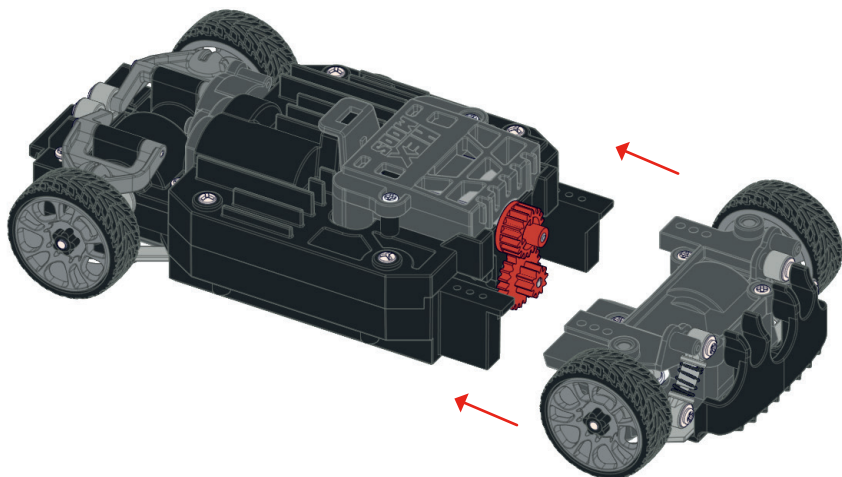

15

2x A

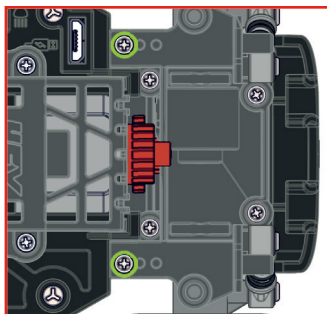
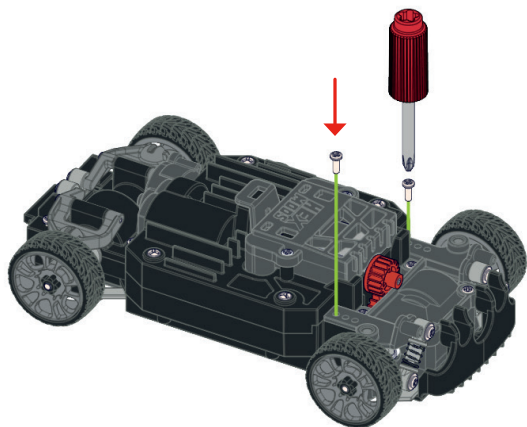

16

2x C

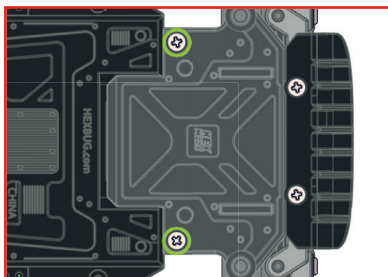
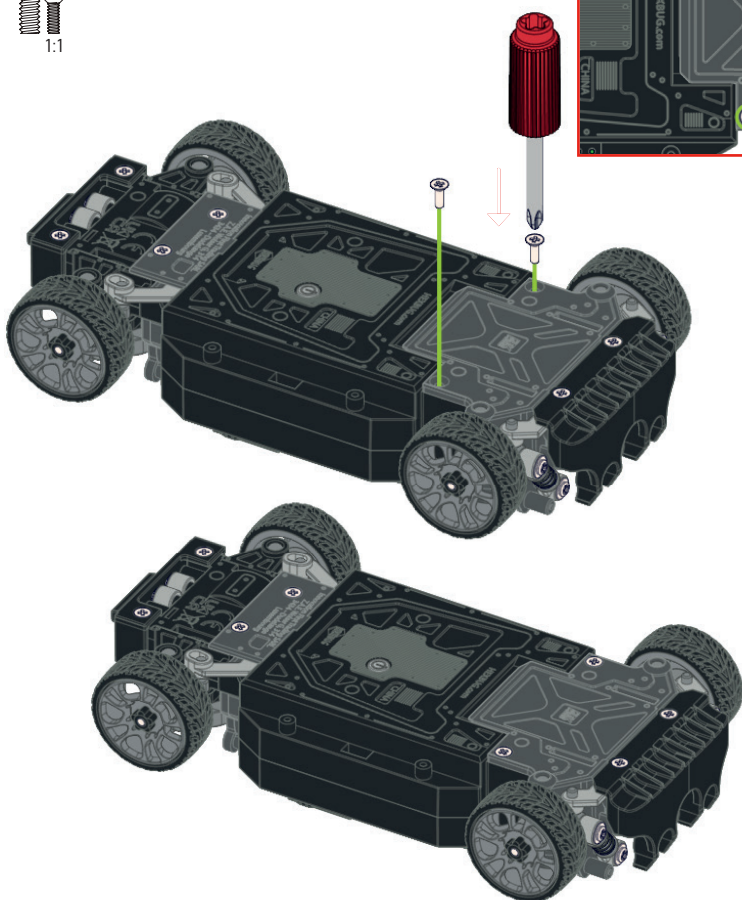

# Steering Link/ Barre de Direction/ Enlace de Dirección/ Spurstange

1

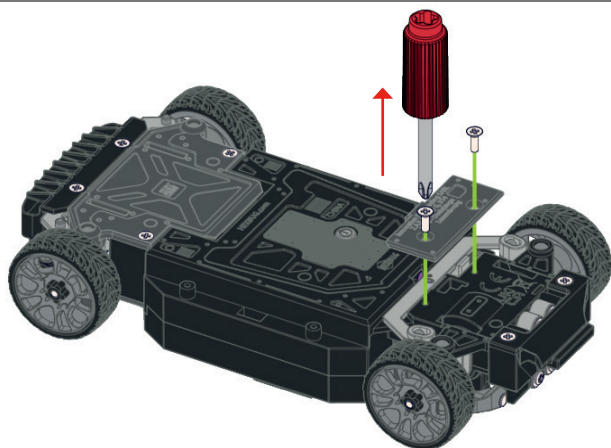
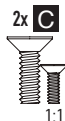

2

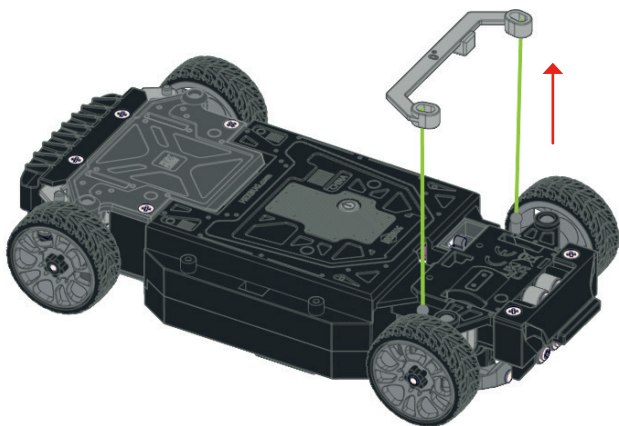

3

## Options/ Options/ Opciones/ Optionen

Toe in (a positive number) is better for a track that has more straights/  
Un chiffre positif (angle d'ouverture) est préférable sur une piste droite/  
Un número positivo (puntera hacia afuera) es mejor para una pista que tiene más rectas/  
Vorspur (eine positive Zahl) ist besser für eine Strecke, die mehr Geraden hat.



Toe out (a negative number) is better for a track that has more turns/  
Un chiffre négatif (angle de pincement) est préférable sur une piste avec virages/  
Un número negativo (convergencia) es mejor para una pista que tiene más vueltas/  
Nachspur (eine negative Zahl) ist besser für eine Strecke, die mehr Kurven hat.



4

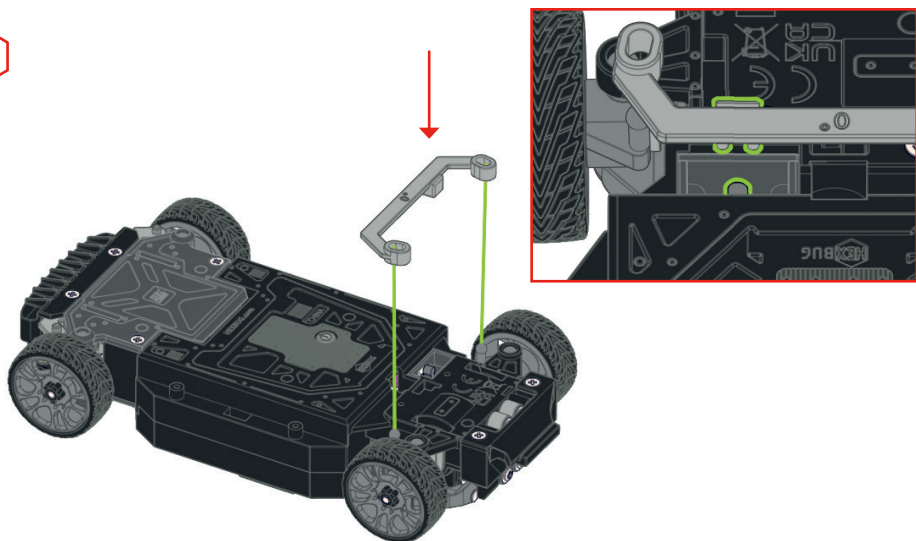

5

2x **C**  
  
1:1

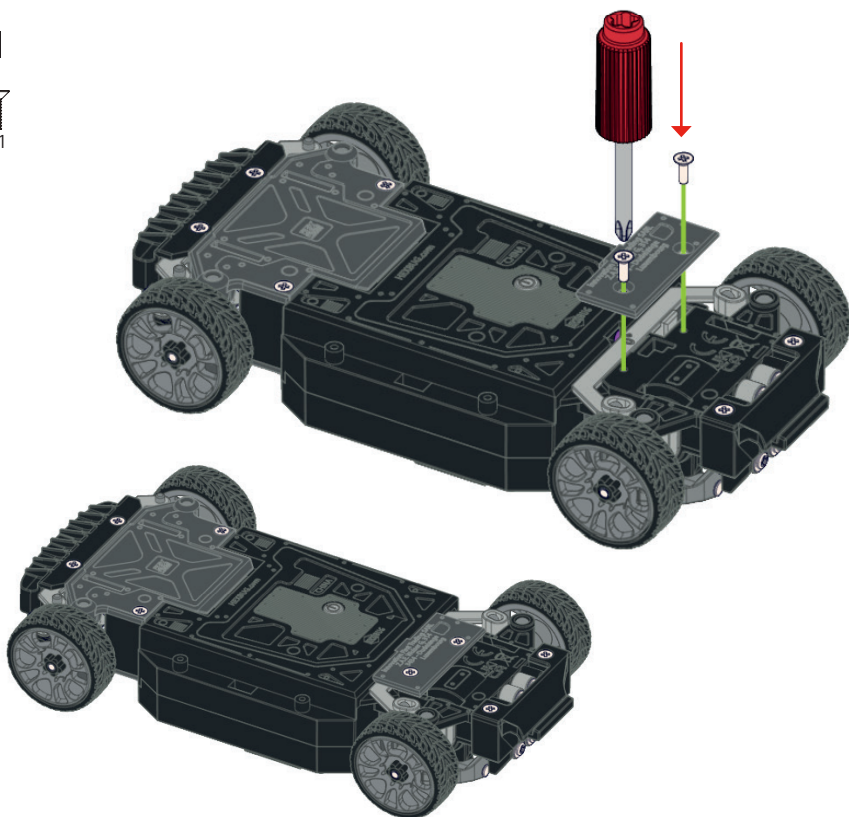



# RWD, FWD, AWD/ RWD, FWD, AWD/ Tracción Trasera, Tracción Delantera, Tracción Trasera y Delantera/ Antrieb: RWD, FWD, AWD

## Options/ Options/ Opciones/ Optionen

AWD/ AWD/ Tracción Trasera y Delantera/ AWD

Front/ Avant/  
Parte Delantera/  
Vorne

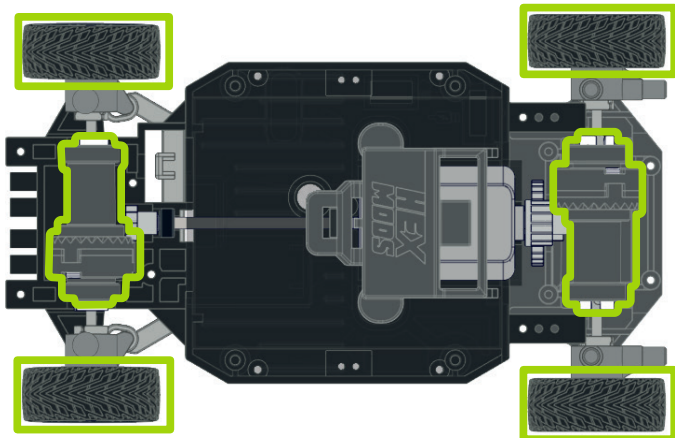

Back/ Arrière/  
Parte Trasera/ Hinten

FWD/ FWD/ Tracción Delantera/ FWD

Front/ Avant/  
Parte Delantera/  
Vorne

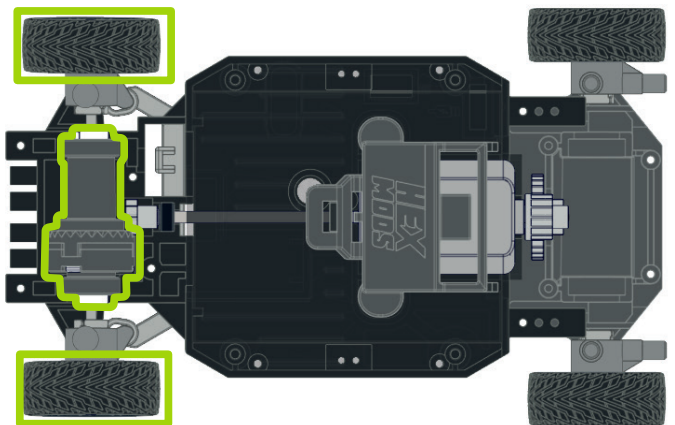

Back/ Arrière/  
Parte Trasera/ Hinten

RWD/ RWD/ Tracción Trasera/ RWD

Front/ Avant/  
Parte Delantera/  
Vorne

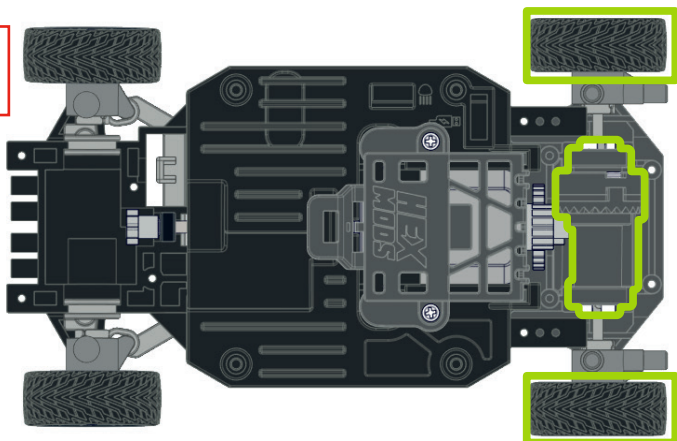

Back/ Arrière/  
Parte Trasera/ Hinten

# Remove Rear Differential/ Retirer le différentiel arrière/ Retire el Diferencial Trasero/ Hinteres Differential ausbauen

1

2x C

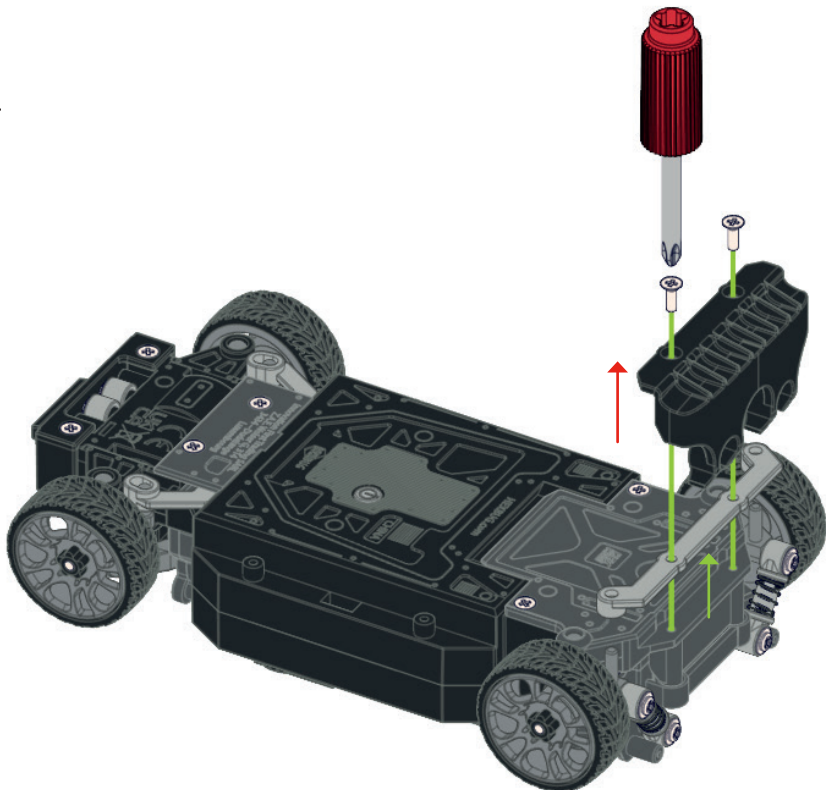

2

4x D

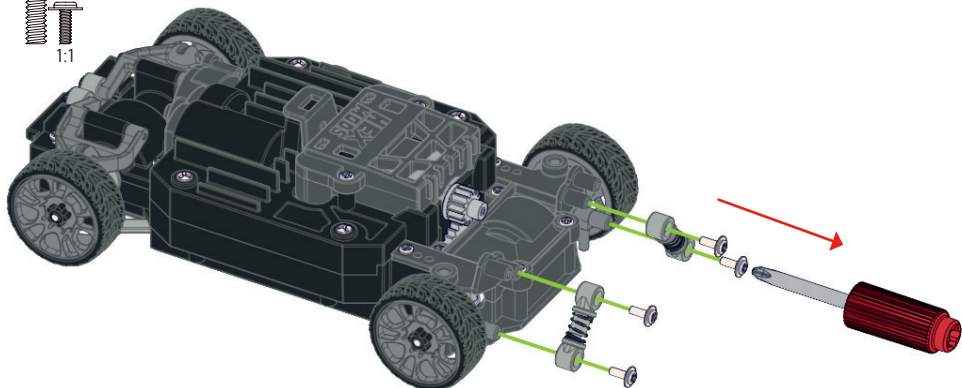

3

2x A



Push in  
Appuyez  
Empujar  
Einschieben

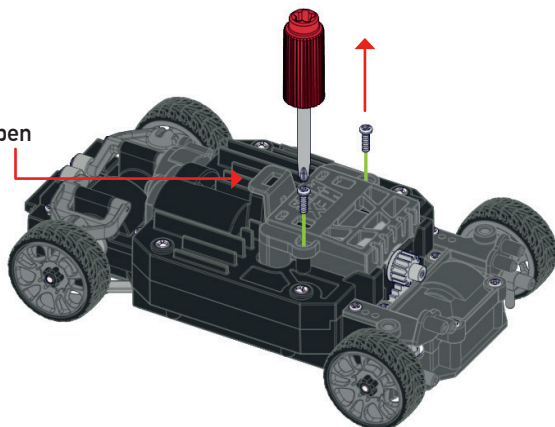

4

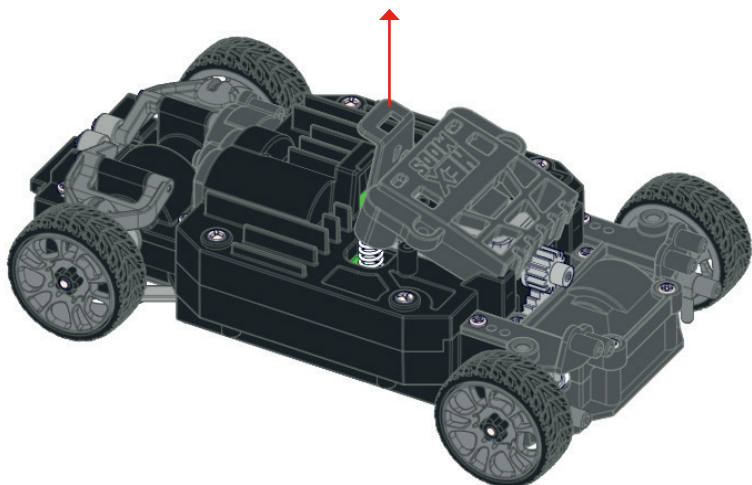

5

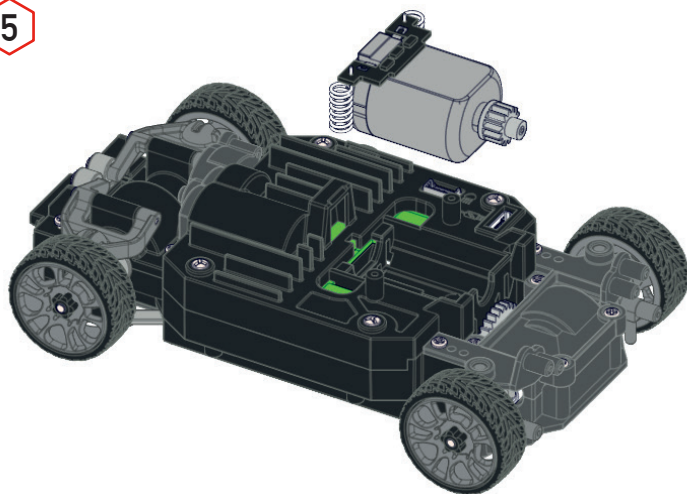

**CAUTION:** Motor may be hot to the touch. Take caution when touching or changing out motor after continuous play.

**ATTENTION:** Le moteur peut être chaud ou toucher. Soyez prudent lorsque vous changez ou touchez le moteur après une utilisation continue.

**PRECAUCIÓN:** El motor puede estar caliente al tacto. Tenga cuidado al tocar o cambiar el motor después de un juego continuo.

**VORSICHT:** Der Motor könnte heiß sein, wenn er nach ständigem Spiel berührt oder ausgewechselt wird.

6

6x A

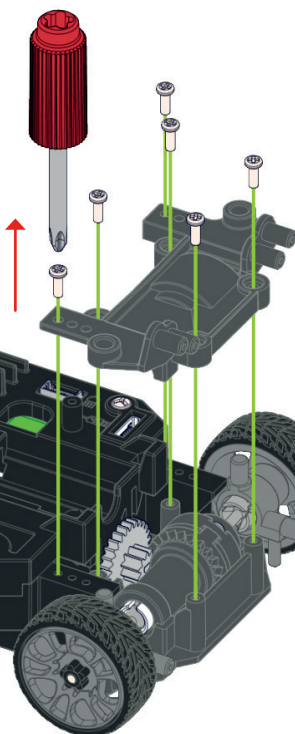
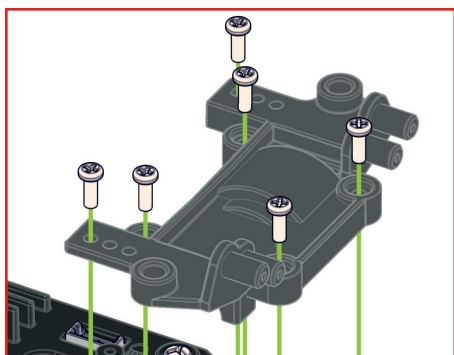

7

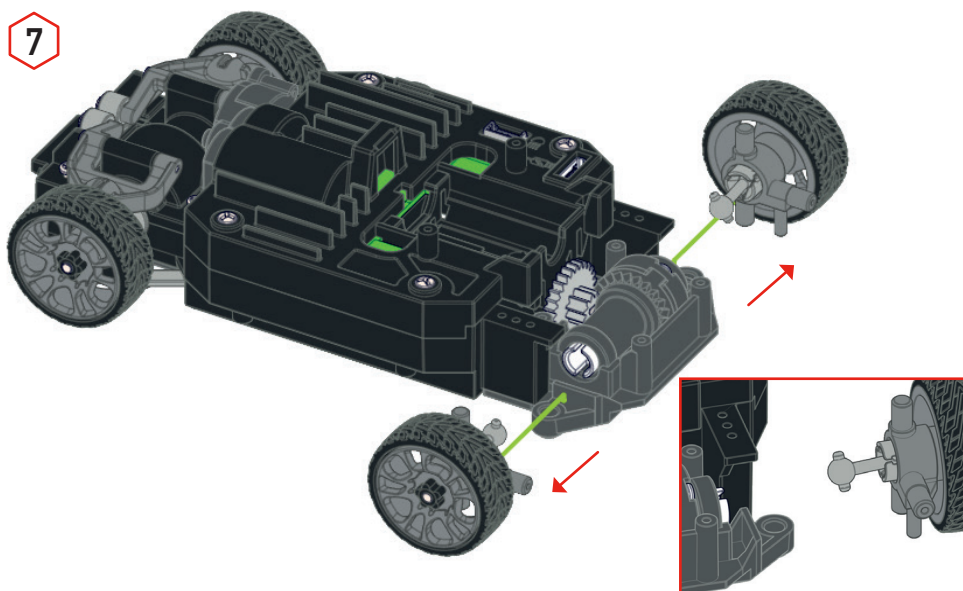

8 2X

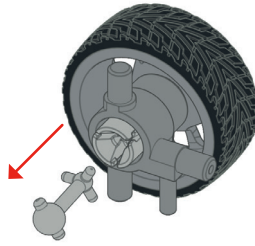

9

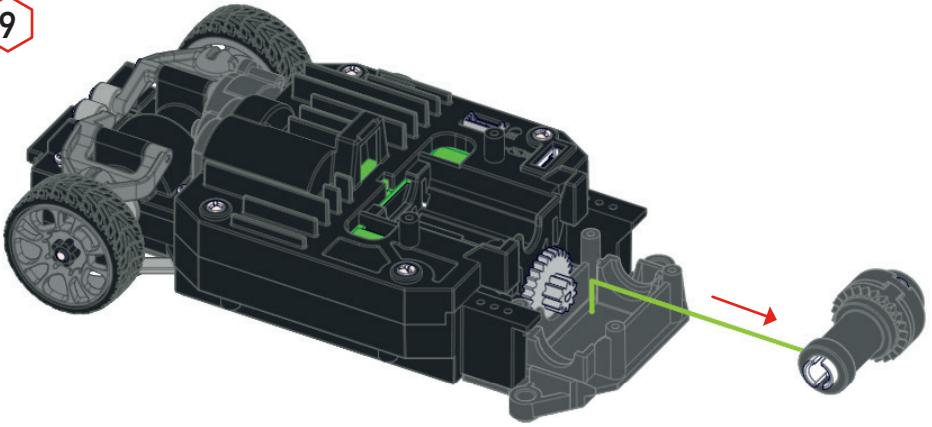

10

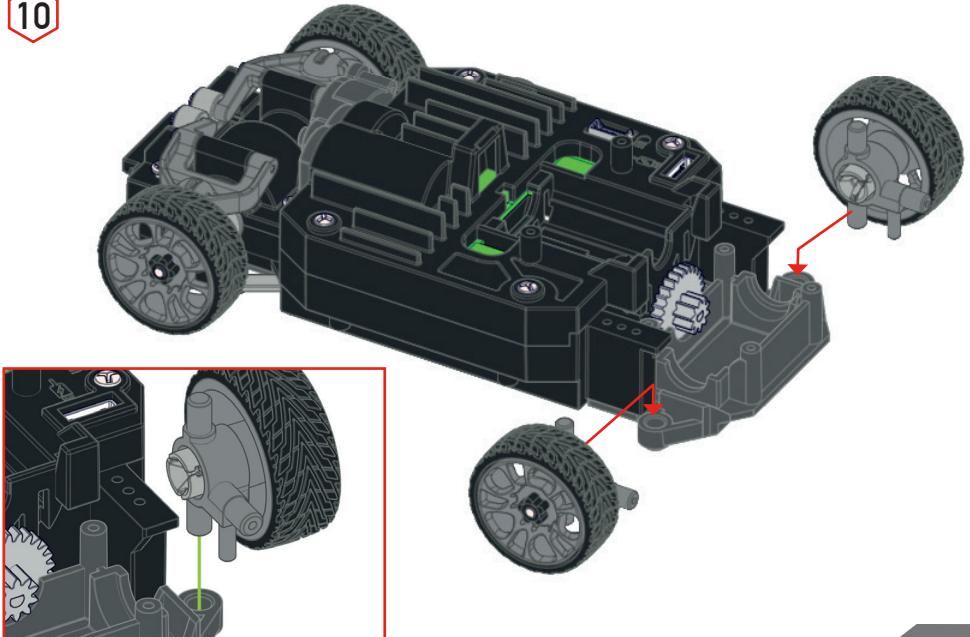

11

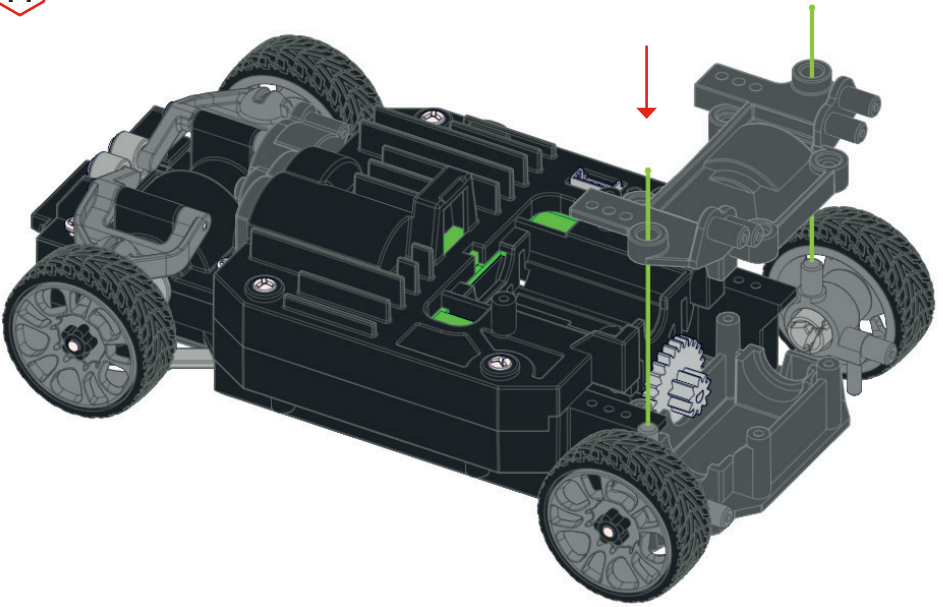

12

6x A  
1:1

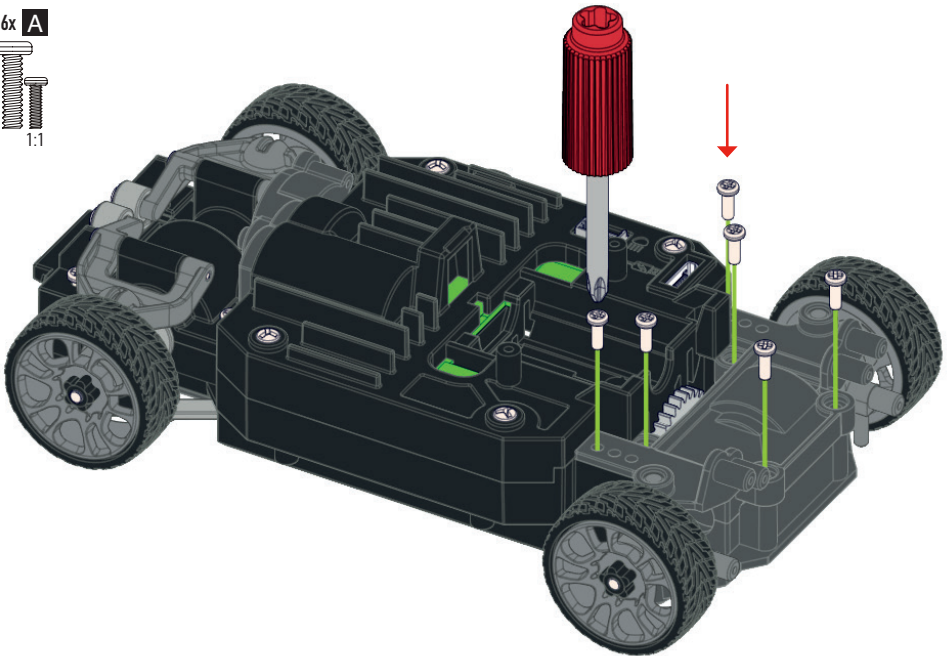

13

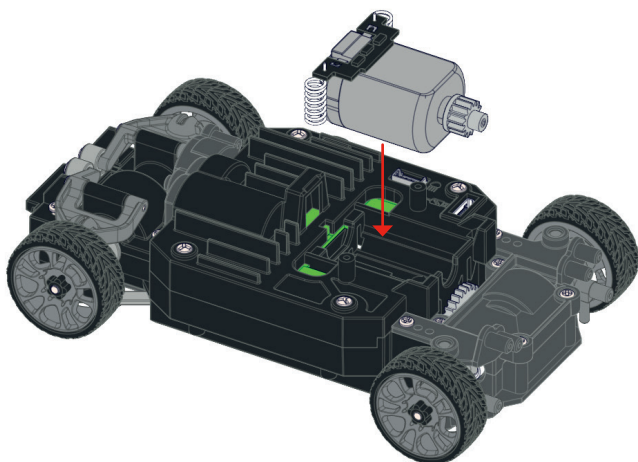

14

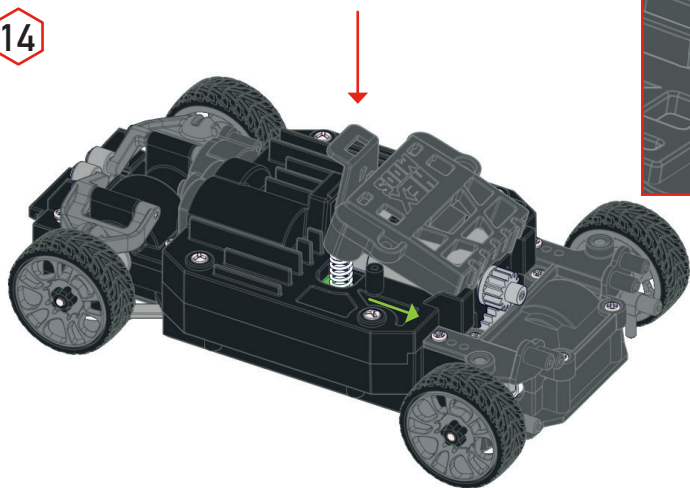

15

2x A  
1:1

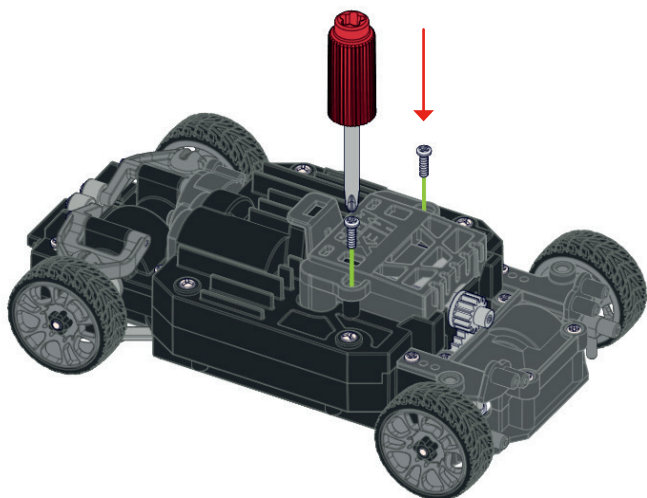

16

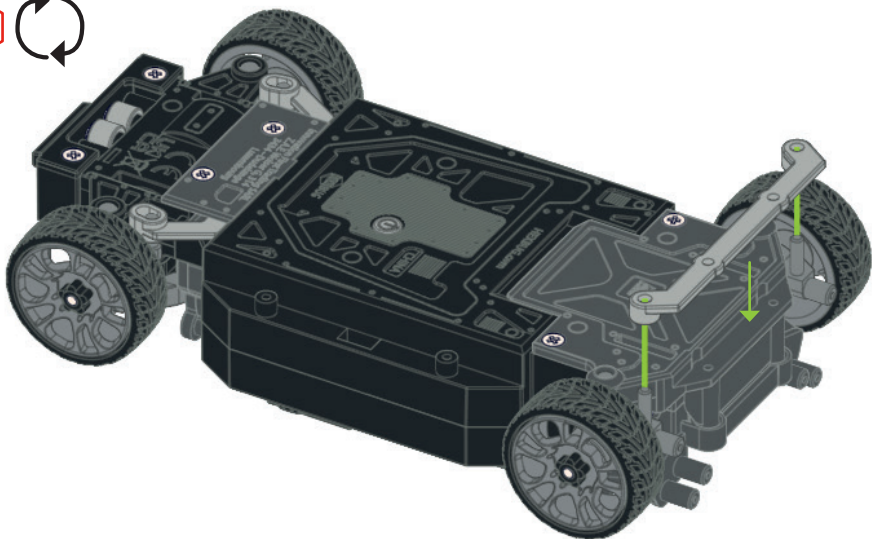

17

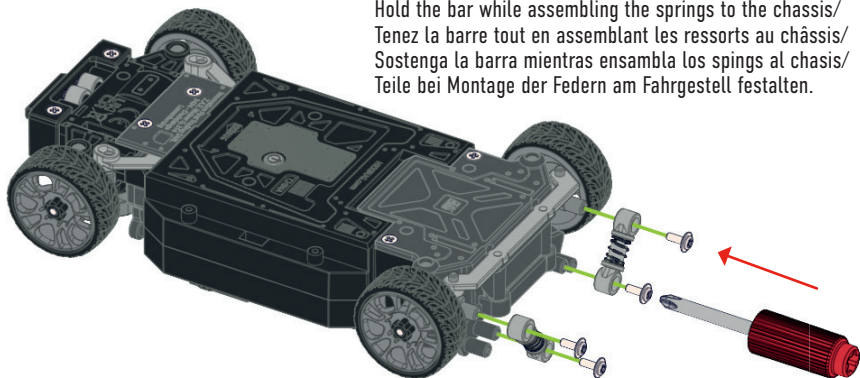
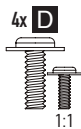

18

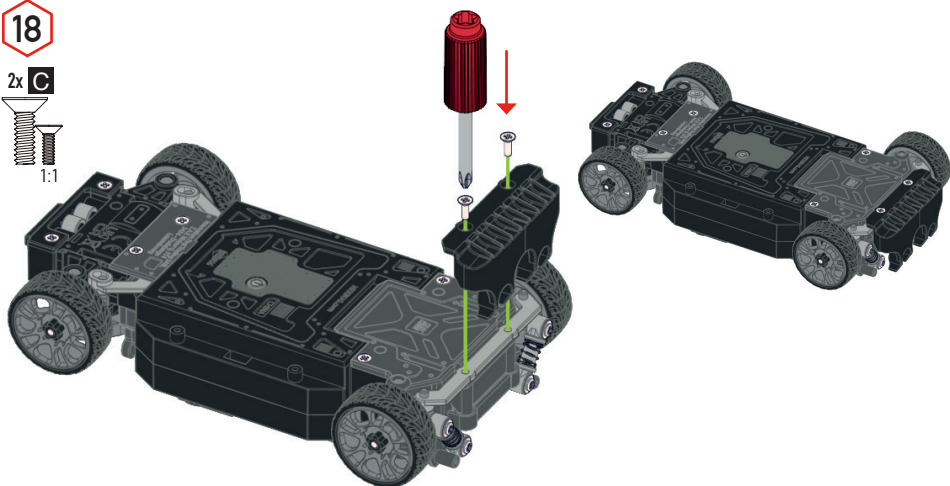
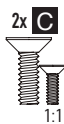



# Install Front Differential/ Installer le Différentiel Avant/ Instale el Diferencial Delantero/ Vorderes Differential installieren

1

2x A

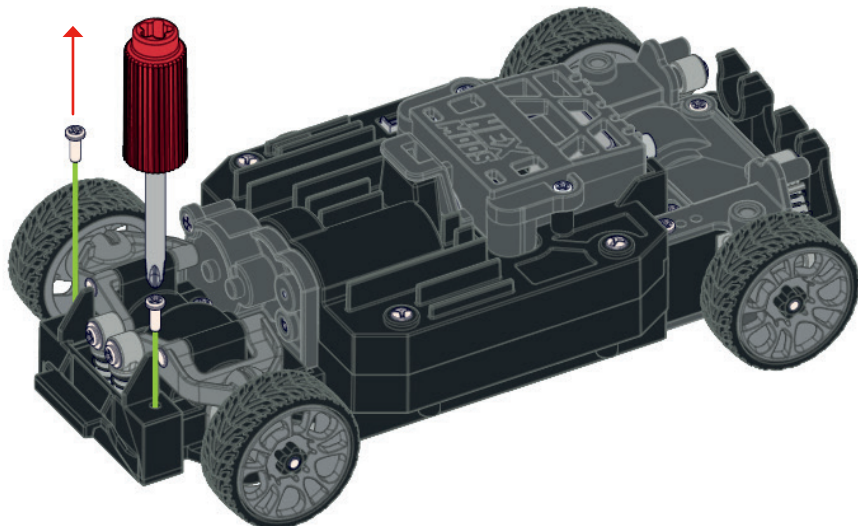

2

2x C

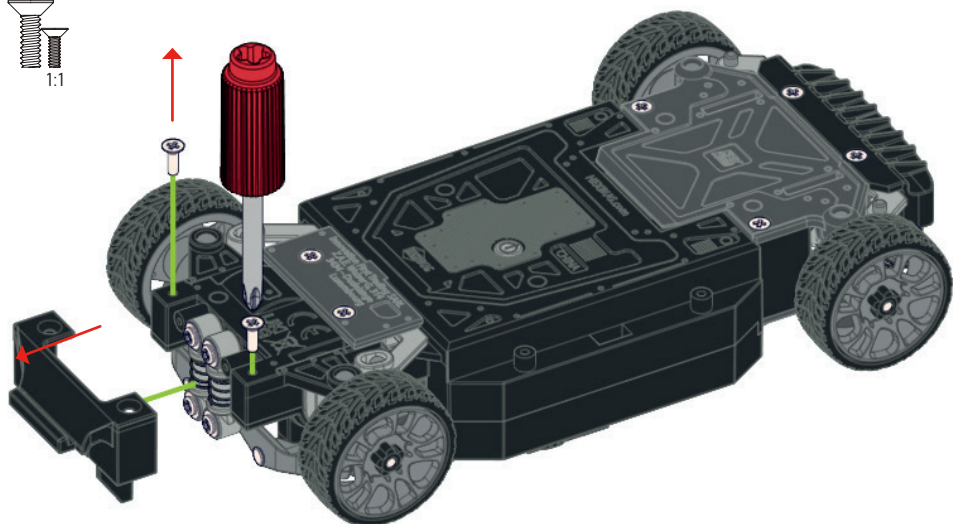

3



4x D  
1:1

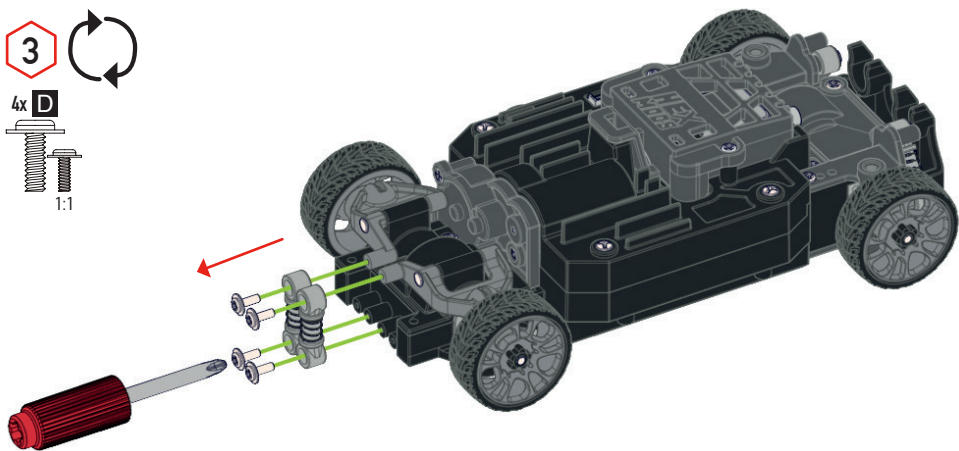

4

2x A  
1:1

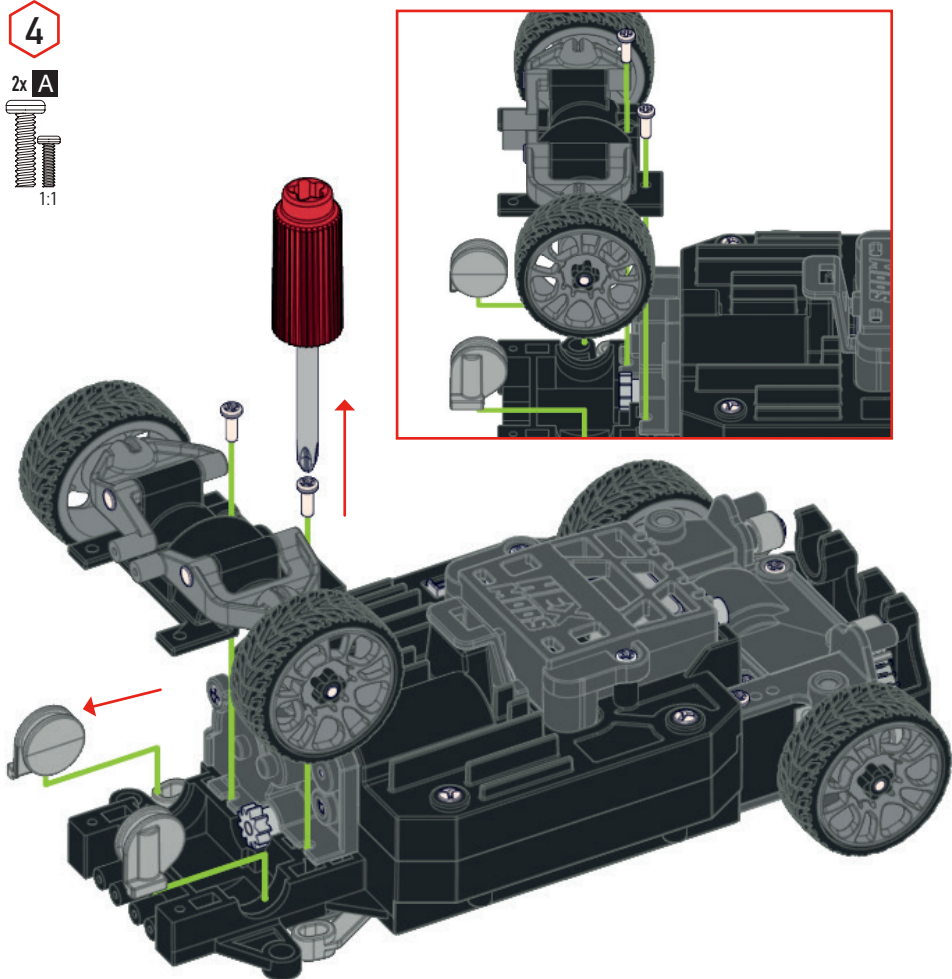

5

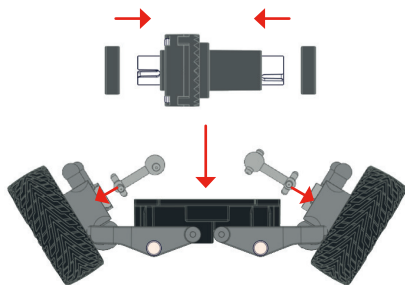
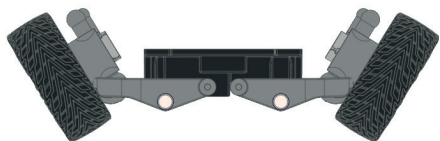

6

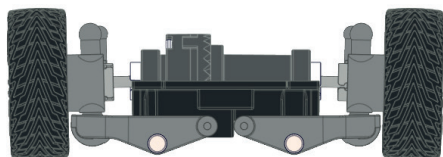
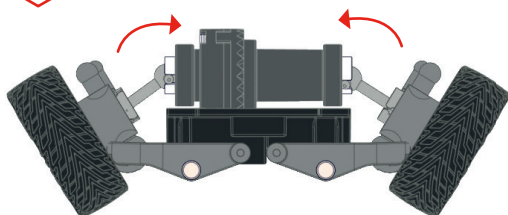

7

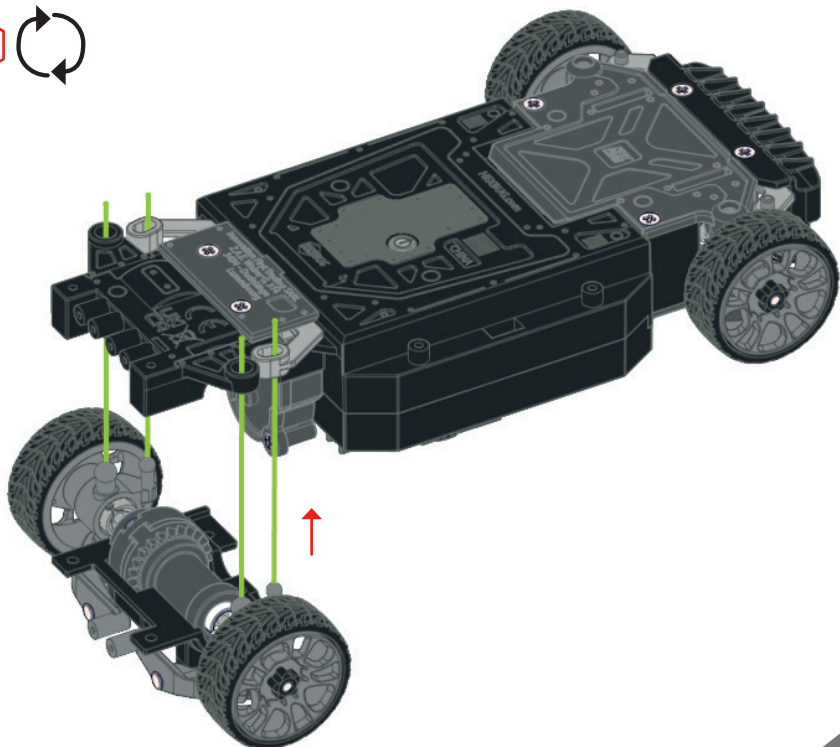

8



2x A

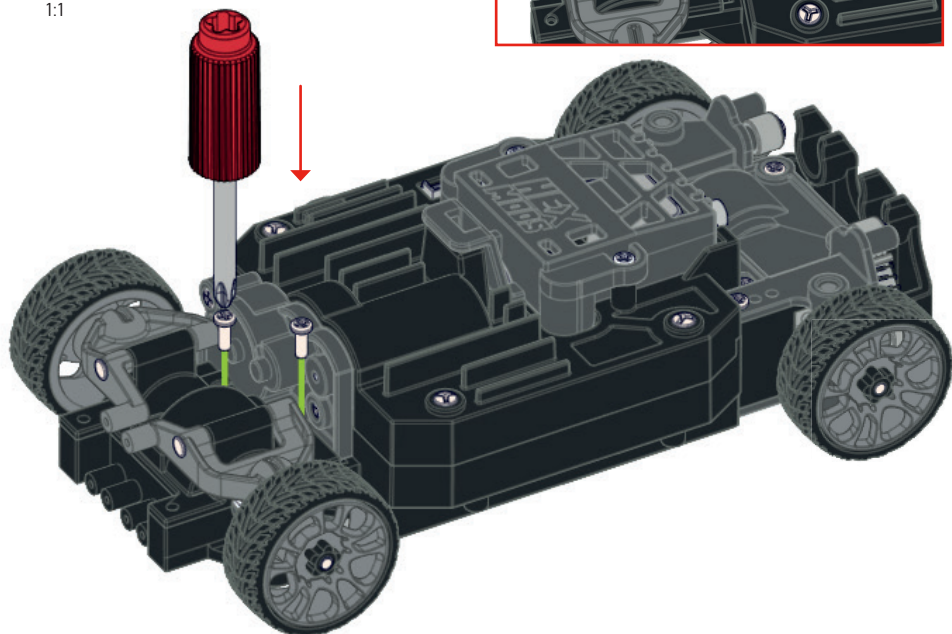

9

4x D

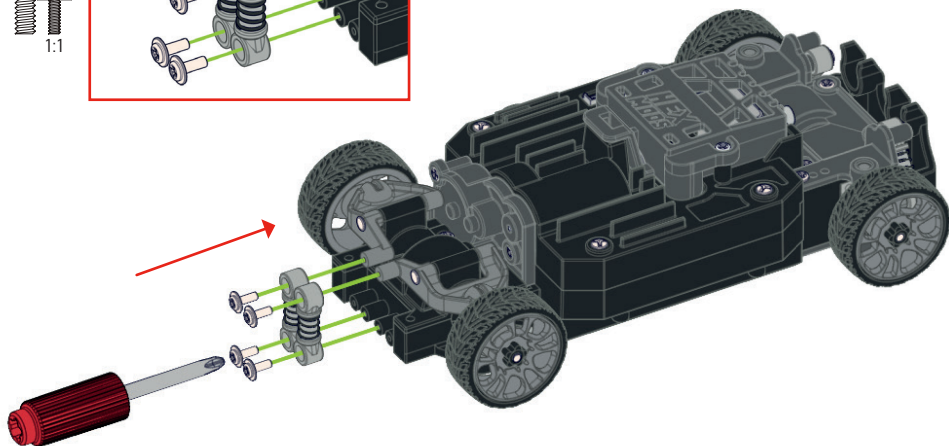
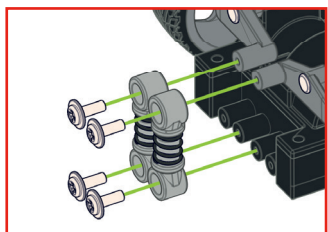

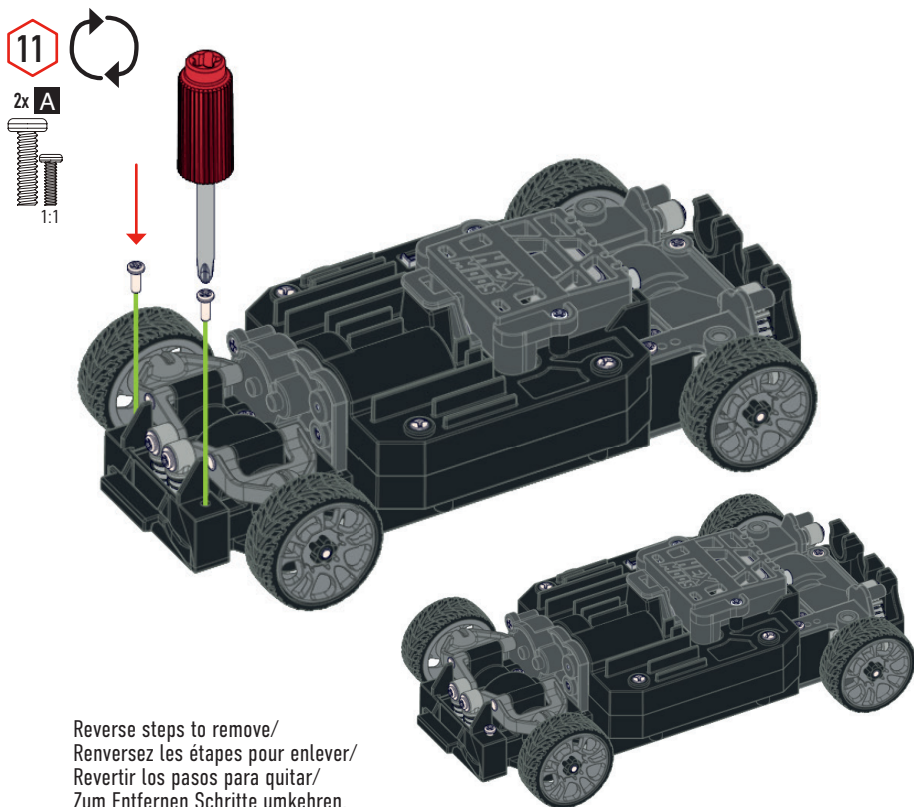
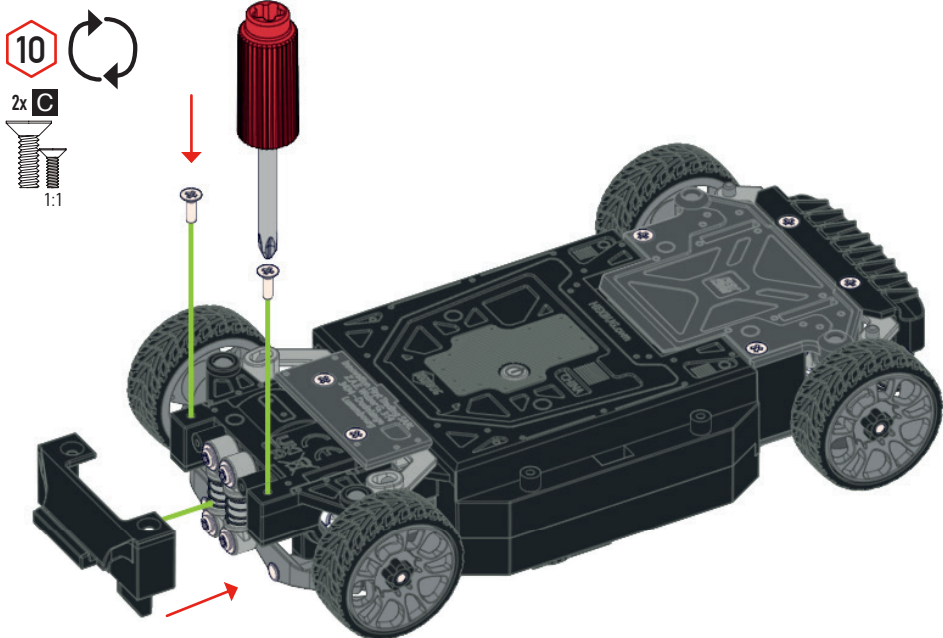

Hexbug® and HEXMODS® are registered trademarks of/ sont des marques de commerce de/son marcas comerciales de/ ist ein eingetragenes Warenzeichen von/ è un marchio registrato di Innovation First, Inc./ The item inside this package may vary from the photographs and /or illustrations. Please retain package for future reference. Please remove all packaging material before giving to children. This product conforms to the safety regulations. Made and assembled in China.Do not put toy in mouth./ L'objet dans cet emballage peut différer des photographies et/ou des illustrations. Veuillez conserver cet emballage pour consultation ultérieure. Enlevez tout l'emballage avant de donner le jouet à des enfants. Ce produit est conforme aux normes de sécurité. Fabriqué et assemblé en Chine. Ne pas mettre le jouet dans la bouche./ El artículo dentro de este empaque puede variar de las fotografías y/o ilustraciones. Conserve este empaque para futuras referencias. Retire todo el material de empaque antes de dar el juguete a los niños. Este producto cumple con las normas de seguridad. Fabricado y ensamblado en China. No se ponga el juguete en la boca./ Der in dieser Verpackung enthaltene Artikel kann von den Fotos und/oder Abbildungen abweichen. Bitte bewahren sie die Verpackung auf, damit sie später ggf. auf diese Information zurückgreifen können. Entfernen sie sämtliche Verpackungsmaterialien, ehe sie das Spielzeug einem Kind aushändigen. Dieses Produkt entspricht den Sicherheitsbestimmungen. Hergestellt und zusammengebaut in China. Das Spielzeug nicht in den Mund stecken./ L'articolo all'interno della confezione può non essere identico alle fotografie e/o illustrazioni. Conservare la confezione per riferimento futuro. Rimuovere tutti i materiali da imballaggio prima di consegnare a bambini. Questo prodotto è conforme alle norme di sicurezza./ Non mettere il giocattolo in bocca./ Copyright © 2022 Innovation First, Inc. All rights reserved/ Tous droits réservés./ Todos los derechos reservados./ Alle Rechte vorbehalten./ Tutti i diritti riservati. Custom manufactured in / Fabriqué sur mesure en / Fabricado a medida en / Hergeesteld in / Prodotto in / Op maat gefabriceerd in / Fabricado a medida na / China For Innovation First Trading SARL. Distributed in the U.S.A. by / Distribué aux Etats-Unis par / Distribuido en los E. Uu. por / Vertriebt in den USA durch / Distribuito negli U.S.A. da / Gedistribueerd in de VS door / Distribuído nos EUA pela / Innovation First Labs, Inc. 6725 W. FM 1570, Greenville, Texas 75402, U.S.A. Distributed in Europe by / Distribué en Europe par / Distribuido en Europa por / Vertriebt in Europa durch / Distribuido en Europa pela / Innovation First Trading SARL, Z.A.E. Wolsker G, 315, 3434 - Dudelange, Luxembourg+352 78 06 47. Distributed in UK by / Distribúe en UK par / Distribuido en UK por / Vertriebt in UK durch / Distribuito in UK da / Gedistribueerd in UK door / Distribuido na UK pela / Innovation First International (UK) Limited, 6 Mellor Court, Hardwick Green, Warrington WA1 4RZ, United Kingdom +44 (0) 1925-453144. DISTRIBUTED IN CANADA BY / DISTRIBUÉ AU CANADA PAR / DISTRIBUÍDO EN CANADÁ POR / VERTRIEBT IN CANADA DURCH / DISTRIBUTO IN CANADA DA / GEDISTRIBUEERD IN CANADA DOOR / DISTRIBUÍDO NO CANADÁ PELA / INNOVATION FIRST TRADING, INC., 6725 W. FM 1570, GREENVILLE, TEXAS 75402, U.S.A. [www.hexbug.com/contact](http://www.hexbug.com/contact) **FCC Note** "This equipment has been tested and found to comply with the limits for a Class B digital device, pursuant to part 15 of the FCC rules. These limits are designed to provide reasonable protection against harmful interference in a residential installation. This equipment generates, uses and can radiate radio frequency energy and, if not installed and used in accordance with the instructions, may cause harmful interference to radio communications. However, there is no guarantee that interference will not occur in a particular installation. If this equipment does cause harmful interference to radio or television reception, which can be determined by turning the equipment off and on, the user is encouraged to try to correct the interference by one or more of the following measures: - Reorient or relocate the receiving antenna. - Increase the separation between the equipment and receiver. - Connect the equipment into an outlet on a circuit different from that to which the receiver is connected. - Consult the dealer or an experienced radio/TV technician for help. **Warning:** Changes or modifications to this unit not expressly approved by the party responsible for compliance could void the user's authority to operate the equipment. **Mention de la FCC** "Ce équipement a été testé et approuvé pour respecter les limites de la Classe B d'appareil numériques, conformément à l'article 15 des règles de la FCC. Ces limites sont conçues pour assurer une protection raisonnable contre l'interférence nuisible dans une installation résidentielle. Cet équipement produit, utilise et émet l'énergie de fréquence radio, et, s'il n'est pas installé et utilisé conformément aux instructions, il peut causer une interférence nuisible aux communications radio. Cependant, il n'y a aucune garantie qu'une interférence n'arrivera pas dans une installation particulière. Si cet équipement cause une interférence nuisible, à la réception de la radio ou de la télévision, qui peut être déterminée par la mise en marche et l'arrêt de l'équipement, l'utilisateur est encouragé à essayer de corriger l'interférence par une ou plusieurs des mesures suivantes: - Réorienter ou déplacer l'antenne de réception. - Augmenter la distance entre l'équipement et le récepteur. - Connecter l'équipement à une sortie sur un circuit différent de celui avec lequel le récepteur est connecté. - Consulter le vendeur ou un technicien de radio/TV expérimenté pour de l'aide. **Attention:** Les changements ou modifications effectués sur cette unité non expressément approuvés par le responsable légal de la conformité pourraient annuler l'autorisation donnée à l'utilisateur pour exploiter l'équipement. **Nota de la Comisión Federal de Comunicaciones (CFC)** "Este equipo ha sido probado y cumple con los límites para un dispositivo digital Clase B, de conformidad con la parte 15 de las reglas de la FCC. Estos límites están diseñados para proporcionar una protección razonable contra interferencias negativas en una instalación residencial. Este equipo genera, usa y puede irradiar energía de radiofrecuencia y, si no se instala y usa de acuerdo con las instrucciones, puede causar interferencia negativa a las radiocomunicaciones. Sin embargo, no hay garantías de que no se producirán interferencias en una instalación particular. Si este equipo causa interferencias negativas en la recepción de radio o televisión, lo que puede determinarse al encender y apagar el equipo, se anima al usuario a intentar corregir la interferencia mediante una de las siguientes medidas: - Volver a orientar o ubicar la antena receptora. - Aumentar la separación entre el equipo y el receptor. - Conectar el equipo a una salida de un circuito diferente del circuito al cual está conectado el receptor. - Consultar al proveedor o a un técnico de radio o televisión con experiencia para obtener ayuda. **Advertencia:** realizar cambios o modificaciones a esta unidad que no estén expresamente aprobados por la parte responsable del cumplimiento podría anular el derecho del usuario a operar el equipo. **FCC statement/Communiqué de la FCC/ Declaración de la FCC** "This device complies with Part 15 of the FCC Rules. Operation is subject to the following two conditions: (1) This device may not cause harmful interference, and (2) this device must accept any interference received, including interference that may cause undesired operation." "Ce dispositif respecte l'article 15 des règles de la FCC. L'opération est soumise aux deux conditions suivantes: (1) Ce dispositif ne peut pas causer d'interférence nuisible, et (2) ce dispositif doit accepter n'importe quelle interférence reçue, même celles qui peuvent causer une opération indésirable." "El dispositivo cumple con la Parte 15 de las Reglas de la FCC. El funcionamiento está sujeto a las siguientes dos condiciones: (1) Este dispositivo no debe causar interferencia negativa y (2) este dispositivo debe aceptar cualquier interferencia recibida, que incluye la interferencia que podría causar un funcionamiento no deseado." **CAN ICES-3(B)/NMB-3(B) ICES statement/Comunique de la ICES/ Declaración de Servicio de Evaluación de Credenciales Internacionales (ICES)** This Class B digital apparatus complies with Canadian ICES-003. / Cet appareil numérique de la classe B est conforme à la norme NMB-003 du Canada/ Este aparato digital Clase B cumple con la norma ICES-003 de Canadá. **BATTERY SAFETY INFORMATION:** - 3 x AAA (R03)(included) - Batteries are small objects. - Replacement of batteries must be done by adults. - Follow the polarity (+/-) diagram in the battery compartment. - Promptly remove dead batteries. - Dispose of batteries immediately and properly. - Wear safety glasses when removing used batteries. - DO NOT dispose of batteries in fire, as batteries may explode or leak. - DO NOT mix old and new batteries or types of batteries (i.e. alkaline/standard). - DO NOT recharge non-rechargeable batteries. - DO NOT short-circuit the batteries. - DO NOT heat, dismantle or deform batteries. - Rechargeable batteries are to be removed from the toy before being charged. - Rechargeable batteries are only to be charged under adult supervision. **INFORMACIÓN DE SEGURIDAD DE LAS PILAS:** - 3 x AAA (R03) (que vienen incluidas). - Las pilas son objetos pequeños. - Los adultos deben cambiar las pilas. - Seguir el diagrama de polaridad (+/-) ubicado en el compartimiento de pilas. - Quitar de inmediato las pilas descargadas. - Deseche las baterías usadas de inmediato y de manera correcta. - Use gafas de seguridad al quitar baterías usadas. - No desechar las pilas en el fuego, ya que pueden explotar o gotear. - No mezclar pilas usadas con nuevas o distintos tipos de pilas (es decir, alcalinas/estándar). - No recargar pilas no recargables. - No colocar las pilas en posición de cortocircuito. - Baterías recargables son de ser quitadas del juguete antes de ser cargadas. - Baterías recargables son de sólo ser cargado bajo supervisión adulta. **CONSIGNS DE SÉCURITÉ CONCERNANT LES PILLES:** - 3 x AAA (R03) (incluse). - Les piles sont de petits objets. - Le remplacement des piles doit se faire par des adultes. - Suivez le schéma qui indique la polarité (+/-) situé dans le compartiment de la pile. - Ne tardez pas à retirer les piles usées. - Jetez immédiatement et de façon appropriée les batteries usagées. - Portez des lunettes de sécurité lorsque vous retirez des batteries usagées. - NE PAS jeter les piles au feu car elles peuvent exploser ou fuir. - NE PAS mélanger des piles usées avec des piles neuves, ou différents types de piles (par exemple, alcalines/standard). - NE PAS recharger des piles non rechargeable. - NE PAS court-circuiter les piles. - NE PAS chauffer, démonter ou déformer les piles. - Les piles rechargeables sont étiquetées du jouet avant d'être chargées. - Les piles rechargeables sont seulement être chargées sous le contrôle adulte. **SICHERHEITSMFORMATIONEN FÜR BATTERIEN:** - 3 x AAA (R03) Batterien (beiliegend). - Batterien sind kleine Gegenstände. - Batterien dürfen nur von Erwachsenen ausgetauscht werden. - Beachten Sie das Polaritätsdiagramm (+/-) im Batteriefach. - Tauschen Sie leere Batterien sofort aus. - Gebrauchte Batterien müssen umgehend und ordnungsgemäß entsorgt werden. - Beim Entfernen von gebrauchten Batterien muss eine Schutzbrille getragen werden. - Entsorgen Sie Batterien NIEMALS in einem Feuer. Batterien können explodieren oder lecken. - Vermischen Sie KEINE alten und neuen Batterien oder unterschiedliche Batterietypen (z.B. Alkali/Normalen). - Laden Sie nicht-aufadbare Batterien NIEMALS auf. - Schließen Sie die Batterien NIEMALS kurz. - Aufadbare Batterien sind aus dem Spielzeug zu entfernen, bevor sie geladen werden. - Aufadbare Batterien dürfen nur unter Aufsicht Erwachsener geladen werden. **INFORMAZIONI DI SICUREZZA SULLE BATTERIE:** - 3 x AAA (R03) (incluse). Le batterie sono oggetti piccoli. - La sostituzione delle batterie deve essere effettuata dagli adulti. - Seguire il diagramma della polarità (+/-) nell'alloggiamento batteria. - Rimuovere tempestivamente le batterie esaurite. - Smettere le batterie immediatamente e in modo appropriato. - Indossare occhiali di sicurezza durante lo smaltimento delle batterie. - Non gettare le batterie nel fuoco in quanto potrebbero esplodere o perdere liquido. - Non mescolare batterie vecchie e nuove o tipi diversi di batterie (es. alcaline/standard). - Non ricaricare batterie non ricaricabili. - Non mettere le batterie in corto circuito. - Le batterie ricaricabili devono essere tolte dal gioco prima di essere addobbate. - Le batterie ricaricabili sono solo essere addobbate sotto la supervisione adulta. **LITHIUM BATTERY SAFETY INFORMATION:** - Dispose of the product properly. - Do not use, leave or store the product close to any heat source or at very high temperatures (for example, in strong direct sunlight or in a vehicle in extremely hot weather). - Do not heat or set the product on fire. - Do not puncture, cut, beat, throw, drop or chisel the battery. - Do not put the product in water or allow to get wet. - Do not disassemble or refill the product. - Do not connect the cable to any other instrument or device. - Do not try to connect the product to anything other than the cable provided. - Do not short circuit battery terminals together. - If the product gives off an odor, generates heat, or leaks chemicals, immediately remove the product from the charger and stop using it. - Do not touch product leakage. Chemicals inside the product can burn your eyes. DO NOT RUB THEM! Rinse immediately with clean running water and seek medical attention at once. - Do not put battery out of product. - Only charge until lights turn off. **INFORMACIÓN DE SEGURIDAD PARA BATERÍAS DE LITIO:** - Elimine el producto de manera adecuada. - No use, deje o almacene el producto cerca de fuentes de calor a temperaturas muy altas (por ejemplo, bajo luz directa del sol o dentro de un vehículo en climas extremadamente calurosos). - No caliente ni prenda fuego el producto. - No perforo, corte, golpee, arroje, tire ni cisele la batería. - No sumerja el producto en agua ni permita que se humedezca. - No desarme ni repare el producto. - No conecte el cable a ningún otro instrumento o dispositivo. - No intente conectar el producto a ningún otro objeto que no sea el cable provisto. - No conecte los terminales de la batería entre sí, ya que provocará un cortocircuito. - Si el producto emana olor, genera calor o pierde químicos, retire el producto del cargador de inmediato y deje de usarlo. - No toque los derrames del producto. Los químicos que contiene el producto pueden producirle quemaduras en los ojos. ¡NO SE LOS FROTE! Enjuáguelos de inmediato con agua corriente y busque atención médica urgente. - No jale la batería para sacarla del producto. - Cargue solo hasta que las luces se apaguen. **INFORMAZIONI RELATIVE ALLA SICURTÀ DE LA BATTERIA AU LITHIUM.** - Eliminer le produit correctement. - Ne pas utiliser, laisser ou entreposer le produit à proximité d'une source de chaleur ou à des températures très élevées (par exemple, à la lumière directe du soleil ou dans un véhicule par temps extrêmement chaud). - Ne pas chauffer ou enflammer le produit. - Ne pas perforer, couper, battre, jeter, laisser tomber ou ciseler la batterie. - Ne pas mettre le produit dans l'eau et ne pas le mouiller. - Ne pas démonter et remettre le produit en place. - Ne pas connecter le câble à un autre instrument ou périphérique. - Ne pas essayer de connecter le produit à autre chose que le câble fourni. - Ne pas court-circuiter les bornes de la batterie. - Si le produit dégage une odeur, génère de la chaleur ou laisse couler des produits chimiques, retirez immédiatement le produit du chargeur et cessez de l'utiliser. - Ne touchez pas les fuites de produit. Les produits chimiques à l'intérieur du produit peuvent brûler vos yeux. NE LES FROTTEZ PAS ! Rincer immédiatement à l'eau courante et consulter immédiatement un médecin. - Ne sortez pas la batterie du produit. - Chargez seulement jusqu'à ce que les lumières s'éteignent. **SICHERHEITSMFORMATIONEN FÜR LITHIUMBATTERIEN:** Entsorgen Sie das

Produkt ordnungsgemäß. Das Produkt niemals in der Nähe einer Wärmequelle oder bei hohen Temperaturen verwenden oder lagern (z. B. bei starker direkter Sonneneinstrahlung oder in einem Fahrzeug bei extrem heißem Wetter). Das Gerät nicht erhitzen oder in Brand setzen. Die Batterie niemals durchstechen, schneiden, schlagen, werfen, fallenlassen oder aufmeißeln. Das Produkt nicht in Wasser legen und nicht nasch werden lassen. Das Produkt niemals auseinandernehmen und anschließend wieder zusammensetzen. Das Kabel nicht an andere Geräte anschließen. Das Produkt niemals an irgendetwas anderes als das mitgelieferte Kabel anschließen. Batteriepool nicht kurzschließen. Wenn das Produkt einen Geruch abgibt, Hitze erzeugt oder Chemikalien aus ihm entweichen, dann sofort aus dem Ladegerät entfernen und nicht weiter benutzen. Ausflüsse des Produktes nicht berühren. Chemikalien im Inneren des Produktes können bei Augenkontakt zu Verletzungen führen. NICHT REIBEN! Sofort mit sauberem, fließendem Wasser ausspülen und umgehend einen Arzt aufsuchen. Die Batterie nicht aus dem Gerät herausziehen. Nur Aufladen bis das Licht erlischt.

**INFORMAZIONI DI SICUREZZA SULLE BATTERIE AL LITIO:** - Smettere il prodotto in modo appropriato. - Non utilizzare, lasciare o conservare il prodotto vicino a qualsiasi fonte di calore o a temperature molto elevate (ad esempio alla luce del sole diretta o in un veicolo con temperature elevate). - Non riscaldare e non gettare il prodotto nel fuoco. - Non forare, tagliare, sbattere, far cadere o colpire il prodotto con oggetti appuntiti. - Non gettare il prodotto in acqua, né bagnarlo. - Non smontare o disassemblare il prodotto. - Non collegare il cavo a qualsiasi altro strumento o dispositivo. - Non collegare il prodotto utilizzando altro che non sia il cavo fornito. - Non cortocircuitare i terminali della batteria. - Se il prodotto si surriscalda o, genera calore o è fonte di perdite di sostanze, rimuoverlo immediatamente il prodotto dal caricatore e interrompere l'utilizzo. - Non toccare le eventuali perdite del prodotto. Le sostanze chimiche contenute all'interno possono creare ustioni agli occhi. - Non SFREGARSI GLI OCCHI! Risciacquare immediatamente con acqua corrente e rivolgersi ad un medico - Non rimuovere la batteria dal prodotto. - Caricare fino allo spegnimento della spia. This device contains licence-exempt transmitter(s)/receiver(s) that comply with Innovation, Science and Economic Development Canada's licence-exempt RSS(s). Operation is subject to the following two conditions: / L'émetteur/récepteur exempt de licence contenu dans le présent appareil est conforme aux CNR d'Innovation, Sciences et Développement économique Canada applicables aux appareils radio exempts de licence. L'exploitation est autorisée aux deux conditions suivantes :

1. This device may not cause interference./ L'appareil ne doit pas produire de brouillage;
2. This device must accept any interference, including interference that may cause undesired operation of the device/ L'appareil doit accepter tout brouillage radioélectrique subi, même si le brouillage est susceptible d'en compromettre le fonctionnement.

**CAUTION/ ATTENTION/ PRECAUCIÓN :**

- Risk of fire and burns. Do not open, crush, heat above 60°C or incinerate./ Risque d'incendie et de brûlures. Ne pas ouvrir, écraser, chauffer au-dessus de 60 °C ou incinérer./ Riesgo de incendio y quemaduras. No abrir, triturar, calentar a más de 60 °C ni incinerar./ Gefahr von Feuer und Verbrennungen. Nicht öffnen, zerdrücken, über 60°C erhitzen oder verbrennen.
- Do not recharge the battery pack that shows signs of leakage or corrosion./ Ne pas recharger un bloc-piles qui présente des signes de fuite ou de corrosion./ No recargue la batería si muestra signos de fugas o corrosión./ Akku nicht aufladen, wenn er Anzeichen von Auslaufen oder Korrosion aufweist.
- Do not dispose of the battery in fire./ Ne pas jeter les piles au feu./ No arroje la batería al fuego./ Batterie nicht ins Feuer werfen.
- Must be disposed of properly./ Doit être éliminé correctement./ Debe desecharse correctamente./ Ordnungsgemäß entsorgen.
- Do not short-circuit./ Ne pas court-circuiter./ No haga cortocircuito./ Nicht kurzschließen.
- Never charge batteries unattended or without adult supervision./ Ne jamais charger les piles sans surveillance ou sans la surveillance d'un adulte./ Nunca cargue las baterías sin supervisión o sin la supervisión de un adulto./ Batterien niemals unbeaufsichtigt oder ohne Aufsicht von Erwachsenen aufladen.
- Do not heat or set the battery on fire./ Ne pas chauffer et ne pas mettre le feu aux piles./ No caliente ni prenda fuego la batería./ Batterie nicht erhitzen und nicht in Brand setzen.
- Do not disassemble or refill the battery./ Ne pas démonter et ne pas remonter la batterie./ No desmonte ni vuelva a colocar la batería./ Batterie nicht auseinander- und wieder zusammenbauen.
- Use only with USB A-C cable DC 5V Max 2A/ Utiliser uniquement avec un câble USB c.a. 5 V c.c max. 2 A/ Usar solo con cable USB AC DC 5V Máx 2A/ Nur mit USB A-C-Kabel DC 5V verwenden. Max. 2A
- Keep the instructions since it contains important information/ Conservez les instructions car elles contiennent des informations importantes/ Conserve las instrucciones, ya que contienen información importante./ Anleitung aufbewahren, sie enthält wichtige Informationen.
- Charger used with toy should be regularly examined for damage to the cord, plug, enclosure and other parts, and in the event of such damage, it must not be used until the damage has been repaired./ Le chargeur utilisé avec le jouet doit être régulièrement examiné pour détecter tout dommage au cordon, à la prise, au boîtier et à d'autres pièces, ainsi que dans le cas de tels dommages, il ne doit pas être utilisé tant que les dommages n'ont pas été réparés./ El cargador que se usa con un juguete debe examinarse periódicamente para detectar daños en el cable, el enchufe, la carcasa y otras partes, y en caso de que ocurra tal daño, no debe usarse hasta que el daño haya sido reparado./ Das Ladegerät, das mit dem Spielzeug verwendet wird, regelmäßig auf Schäden an Kabel, Stecker, Gehäuse und anderen Teilen untersuchen, bei Beschädigungen darf es nicht verwendet werden, bis der Schaden behoben ist.
- This toy contains batteries that are non-replaceable/ Ce jouet contient des piles non remplaçables/ Este juguete contiene pilas que no son reemplazables/ Dieses Spielzeug enthält Batterien, die nicht austauschbar sind.
- The rechargeable battery is only to be charged by adults or children at least 8 years old/ la pile rechargeable doit être chargée uniquement par des adultes ou des enfants âgés d'au moins 8 ans/ La batería recargable solo debe ser cargada por adultos o niños de al menos 8 años/ Die wiederaufladbare Batterie darf nur von Erwachsenen oder Kindern ab 8 Jahren aufgeladen werden
- This toy is only to be connect to equipment bearing either of the following symbols/ Ce jouet doit être connecté uniquement à un équipement portant l'un des symboles suivants/ Este juguete solo debe conectarse a un equipo que tenga cualquiera de los siguientes símbolos/ Dieses Spielzeug darf nur an Geräte angeschlossen werden, die eines der folgenden Symbole tragen



**WARNING:** Dispose of used batteries immediately. Keep new and used batteries away from children. If you think batteries might have been swallowed or placed inside any part of the body, seek immediate medical attention.



**AVERTISSEMENT:** Éliminez les batteries usagées immédiatement. Gardez les batteries neuves et usagées hors de portée des enfants. Si vous pensez que des batteries ont peut-être été avalées ou introduites à l'intérieur du corps, contactez immédiatement un médecin.



**ADVERTENCIA:** Deseche las pilas usadas de inmediato. Mantenga tanto las pilas nuevas como las usadas fuera del alcance de los niños. Si cree que alguien se ha tragado o insertado una pila en cualquier parte del cuerpo, busque atención médica de inmediato.



**WARNUNG:** Entsorgen Sie Altbatterien unverzüglich. Achten Sie darauf, dass weder neue noch gebrauchte Batterien in die Hände von Kindern geraten. Falls Sie den Verdacht hegen, dass eine Knopfzelle verschluckt oder innerhalb eines Körperteils platziert wurde, suchen Sie unverzüglich einen Arzt auf.



**ATTENZIONE:** Smettere immediatamente le batterie usate. Mantenere le batterie nuove e usate lontane dalla portata dei bambini. Se si ritiene che le batterie siano state ingerite o inserite in qualsiasi parte del corpo, rivolgersi immediatamente a un medico.



**Warning:** CHOKING HAZARD - Small parts, DO NOT put in nose or mouth.  
**Avertissement:** RISQUE D'ASPHYXIE - Ce produit contient de petits éléments, NE PAS mettre dans le nez ou la bouche.  
**Advertencia:** RIESGO DE ASFIXIA - Contiene piezas pequeñas, NO lo meta en la nariz o la boca.  
**Achtung:** ERSTICKUNGSGEFÄHR - Kleinteile, NICHT in die Nase oder den Mund geben.  
**Attenzione:** RISCHIO DI SOFFOCAMENTO - Pezzi piccoli, NON mettere nel naso o nella bocca.



**WARNING:**  
**CHOKING HAZARD**-Small parts.  
 Not for children under 3 years.

**AVERTISSEMENT:**  
**RISQUE D'ÉTOUFFEMENT**- Comporte de petites pièces.  
 Ne convient pas aux enfants de moins de 3 ans.

**ADVERTENCIA:**  
**RIESGO DE ASFIXIA**- Pequeñas partes.  
 No para niños menores de 3 años.

# HEX MODS

RC TUNER CARS

## NIGHT HAWK™



Head to [HEXBUG.com/HEXmodsTips](https://HEXBUG.com/HEXmodsTips) for helpful mod tips.

Naviguez vers [HEXBUG.com/HEXmodsTips](https://HEXBUG.com/HEXmodsTips) pour des astuces de modifications utiles.

Dirígete a [HEXBUG.com/HEXmodsTips](https://HEXBUG.com/HEXmodsTips) para obtener útiles consejos sobre modificaciones.

Besuchen Sie [HEXBUG.com/HEXmodsTips](https://HEXBUG.com/HEXmodsTips) für Modifikationen.



For more options check out the Pro Series Elite™ at your local retailer.

Pour plus d'options, cherchez la Pro Series Elite™ chez votre détaillant local.

Para obtener más opciones, consulte el Pro Series Elite™ en su distribuidor local.

Fragen Sie bei Ihrem örtlichen Händler auch nach dem Pro Series Elite™ Set.